

Topvex FC, CAV conversion (Flow control)



GB Installation instructions

Contents

1 Warnings.....	1
2 Install the pressure transmitter.....	1
3 Wiring	3
4 Configuration (Corrigo).....	4
5 K-factor	5
6 Topvex FC External connections.....	6

1 Warnings

Danger

- Make sure that the Mains supply to the unit is disconnected before performing any maintenance or electrical work!
- All electrical connections must be carried out by an authorized installer and in accordance with local rules and regulations.
- Beware of sharp edges during mounting.

2 Install the pressure transmitter

Remove the supply air fan (figure 1).

Caution

If the unit is already installed in false ceiling, make sure that the fan does not fall down when removing the supply air fan.

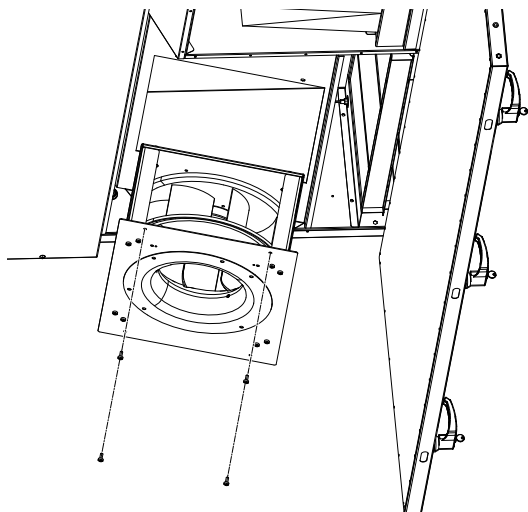

Fig. 1

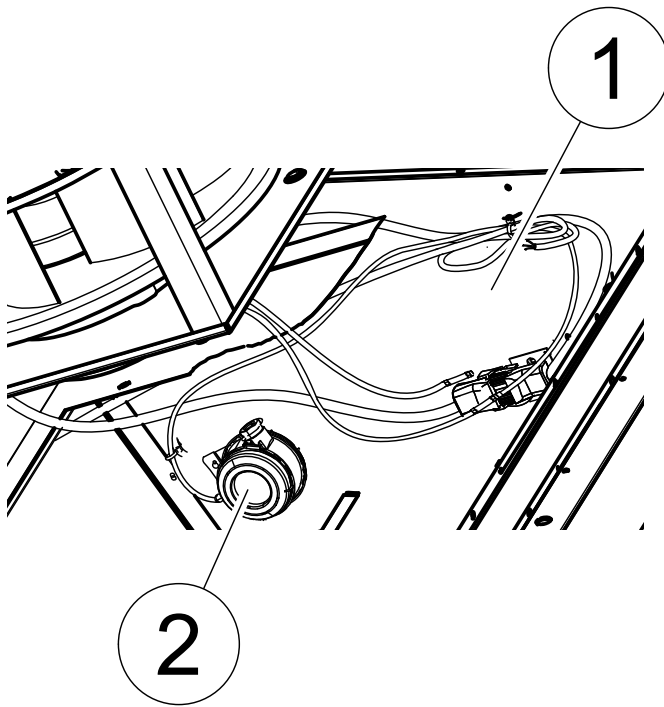
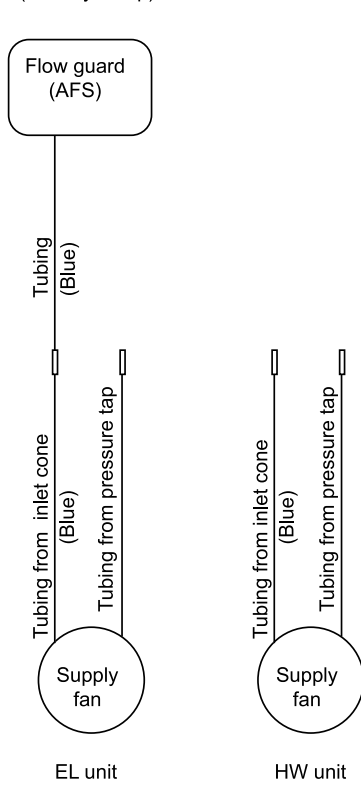

Fig. 2

Mount the enclosed CAV pressure transmitter (PTS) in the pre-punched holes (figure 2, pos 1). Pos 2 only used for units with built-in electrical heater e.g. Topvex FC04 EL.

Standard unit
(Factory setup)



CAV installation

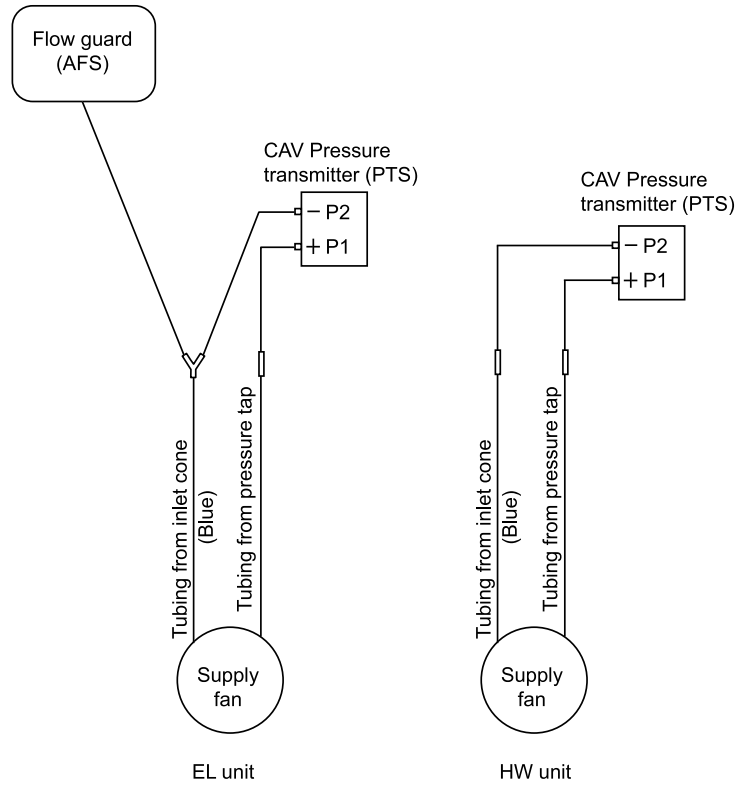

3 Wiring

Convert Topvex FC to a CAV unit by connecting CAV pressure transmitter (PTS) to the pre-wired tubes and electrical cables. For units with electrical heater (EL) the tube from the Flow guard (AFS) to the Supply fan (SF) inlet cone must be cut and connected to the new CAV Pressure transmitter (PTS) by the enclosed Y-connector.

Terminals in the unit are addressed to following terminals in the actual pressure transmitter (see wiring diagram/wiring chart for actual unit).

PTS:

+ = G (Supply voltage 24 V AC)/White wire

0 = 40 (System neutral)/Brown wire

↑ = 42 Output signal 0-10VDC/Green wire

Set the working range for the pressure transmitter.

The working ranges are set by two dip switches on the circuit board in the transmitter (see manual for transmitter).

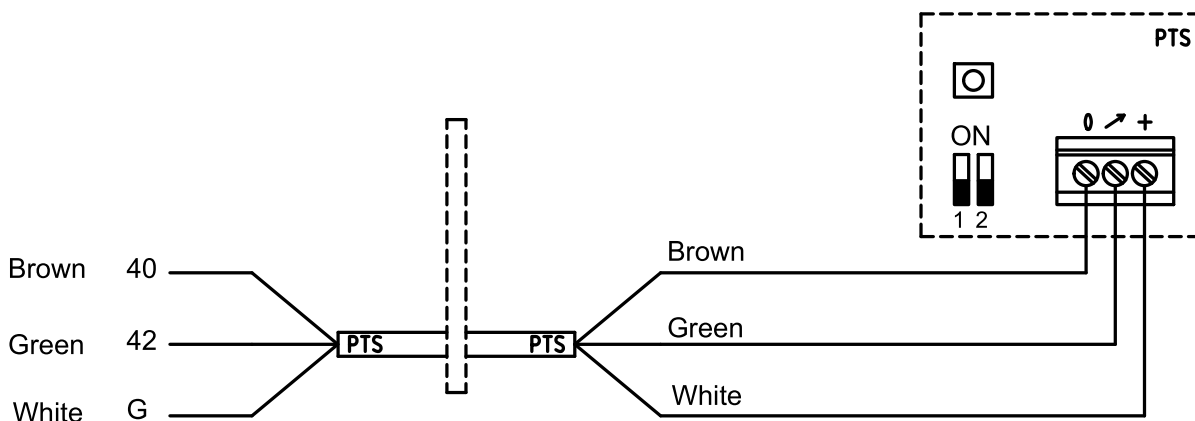

		SW1	SW2	
Topvex FC02	Working range 1	ON	OFF	0...1000 Pa
Topvex FC04	Working range 2	OFF	ON	0...1600 Pa
Topvex FC06	Working range 3	OFF	OFF	0...2500 Pa

4 Configuration (Corrigo)

Log on to Administrator level with password 3333.

Menu level 1	Menu level 2	Menu level 3
Temperature Air control Time settings → Access right	→ Log on Log off Change password	→ Log on Enter password:3333 Actual level:Admin

Inputs/Outputs

Change UAI2 to SAF pressure in Configuration/Inputs/Outputs

Menu level 1	Menu level 2	Menu level 3
Manual auto Settings → Configuration Access right	→ Inputs/Outputs Sensor settings Control function Fan control	AI AI exp3 DI1 → UI

Menu level 4	Menu level 5	
UI1: Choose AI or DI sign AI sign:Not used DI sign:Not used ↓		
UI2:→ Choose AI or DI sign AI sign:Not used DI sign:Not used	UAI2: Sign:SAF pressure Raw value:NaN Compensation: 0.0°C	

Fan control

Set the fan control type in menu Configuration/Fan control.

Set the fan control to Flow control.

Menu level 1	Menu level 2	Menu level 3
Manual/Auto Settings → Configuration Access rights	Sensor settings Control function → Fan control Extra sequence Y4	Fan control Flow control→

Sensor setting.

Set the adjusted working range for the added CAV pressure transmitter in menu Configuration/Sensor setting.

Adjust SAF (supply air fan) and EAF (extract air fan) actual pressure range at 10,0 V.

Example Topvex FC02: If pressure transmitter is set to 0...1000 Pa set: 0,0 V: 0,0 Pa and 10,0 V : 1000,0 Pa. Filter factor is not to be changed.

Menu level 1	Menu level 2	Menu level 3
Manual/Auto Settings → Configuration Access rights	Inputs/Outputs → Sensor settings Control functions Fan control	SAF pressure at 0,0V:0,0 Pa 10,0V:XXX,X Pa Filter factor

Air control setpoint

Adjust the Flow ctrl SAF and Flow ctrl EAF set points.

Menu level 1	Menu level 2	Menu level 3
Running mode Temperature → Air control Time settings	Flow ctrl SAF → Actual:m ³ /h Setp:m ³ /h ↓	Flow ctrl SAF Setp 1/1: 800 m ³ /h Setp 1/2: 400 m ³ /h ←
	Flow ctrl EAF → Actual:m ³ /h Setp:m ³ /h ↓	Flow ctrl EAF Setp 1/1: 800 m ³ /h Setp 1/2: 400 m ³ /h

5 K-factor

	Supply air	Extract air
Topvex FC02	62	55
Topvex FC04	66	72
Topvex FC06	140	131

6 Topvex FC External connections

Table 1: Connections to external functions

Terminal block		Description	Remark
	PE	Ground	
N	N	Earthed neutral (supply voltage)	
L1	L1	Phase (supply voltage)	Used for phase 230V 1~ if the unit has this mains supply 400V 3~
L2	L2	Phase (supply voltage)	400V 3~
L3	L3	Phase (supply voltage)	400V 3~
1	G	Mains supply (Water valve actuator)	24V AC
2	G0	Reference (Water valve actuator mains supply)	24V AC
10	DO ref	DO reference	G (24V AC)
12 ¹	DO 2	Outdoor/Exhaust air damper	24V AC Max. 2,0 A continuous load
WP	L1	Circulation pump hot water system	230V AC
14 ¹	DO 4	Cooling pump	24V AC
15 ¹	DO 5	DX Cooling step 1	24V AC
16 ¹	DO 6	DX Cooling step 2	24V AC
17 ¹	DO 7	Alarm output for DO signals	24V AC
30	AI Ref	Supply air sensor reference	neutral
31	AI 1	Sensor supply air	
40	Agnd	UI reference	neutral
41	UAI 1/(UDI 1)	Not used	
42 ²	UAI 2/(UDI 2)	Pressure transmitter supply air	
44	UAI 3/(UDI 3)	Frost protection sensor water heating battery	Use terminal 40 as reference
4 ³	DI ref	External function reference	+ 24V DC
50/60	B	Exo-line B	Modbus, Exo-line connection
51/61	A	Exo-line A	Modbus, Exo-line connection
52/62	N	Exo-line N	Modbus, Exo-line connection
53/63	E	Exo-line E	Exo-line connection
74 ³	DI 4	Extended running	Normally open contact Use terminal 4 as reference
75 ³	DI 5	Fire alarm	Normally open contact Use terminal 4 as reference

Connections to external functions cont'd

Terminal block		Description	Remark
76 ³	DI 6	External stop	Normally open contact Use terminal 4 as reference
90	Agnd	AO Reference	neutral
93	AO 3	Control signal, Heating	0–10V DC
94	AO 4	Control signal, Cooling	0–10V DC

1. *Maximum current load for all DO combined: 8A*
2. *Connection to internal pressure sensor in case of constant air volume controlled unit (CAV)*
3. *These inputs may only be wired to voltage free contacts*

Systemair AB reserves the right to make changes and improvements to the contents of this manual without prior notice.



Systemair Sverige AB
Industrivägen 3
SE-739 30 Skinnkatteberg, Sweden

Phone +46 222 440 00

Fax +46 222 440 99

www.systemair.com