

RoofLine

Heat recovery ventilation units for roof installation



RoofLine

Roof ventilation units for energy-saving ventilation and heating of halls.

Systemair RoofLine roof ventilation units for peripheral ventilation with heat recovery and heating (version for heating and cooling possible as well) for exposition halls, fair halls, industrial buildings, storage buildings, gyms, multi-purpose buildings, indoor tennis centres, etc. RoofLine units consist of: an outdoor unit with fully insulated, corrosion-resistant casing, low in weight, produced fully from salt-water-resistant aluminium alloy AlMg3, a roof frame, adaptable to the specific installation

situation and roof construction, and an indoor unit for direct air supply and air extraction without ducts, with possibility of installation of water heating coil, water cooling coil or reversible coil (heating / cooling), with special roof air outlet for safe and draft-free air intake even in high buildings with RotaVent (rotating nozzle) or controlled swirl diffuser. Suction part with grilles or air duct connection for the exhaust air suction.

Highlights

- 4 unit sizes with airflow up to 13.000 m³/h
- Equal draft-free air and temperature distribution for room heights up to 30m
- Compact, lightweight sea water resistant (AlMg3) casing
- Aluminium thermal break profiles
- High efficient counterflow plate heat exchanger with heat recovery efficiency up to 90 %
- Energy efficient plug fans with EC motors for quiet and long-life operation
- Integrated control system with master/slave control
- Easy integration of control system into building management system
- Flexible design of indoor part according to customer requirements
- Large inspection doors for easy maintenance
- For building retrofitting and different roof designs
- No duct system necessary
- Combination of units with fresh air and recirculation air
- Sound attenuator for exhaust and supply air optional
- Water heating coil, water cooling coil or reversible coil optional

Winter operation

a) Ventilation with heat recovery

Heat recovery from the extract air to outdoor air (supply air), dampers for outdoor and exhaust air are opened to minimum amount of outdoor (fresh) air, bypass damper is controlled depending on the required supply air temperature for power control of the heat recovery function, temperature control for heat recovery and subsequent heating valve.

b) Heating operation

For quick heating-up of the building, dampers for outdoor and exhaust air are remained closed, except for the minimum amount of fresh air, the recirculating air damper is opened.

Summer operation

a) Ventilation only

Ventilation without heat recovery, dampers for outdoor and exhaust air and the bypass damper are opened, the heating valve is closed.

Components

The unit consists of 3 main parts, an outdoor unit, a roof frame and an indoor unit.

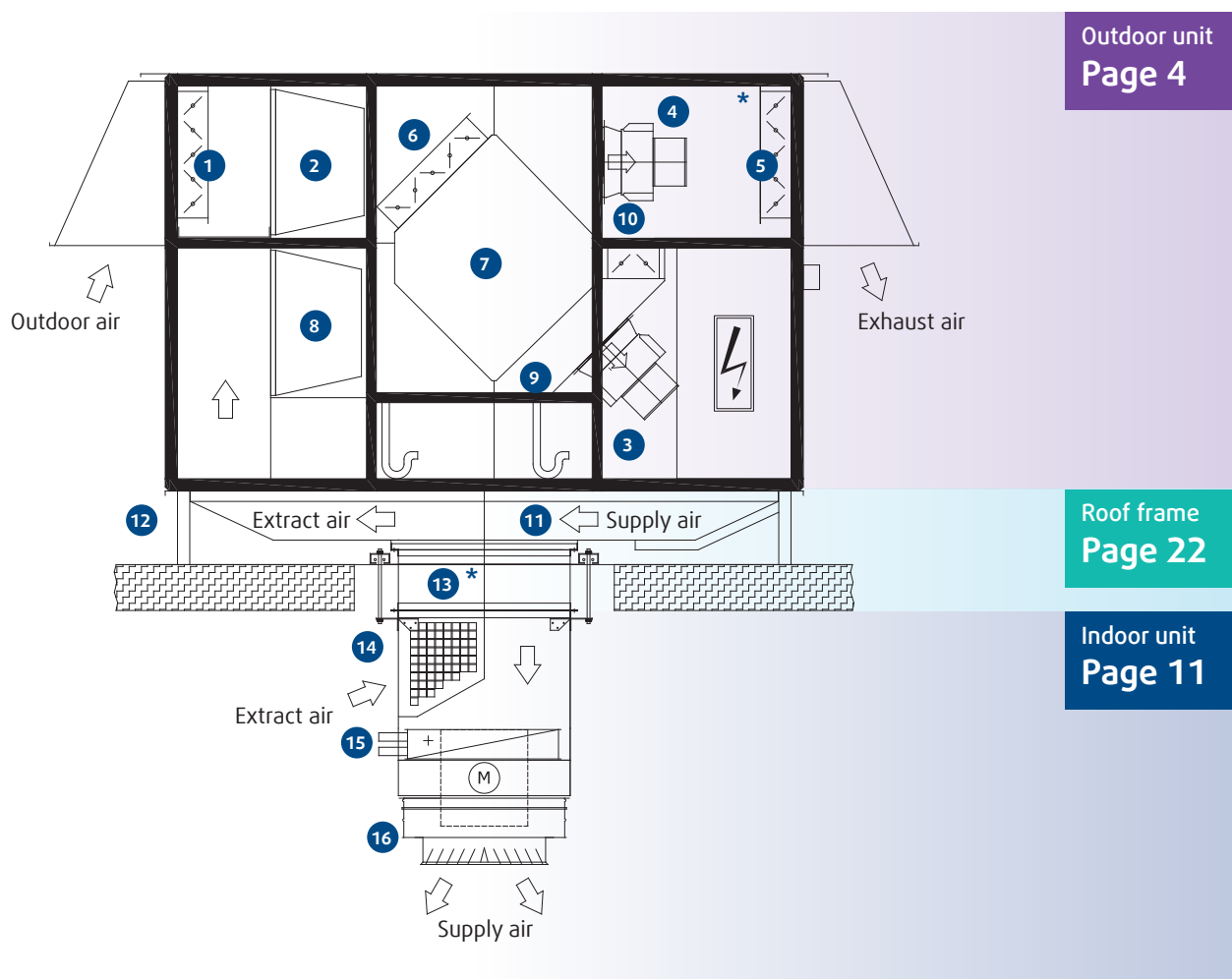

- | | | |
|------------------------------------|--------------------------------|--|
| 1 Outdoor air damper | 8 Extract air filter | 15 Heating coil |
| 2 Outdoor air filter | 9 Siphon | 16 RotaVent (rotating nozzle) or swirl diffuser |
| 3 Supply fan | 10 Recirculating air damper | * Sound attenuator for exhaust and supply air optional |
| 4 Extract fan | 11 Supply and extract air duct | |
| 5 Exhaust air damper | 12 Roof frame | |
| 6 Bypass damper | 13 Transition duct piece | |
| 7 Counterflow plate heat exchanger | 14 Extract air grid | |

Outdoor unit

Weather-proof casing made of corrosion-resistant aluminium alloy AlMg3, double-shell wall panels with intermediate insulation made of non-flammable mineral fibre boards according to DIN 1643 with an insulation thickness of 50 mm.

Revision doors with exterior hinges and handles, with gaskets for reliable sealing even at high wind pressures.

Suction and exhaust openings with driving-rain-proof rain hoods made of aluminium and protective bird screens.

The air heater (air cooler) is installed inside to be protected against frost. No pipes on the roof which are subjected to frost.

The casing of the outdoor unit and the indoor unit can be supplied in RAL colours (additional charge).

Available for units without integrated control for additional charge: lockable repair switch for intake and outlet air fan mounted on the unit, all electrical connections wired on central terminal box.

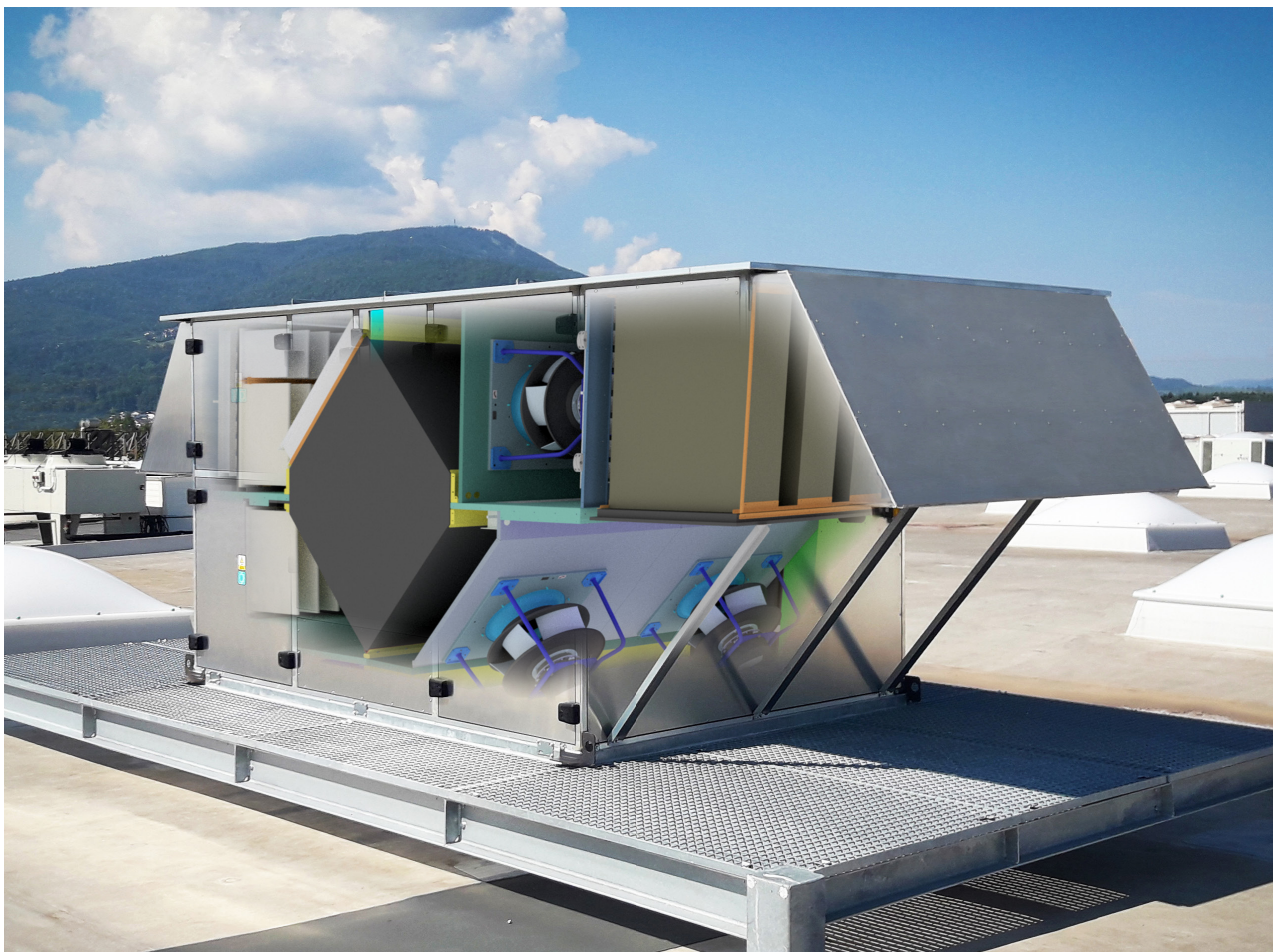

Technical data and dimensions

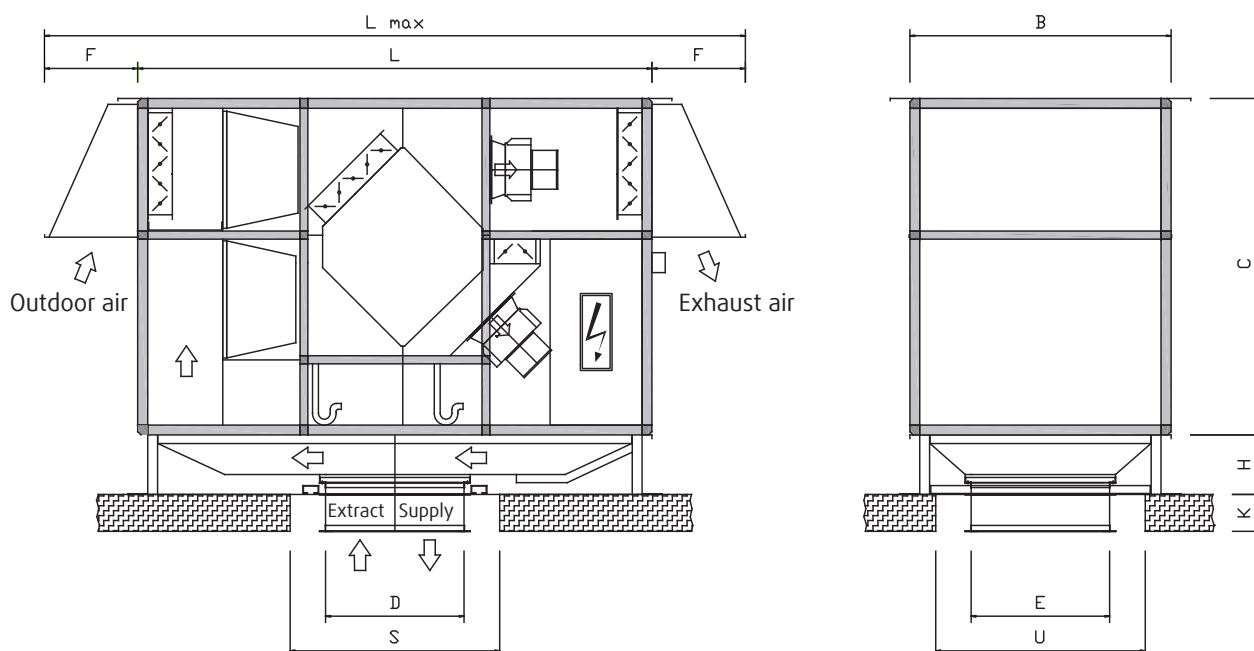

Unit type / size			035	063	080	130
Fans with EC drive						
Nominal air volume		m³/h	3500	6500	8000	12700
Motor power		kW	2 x 1,23	2 x 2,5	4 x 1,10	4 x 1,74
Rated motor current		A	2 x 1,9	2 x 3,8	4 x 1,7	4 x 2,7
Supply voltage		V	400	400	400	400
Heat recovery unit						
	Type		RE81-950	RE95-1250	RE95-1500	RE67-1800C
Length	L	mm	2600	2880	2880	3300
Total length	L max	mm	3540	4120	4120	4940
Width	B	mm	1320	1580	1950	2240
Height	C	mm	1700	1800	1800	2100
	F	mm	470	620	620	820
	D / E	mm	700	1000	1000	1200
Weight without roof frame approx.		kg	525	650	780	990
Height of flat roof frame	H	mm	300	300	300	300
Weight		kg	70	90	105	130
Roof opening	S / U	mm	1060	1360	1360	1560
Roof feed-through	K		Dimensions and weight correspond to the height of the roof construction.			
Outdoor air filter			2x592x592	2x592x592	3x592x592	3x592x592
				1x287x592		4x287x592
						1x287x287
Extract air filter			2x592x592	2x592x592	3x592x592	3x592x592
				1x287x592		1x287x592

Components



Power adjustment

Constant steps or as pressure and flow control by means of an integrated PID controller by a unit controller.



Fans

High performance plug fan with backward curved impeller blades for high efficiency, flow-optimised inflow nozzle, complete unit statically and dynamically balanced according to DIN/ISO 1940 to balance quality G 6.3 on two levels and directly driven by an electronically commutated external rotor motor with integrated power electronics; fault-signal relay with potential-free contacts, locked-rotor protection, phase failure detection, smooth start, undervoltage detection, overtemperature protection for electronics and motor, short-circuit protection. Complete fan unit installed with impeller, motor and inflow nozzle.



Air damper

Air dampers with counter-coupled hollow blades for outdoor air, exhaust air, recirculating air and plate heat exchanger bypass.



Air filter

Outdoor and extract air filters are equipped with high-quality standardised bag filter inserts of filter quality M5 (ePM10 50%), optionally up to F7 (ePM1 60%). The air filters can easily be maintained from the roof.



Sound attenuator

For the operation in very noise-sensitive areas, units with sound absorber at the exhaust air side are available; sound absorbers for supply air incorporated in the transition duct piece are also possible.



Heat recovery

Counterflow plate heat exchanger made of completely smooth, dirt-resistant, crosswise arranged aluminium plates. The heat recovery block can be dismantled for maintenance, two condensate drip trays, safe drainage of condensate through ready-fitted siphons. Integrated bypass for bypassing and power control of the heat recovery unit. Anti-freeze protection and defrost monitoring.



Roof frame

Made of aluminium, consisting of a supporting exterior wall, insulated at the inside with non-flammable mineral fibre boards on all sides, mounting flanges for the fixation of the roof frame to the roof construction and the roof unit. The scope of supply includes roof frame designs for flat roofs, sloped roofs and double sloped roofs, also custom-made to meet constructional requirements.



Control

Continuous room or supply air temperature control, energy optimisation by using the heat generated in the room, mixing air control, air quality controller to optimise the amount of outdoor air, control of the rotating nozzle and/or swirl diffuser depending on the temperature difference between floor and ceiling.

Temperature control

Continuous room temperature control with minimum limitation of the supply air temperature, on the bypass damper of the heat recovery unit to optimise energy and consequently act on the heating valve.

Frost protection monitoring for the continuous frost protection of the hot water reheater and switching on the heating recirculation pump as required. Anti-freeze protection and defrost monitoring for the heat recovery unit.

As soon as the system is turned down and the frost protection reacts, the fans are switched off, the outdoor and exhaust air dampers are closed and the heating valve is opened, as required. Day, night and week program.

Room temperature sensor for averaging, several units within the same temperature range can be combined in a group.

All units can be switched individually.

Operation modes:

Winter mode, ventilation with heat recovery from extract air, filtering and heating of supply air.

The bypass damper of the heat recovery unit is adjusted to control the power of the heat recovery unit depending on the required supply air temperature.

The heating valve is not opened until the heat recovered from the extract air is too low.

Night-time heating reduction and temperature maintenance

Selectable reduction of the room temperature, switchover

by means of the integrated day, night and week program.

Summer mode, ventilation only

Ventilation without heat recovery, the outdoor, exhaust air and bypass dampers are opened, the heating valve is closed.

Return air from under ceiling zone

The roof unit in connection with the Systemair rotating nozzle remains in operation until heat is required. Thus, the heat ascending to the ceiling is continuously returned to the working area.

Fan control

Automatic step circuit to adjust the power of the fans for normal operation and idle operation (night operation).

RotaVent (rotating nozzle) or swirl diffuser

Automatically by the controller depending on the difference between supply air temperature and the temperature in the working area.

Functional diagram

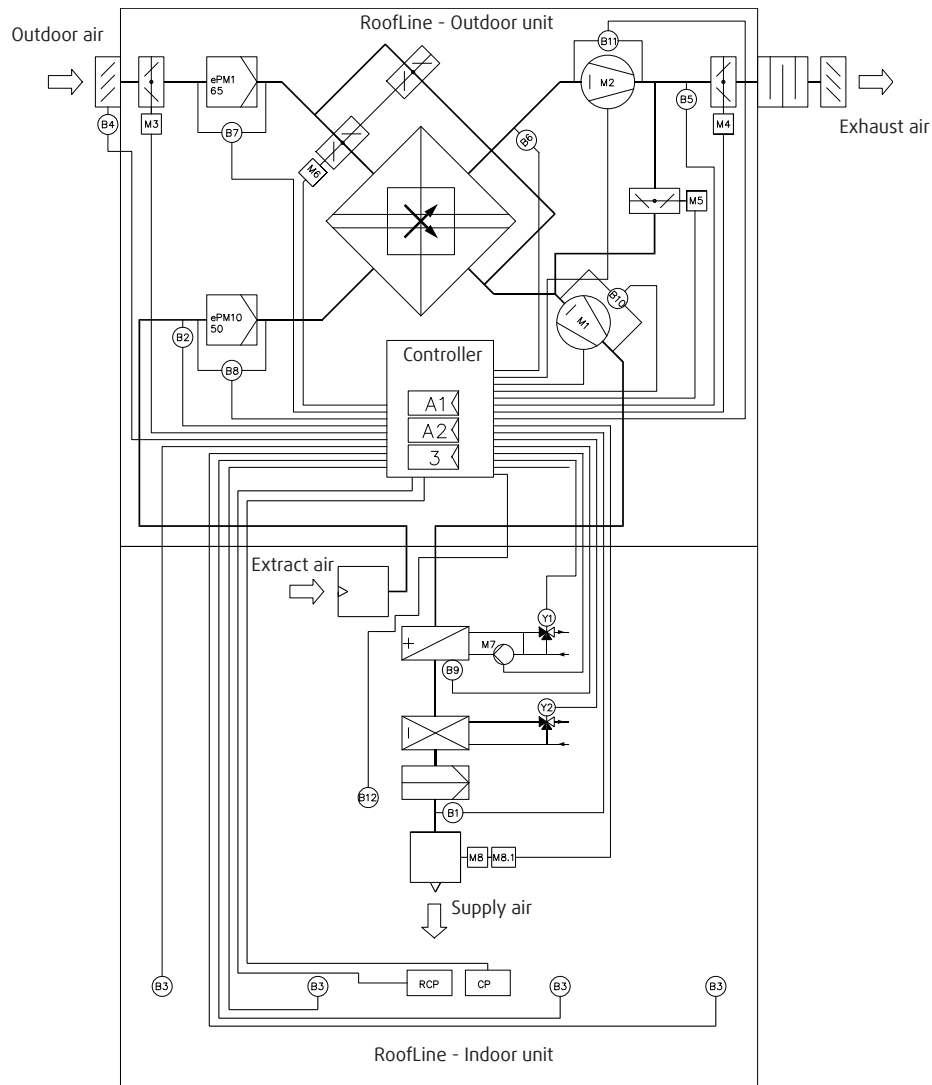

B1	Supply air temperature sensor	Y1	Heating valve
B2	Extract air temperature sensor (optional)	Y2	Cooling valve (optional)
B3	1 or 4 Room temperature sensors	M1	Supply fan
B4	Outdoor air temperature sensor	M2	Extract fan
B5	Exhaust air temperature sensor (optional)	M3	Outdoor air damper actuator
B6	Frost protection sensor	M4	Exhaust air damper actuator
B7	Pressure switch for outdoor air filter	M5	Mixing air damper actuator
B8	Pressure switch for extract air filter	M6	Byypass damper actuator
B9	Frost protection sensor	M7	Secondary pump for water heater
B10	Differential pressure sensor for supply air fan	RCP	Remote control panel
B11	Differential pressure sensor for extract air fan	CP	Remote panel for end user (optional)
B12	CO ² -Sensor (optional)		

airCalc++

Effective and powerful selection tool.

The airCalc++ provides fast selection and thermodynamic calculation of the air handling unit which shall then meet the requirements of the project and the client. By using this application and with regard to the design and the project requirements, we can make a selection as regards the:

- unit type
- unit size
- unit structure with regard to the required functions.

In this way, we acquire a large amount of useful information about the unit – from the technical features of a unit (wattage of components, coefficient of performance, noise, installation dimensions, weight, etc.) to the drawings with all the dimensions in different views



Master-Slave function

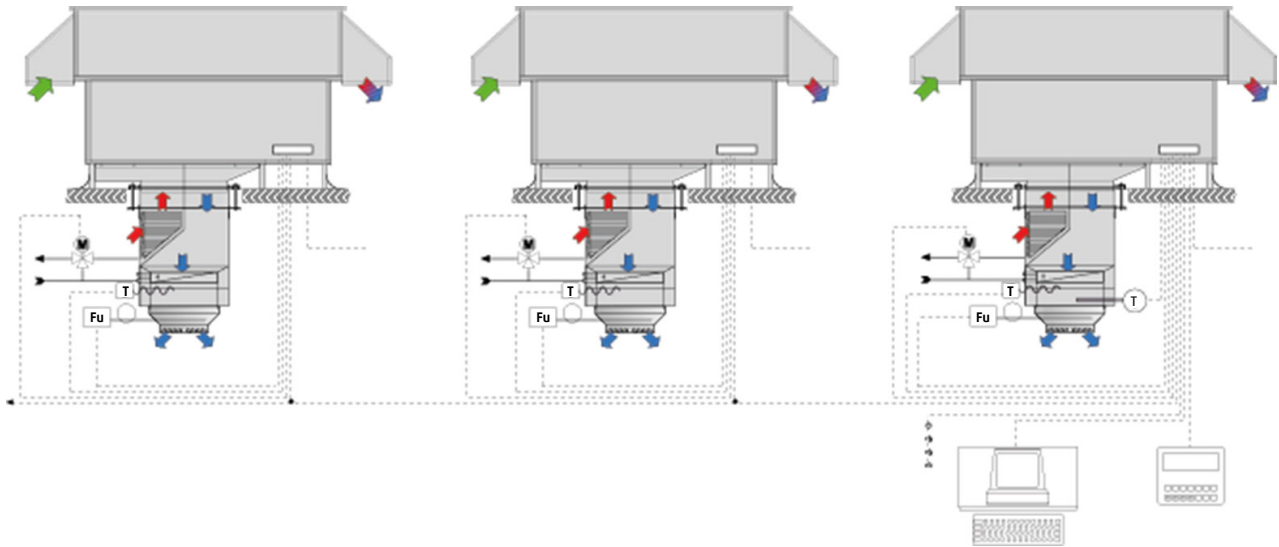

Master unit

The regulation including system controller and all electrical requirements for the operation of the system is integrated and wired in the Systemair RoofLine roof unit. The unit is completely wired; only the supply line, the connection for the heating valve, the recirculation pump and the connection to the pre-wired indoor part must be generated. The control cabinet is located in the ventilation unit thus eliminating the need for extensive and vulnerable cabling between the ventilation unit and the control cabinet. Via the bus included in the system, up to 5 slave units can be connected to one controller. They are controlled via the control terminal, via the PC with visualisation or via the internet.

Slave unit

Slave unit only require power supply, an intake air and frost protection sensor and a connection via the bus to the master unit. The sensor signals for the outside and room temperature are commonly used. A connection between the pre-wired indoor part and the control must be provided on-site. The units are operated parallel to the master and can also be switched individually as an option.

They can also be connected to Bacnet or Modbus as an option.

Indoor unit

Indoor unit for direct supply air penetration and air extraction, self-supporting casing with incorporated air heater (air cooler), standard design with inner core tubes made of seamless copper pipes, aluminium fins

and galvanized steel frames (other designs on request), intake air distribution element (RotaVent - rotating nozzle and/or swirl diffuser), extract air grille or design for duct connection.

Indoor unit with RotaVent

For buildings with a height (blow-off height) of approx. 4.5m up to approx. 30m for the safe, draft-free and large-scale supply of air. With controllable rotating nozzle, individually adjustable air deflection blades, for rotating and fan-shaped air outlet to continuously blend the air in the building and to avoid dead spots between shelves and machines.

Decreases the temperature gradient between floor and ceiling by 0.3 to

0.5 degrees per metre of altitude. By modifying the rotating nozzle speed by approx. ½ to 5 rotations per minute, a constant air speed of below 0.5m/s at an excess temperature of the intake air of approx. 1.5 to 2 °C above room temperature level in the working area (approx. 1.5m above the floor) is maintained and draft is thus avoided.

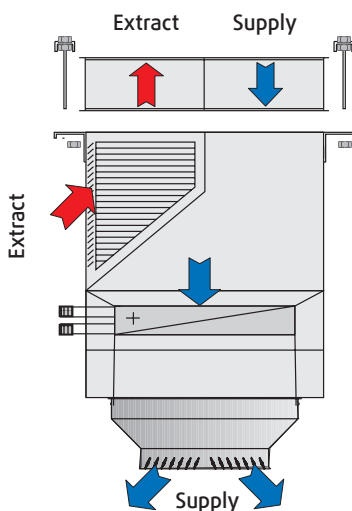
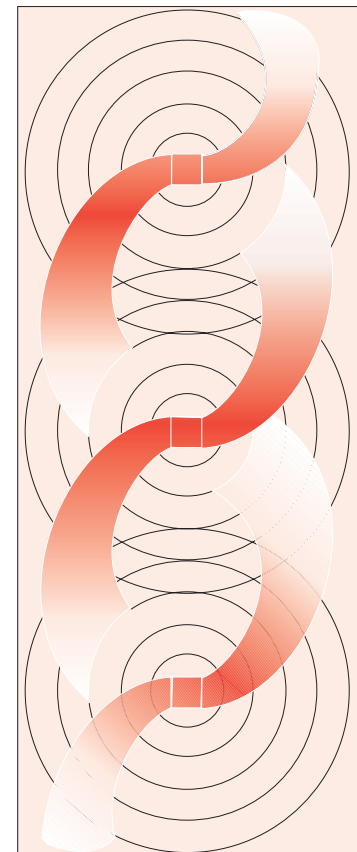
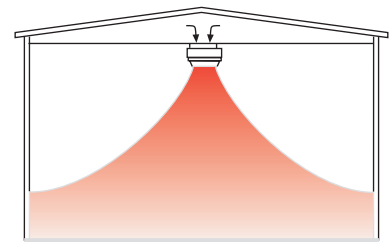

Indoor unit with RotaVent



Air distribution with RotaVent

Airflow profile - RotaVent

Differential temperature control

The changing supply air temperature which is required due to interior and exterior loads imposes high demands on the air outlets due to its changing density and thus its thermal energy (air buoyancy) in order to supply intake air into the working area without drafts and on an optimal energy frame.

Therefore, the speed of the rotating nozzle and/or the cylinder of the variable swirl diffuser must be adjustable, both depending on the temperature difference between room and intake air temperature.

If the room temperature is lower than the supply air temperature, the system is in heating mode. To supply the heat to the room with utmost efficiency, it must be supplied at large scale close to the floor with a highest possible share of inductance. The counter-acting thermal buoyancy must be overcome in this process.

If the room temperature is higher than the supply air temperature, the system is in cooling mode. To avoid the draft, cold supply air is evenly distributed under the ceiling from where it evenly drops down into the room.

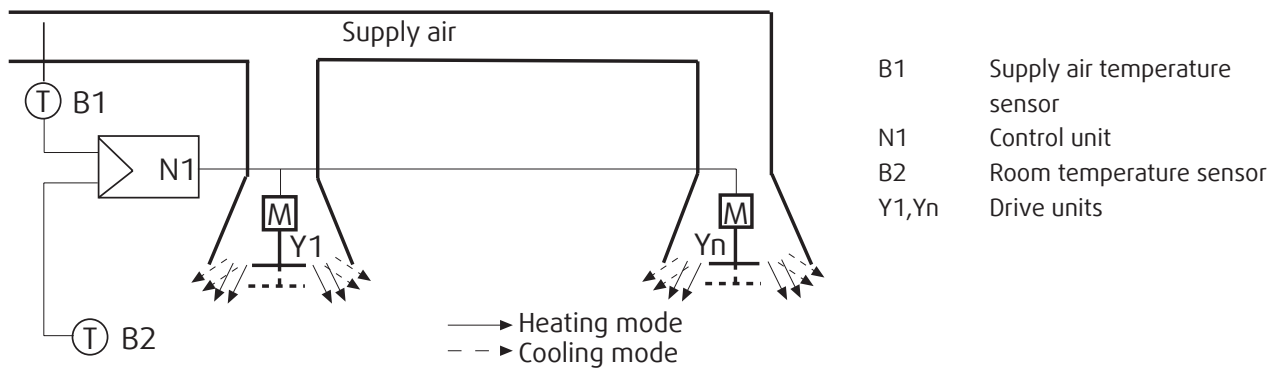

Variable swirl diffuser with cylinder

Cylinder extended	heating mode
Cylinder retracted	cooling mode

Air throw profile

RotaVent

- W_H Horizontal width of the beam axis at the lowest point
- W_G Maximum width of the beam axis
- h Lowest point of the beam axis
- H Installation height
- x Calculated distance from the lowest point of the beam axis to the head height
- α Blow-off angle of the rotating nozzle

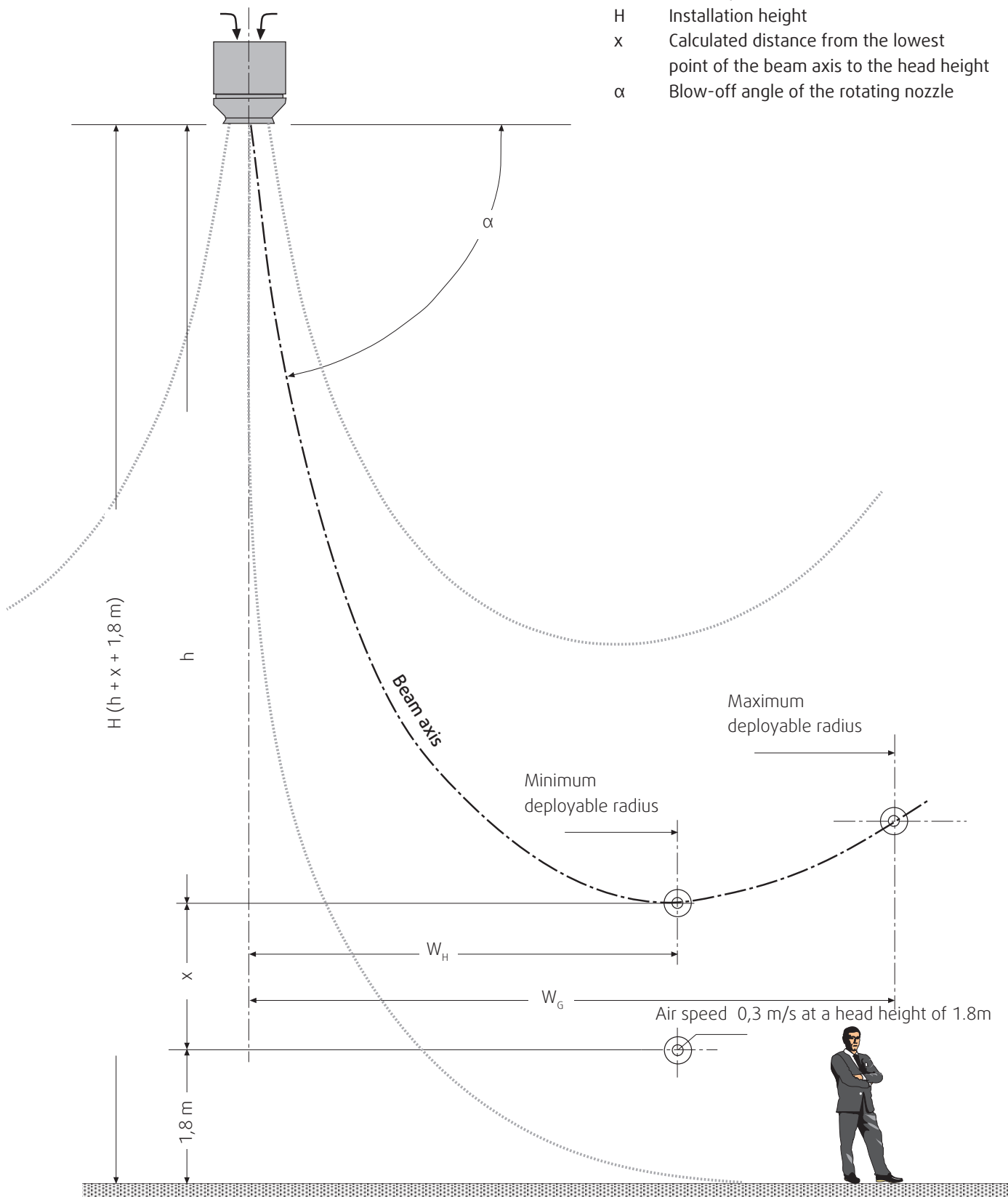

RoofLine unit size 035 with RotaVent (room temperature +18°C)

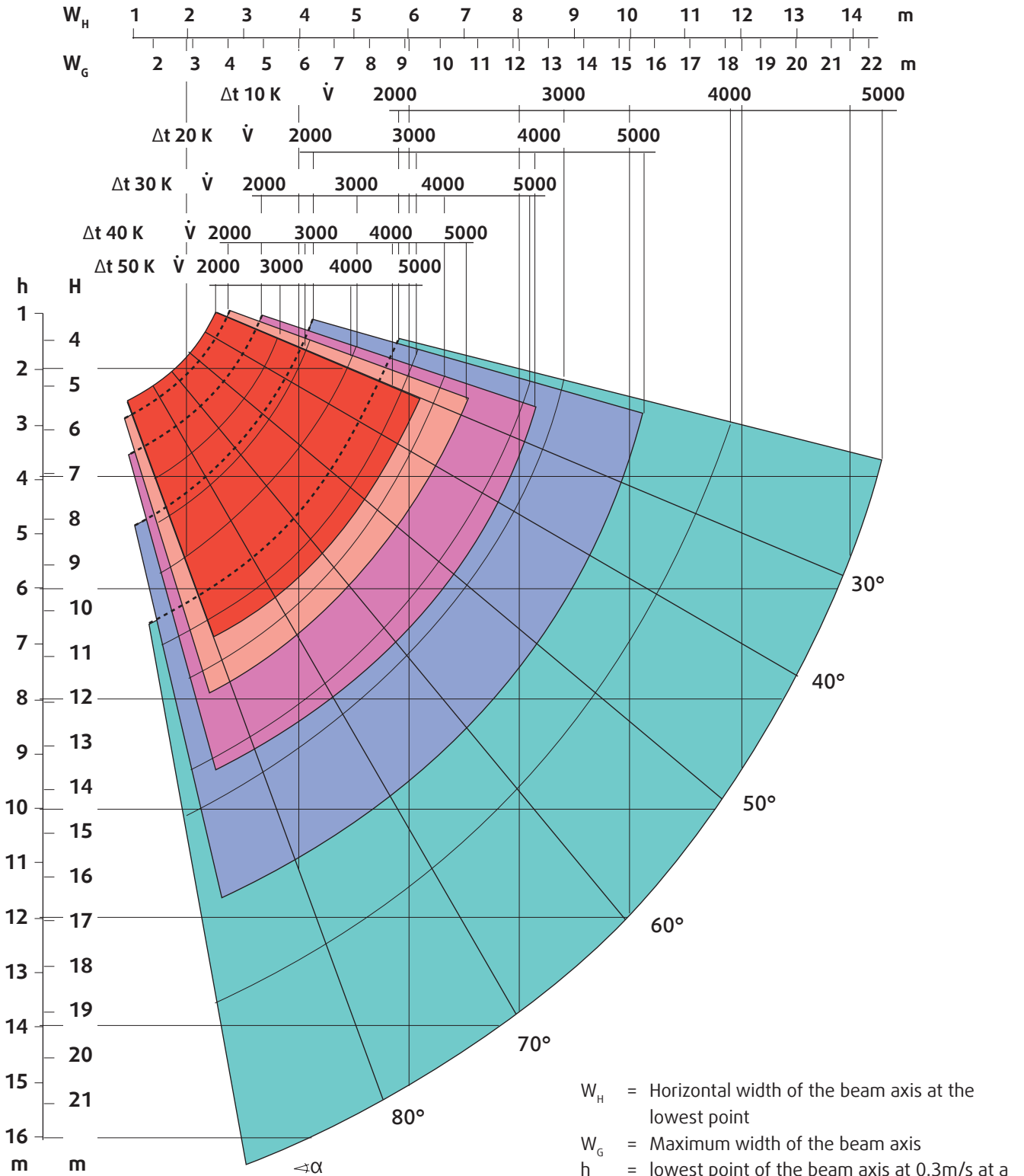

By changing the setting of the air deflection blades of the RotaVent (rotating nozzle) (adjustment of the blow-off angle α), the primary beam length and/or the indentation depth of the air beam (H) is decreased and the spread width of the air beam (WG) is increased.

- W_H = Horizontal width of the beam axis at the lowest point
- W_G = Maximum width of the beam axis
- h = lowest point of the beam axis at 0.3m/s at a height of 1.8m
- H = Installation height to the bottom edge of rotating nozzle
- α = Blow-off angle of the rotating nozzle
- Δt = Temperature difference between air outlet temperature and room temperature ($T_A - t_i$)
- V = Air volume flow [m^3/h]

RoofLine unit size 063 and 080 with RotaVent (room temperature +18°C)

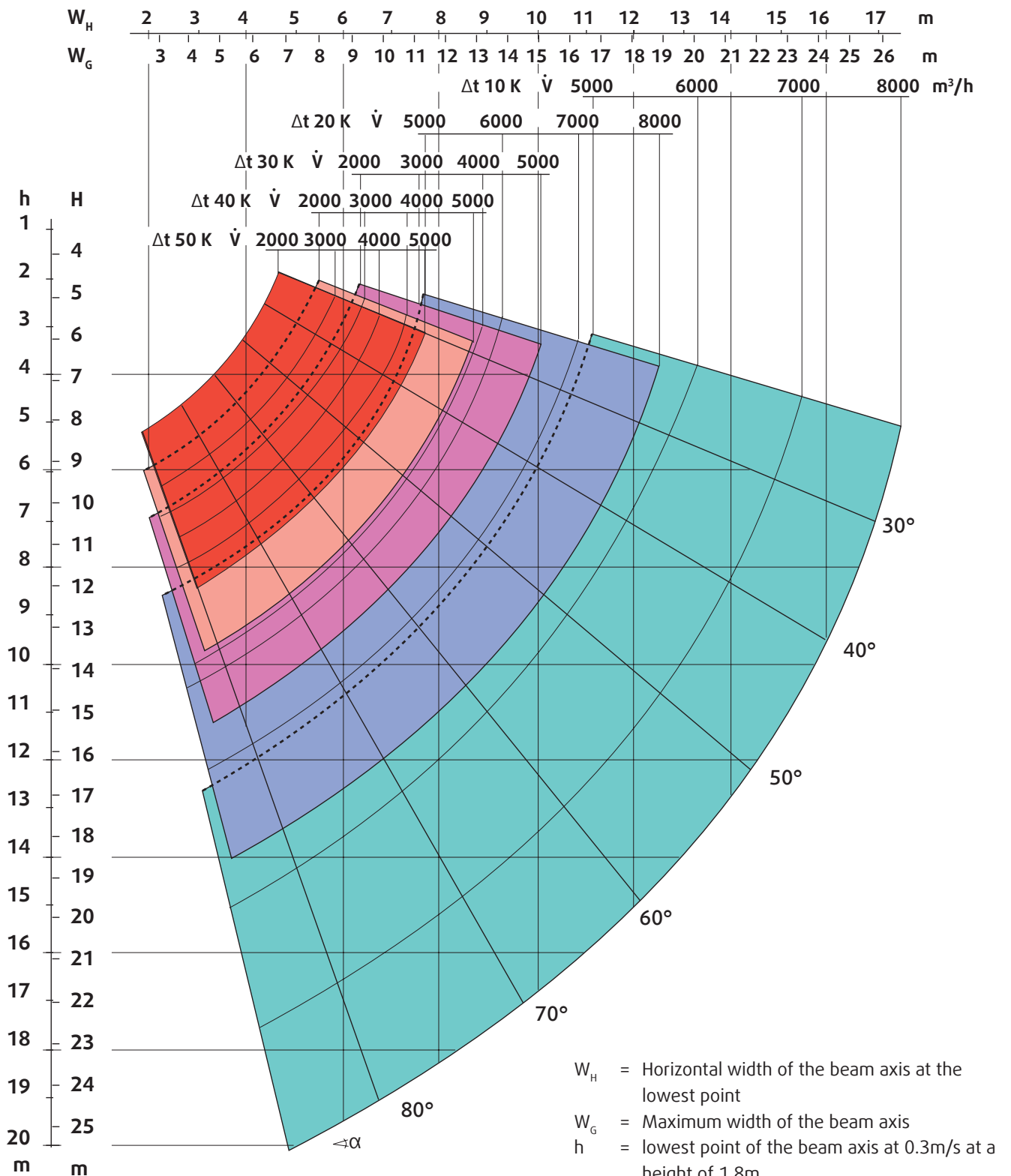

By changing the setting of the air deflection blades of the RotaVent (rotating nozzle) (adjustment of the blow-off angle α), the primary beam length and/or the indentation depth of the air beam (H) is decreased and the spread width of the air beam (WG) is increased.

- W_H = Horizontal width of the beam axis at the lowest point
- W_G = Maximum width of the beam axis
- h = lowest point of the beam axis at 0.3m/s at a height of 1.8m
- H = Installation height to the bottom edge of rotating nozzle
- α = Blow-off angle of the rotating nozzle
- Δt = Temperature difference between air outlet temperature and room temperature ($T_A - t_i$)
- V = Air volume flow [m^3/h]

RoofLine unit size 130 with RotaVent (room temperature +18°C)

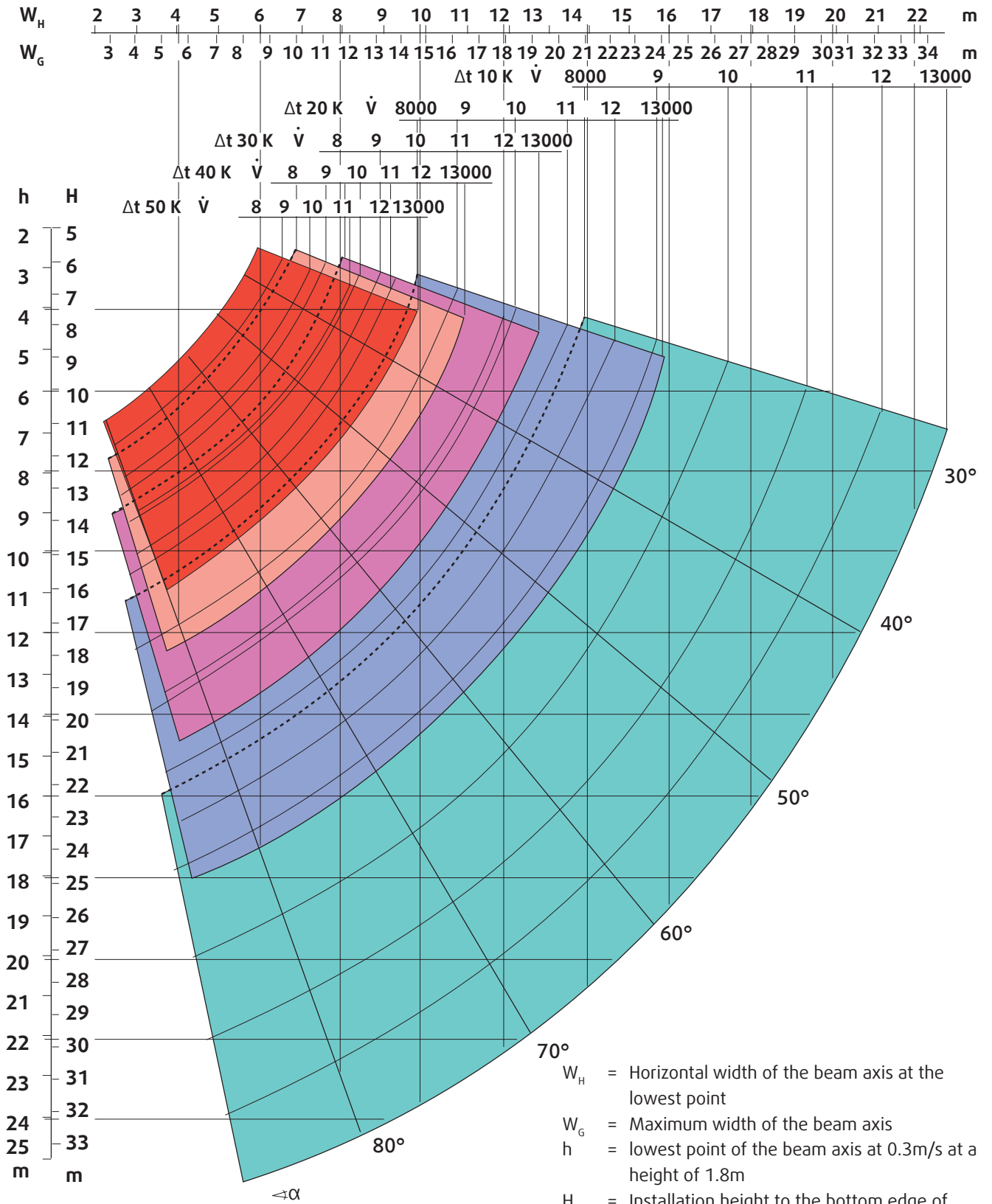

By changing the setting of the air deflection blades of the RotaVent (rotating nozzle) (adjustment of the blow-off angle α), the primary beam length and/or the indentation depth of the air beam (H) is decreased and the spread width of the air beam (WG) is increased.

- W_H = Horizontal width of the beam axis at the lowest point
- W_G = Maximum width of the beam axis
- h = lowest point of the beam axis at 0.3m/s at a height of 1.8m
- H = Installation height to the bottom edge of rotating nozzle
- α = Blow-off angle of the rotating nozzle
- Δt = Temperature difference between air outlet temperature and room temperature ($T_A - t_r$)
- \dot{V} = Air volume flow [m³/h]

Indoor unit with swirl diffuser

Variable swirl diffuser for air volumes of up to 11,000 m³/h and building heights (blow-off height) from 3.5 m to approx. 14.0 m. The swirl diffuser consists of a round exterior cylinder with nozzle-shaped blow-off ring, a movable diffuser cylinder, the core chamber and the immobile diffuser element incorporated in-between. By moving the diffuser cylinder, the blow-off direction of the air beams is continuously changed downwards between horizontal and vertical.

The air beams generated in this process cause the high blending with ambient air and thus a quick adjustment to the room air temperature.

Once the diffuser cylinder is completely retracted, the escaping air beams cling to the round outlet generating a

radial horizontal beam deflection.

This allows for the use in rooms with low blow-off height or for high cooling loads.

If the cylinder is moved downwards, the intake air beams are more and more changing towards a vertical direction. In this position, the diffuser cylinder is in heating mode and/or heating process.

The diffuser cylinder is adjusted by means of an electric drive.

It can be controlled by hand or fully automatically depending on the temperature difference between air outlet and working area.

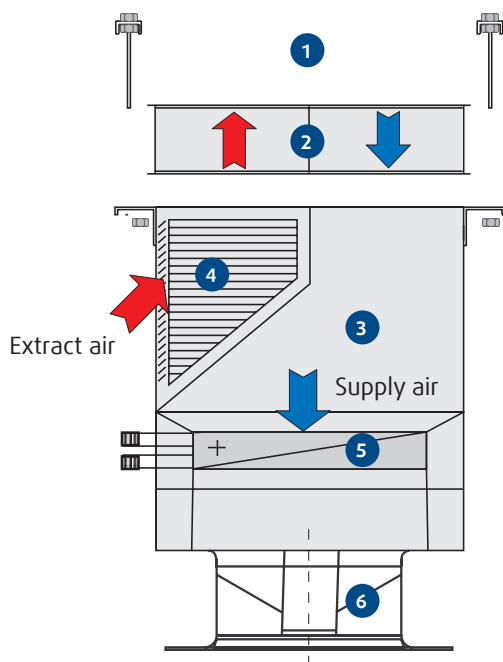

- 1 Suspensions
- 2 Transition duct piece
- 3 Indoor part with connection and suspension
- 4 Extract air grille
- 5 Air heater
- 6 Variable swirl diffuser



Variable swirl diffuser

Dimensions and data

Indoor unit with RotaVent and water heater

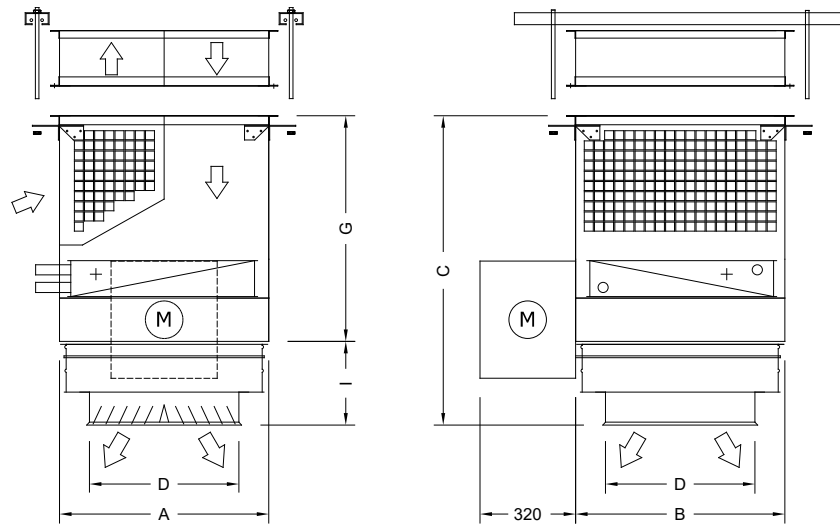

Indoor unit with swirl diffuser and water heater

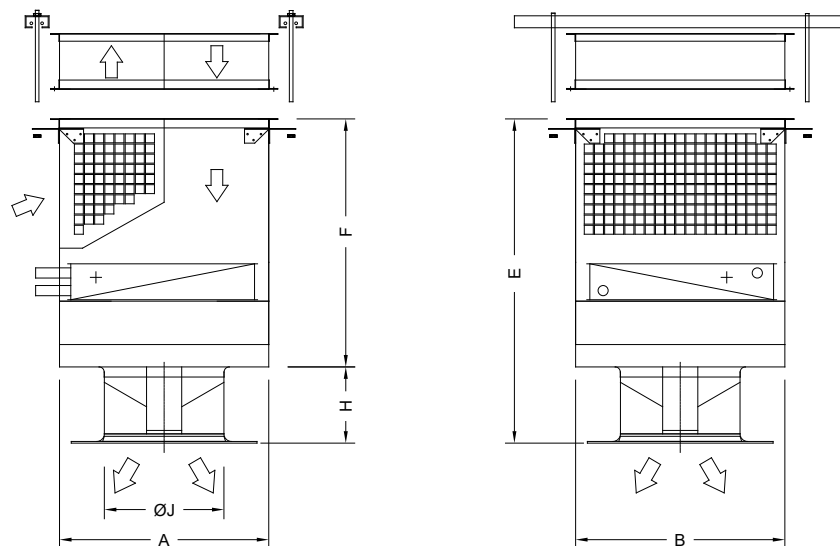

Unit type / Size			035	063	080	130
Nominal air volume flow		m ³ /h	3500	6500	8000	12700
Heating output t LE 5°C, PWW 80/60 °C		kW	21 ... 51	42 ... 106	48 ... 124	71 ... 160
	A / B	mm	700 / 700	1000 / 1000	1000 / 1000	1200 / 1200
Indoor unit with RotaVent (rotating nozzle)						
Total height	C	mm	1035	1165	1365	1370
	G	mm	755	885	1085	1090
	I	mm	280	280	280	280
	D	mm	500	600	600	700
Weight approx.		kg	120	170	190	230
Indoor unit with variable swirl diffuser						
Total height	E	mm	1010	1110	1310	1345
	F	mm	755	755	955	955
	H	mm	255	355	355	390
	øJ	mm	400	630	630	710
Weight approx.		kg	90	130	150	175

Indoor unit with RotaVent, water heater and water cooler

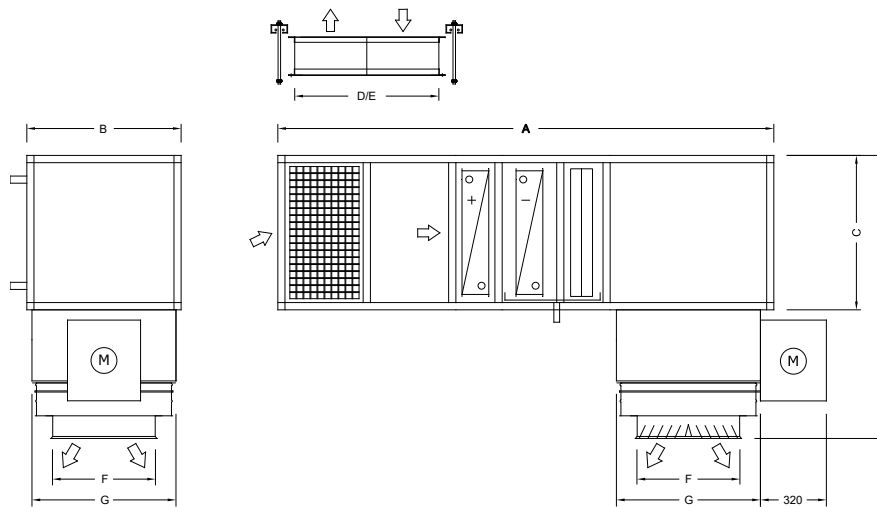

Indoor unit with swirl diffuser, water heater and water cooler

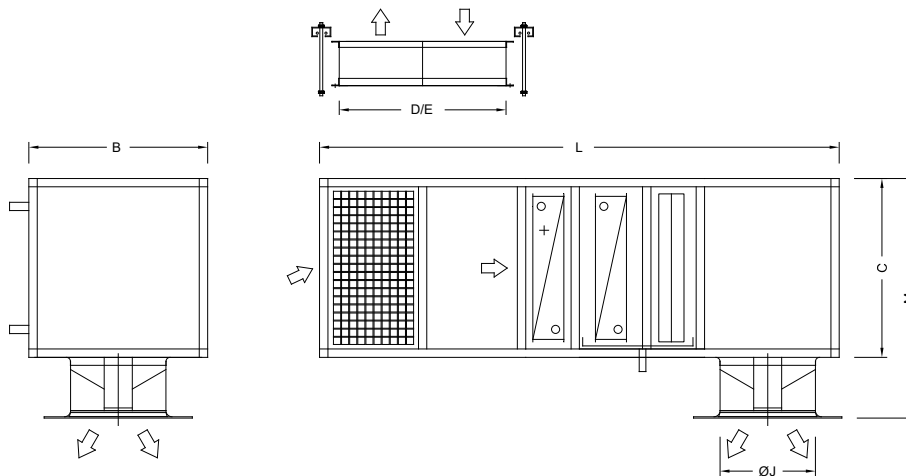

Unit type / Size		035	063	080	130
Indoor unit - horizontal, with RotaVent (rotating nozzle), water heater and water cooler					
A		2330	3080	3080	3395
B		750	1350	1350	1350
C		750	750	750	1050
D / E	mm	700 / 700	1000 / 1000	1000 / 1000	1200 / 1200
F		500	600	600	700
G		700	1000	1000	1200
H		1395	1375	1375	1680
Weight approx. *)	kg	230	380	380	510
Indoor unit - horizontal, with variable swirl diffuser, water heater and water cooler					
L		2330	2700	2700	3115
B		750	1350	1350	1350
C		750	750	750	1050
D / E	mm	700 / 700	1000 / 1000	1000 / 1000	1200 / 1200
Øj		400	630	630	710
M		1005	1105	1105	1440
Weight approx. *)	kg	180	290	290	380

*) ...weight data for heaters with 2 pipe rows and coolers with 3 pipe rows

Heater data

RoofLine 035 at 3500 m ³ /h													
Water heater		1 row				2 rows				3 rows			
PWW	tAI	Q	Vw	dpw	tAO	Q	Vw	dpw	tAO	Q	Vw	dpw	tAO
	°C	kW	m ³ /h	kPa	°C	kW	m ³ /h	kPa	°C	kW	m ³ /h	kPa	°C
90/70 °C	0	25,8	1,15	11,9	21,9	48,4	2,15	9,6	41,1	64,3	2,85	7,8	54,5
	5	24,2	1,07	11	25,5	45,3	2,01	9	43,4	60,1	2,67	7,4	56
	10	22,5	1	10,2	29,1	42,1	1,87	8,4	45,7	55,9	2,48	7	57,4
	15	20,8	0,92	9,4	32,6	39,9	1,73	7,9	48	51,7	2,29	6,6	58,9
80/60 °C	0	22,2	0,98	10,1	18,8	41,6	1,83	8,4	35,3	55,2	2,44	7	46,9
	5	20,5	0,9	9,3	22,4	38,4	1,7	7,8	37,6	51	2,25	6,6	48,3
	10	18,8	0,83	8,6	25,9	35,3	1,56	7,3	39,9	46,8	2,07	6,2	49,7
	15	17,1	0,75	7,9	29,5	30,1	1,42	6,8	42,2	42,6	1,88	5,9	51,2
70/50 °C	0	18,5	0,81	8,5	15,7	34,8	1,52	7,3	29,5	46,2	2,02	6,2	39,2
	5	16,8	0,74	7,8	19,3	31,6	1,39	6,8	31,8	42	1,84	5,9	40,6
	10	15,1	0,66	7,2	22,8	28,4	1,25	6,3	34,1	37,7	1,65	5,6	42
	15	13,4	0,59	6,6	26,3	25,2	1,11	5,9	36,4	33,5	1,47	5,3	43,4
60/40 °C	0	14,8	0,65	7,1	12,6	27,9	1,22	6,3	23,7	37,1	1,62	5,6	31,5
	5	13,1	0,57	6,6	16,1	24,7	1,08	5,9	26	32,8	1,43	5,3	32,9
	10	11,4	0,5	6	19,7	21,5	0,94	5,5	28,3	28,6	1,25	5,1	34,3
	15	9,6	0,42	5,6	23,2	18,3	0,8	5,2	30,5	24,3	1,06	4,9	35,6
55/40 °C	0	14,5	0,84	9	12,3	27,3	1,58	7,6	23,2	36,2	2,1	6,4	30,7
	5	12,8	0,74	8	15,9	21,4	1,4	6,9	25,5	32	1,85	6	32,1
	10	11,1	0,64	7,2	19,4	20,9	1,21	6,3	27,8	27,8	1,61	5,6	33,6
	15	9,38	0,54	6,4	23	17,7	1,03	5,8	30	23,5	1,36	5,2	35
45/35 °C	0	12,5	1,08	12	10,6	23,4	2,02	9,7	19,8	30,9	2,68	7,8	26,2
	5	10,8	0,93	10,1	14,1	20,2	1,75	8,4	22,1	26,7	2,31	6,9	27,7
	10	9,05	0,78	8,5	17,7	17	1,47	7,3	24,4	22,5	1,95	6,2	29,1
	15	7,3	0,63	7,1	21,2	13,8	1,19	6,3	26,7	18,3	1,58	5,6	30,5

RoofLine 063 at 6500 m ³ /h													
Water heater		1 row				2 rows				3 rows			
PWW	tAI	Q	Vw	dpw	tAO	Q	Vw	dpw	tAO	Q	Vw	dpw	tAO
		kW	m ³ /h	kPa	°C	kW	m ³ /h	kPa	°C	kW	m ³ /h	kPa	°C
90/70 °C	0	52,7	2,34	7,4	24,1	97,5	4,33	8,4	44,6	132,6	5,88	11,5	60,6
	5	49,2	2,19	7	27,5	91,2	4,05	7,9	46,7	124,2	5,51	10,6	61,8
	10	45,8	2,03	6,7	30,9	84,9	3,77	7,4	48,8	115,8	5,14	9,9	62,9
	15	42,4	1,88	6,4	34,4	78,5	3,49	7	50,9	107,4	4,77	9,1	64,1
80/60 °C	0	45,2	1,99	6,7	20,7	83,9	3,7	7,4	38,3	114,8	5,06	9,9	52,5
	5	41,8	1,84	6,3	24,1	77,5	3,42	7	40,4	106,4	4,69	9,1	53,6
	10	38,2	1,69	6	27,5	71,2	3,14	6,6	42,5	98	4,32	8,5	54,8
	15	34,9	1,54	5,7	30,9	64,8	2,86	6,2	44,6	89,6	3,95	7,8	55,9
70/50 °C	0	37,8	1,66	6	17,3	70,1	3,08	6,6	32,1	97	4,25	8,5	44,3
	5	34,3	1,5	5,7	20,7	63,8	2,8	6,2	34,1	88,6	3,88	7,8	45,5
	10	30,8	1,35	5,5	24,1	57,4	2,52	5,9	36,2	80,1	3,51	7,2	46,6
	15	27,3	1,2	5,2	27,5	50,9	2,23	5,6	38,3	71,6	3,14	6,7	47,7
60/40 °C	0	30,2	1,32	5,5	13,8	56,4	2,46	5,9	25,8	79,1	3,45	7,2	36,1
	5	26,8	1,17	5,2	17,2	50	2,18	5,5	27,8	70,6	3,08	6,7	37,3
	10	23,3	1,01	5	20,6	43,5	1,9	5,3	29,9	62,1	2,71	6,2	38,4
	15	19,7	0,86	4,8	24	37,1	1,62	5	31,9	53,5	2,33	5,7	39,4
55/40 °C	0	29,6	1,72	6,2	13,5	55,1	3,19	6,9	25,2	76,2	4,42	9	34,8
	5	26,2	1,52	5,8	17	48,7	2,82	6,3	27,3	67,8	3,93	8,1	36
	10	22,7	1,31	5,5	20,4	42,3	2,45	5,9	29,3	59,3	3,44	7,2	37,1
	15	19,2	1,11	5,1	23,8	35,8	2,08	5,5	31,4	50,8	2,95	6,5	38,2
45/35 °C	0	25,5	2,21	7,4	11,7	47,1	4,08	8,4	21,5	64,6	5,59	11,7	29,5
	5	22	1,9	6,7	15	40,7	3,52	7,5	23,6	56,2	4,86	10	30,7
	10	18,5	1,6	6	18,5	34,3	2,97	6,6	25,7	47,7	4,13	8,5	31,8
	15	14,9	1,29	5,5	21,8	27,9	2,41	5,9	27,8	39,3	3,4	7,3	33

RoofLine 080 at 8000 m ³ /h													
Water heater		1 row				2 rows				3 rows			
PWW	tAI	Q	Vw	dpw	tAO	Q	Vw	dpw	tLA	Q	Vw	dpw	tAO
		kW	m ³ /h	kPa	°C	kW	m ³ /h	kPa	°C	kW	m ³ /h	kPa	°C
90/70 °C	0	59,8	2,65	8,2	22,2	111,9	4,96	9,5	41,5	153,6	6,82	13,7	57
	5	56	2,49	7,8	25,7	104,9	4,65	8,9	43,7	144,5	6,41	12,7	58,3
	10	52,1	2,31	7,3	29,2	97,7	4,33	8,4	46	134,9	5,99	11,7	59,6
	15	48,3	2,14	6,9	32,7	90,4	4,01	7,8	48,2	125,3	5,56	10,7	60,9
80/60 °C	0	51,3	2,26	7,3	19	96,1	4,24	8,3	35,7	133	5,86	11,6	49,4
	5	47,5	2,09	6,9	22,5	89	3,93	7,8	37,9	123,6	5,45	10,7	50,6
	10	43,6	1,92	6,5	26,1	81,8	3,61	7,3	40,1	114	5,03	9,8	52
	15	39,7	1,75	6,1	29,6	74,5	3,29	6,8	42,3	104,3	4,6	9	53,3
70/50 °C	0	42,8	1,88	6,5	15,9	80,3	3,52	7,2	29,8	112,2	4,92	9,7	41,7
	5	39,9	1,71	6,1	19,4	73,2	3,21	6,8	32	102,8	4,5	8,9	42,9
	10	35	1,53	5,8	22,9	65,9	2,89	6,3	34,3	93	4,08	8,1	44,2
	15	31,1	1,36	5,5	26,4	58,5	2,56	5,9	36,5	83,2	3,65	7,4	45,6
60/40 °C	0	34,2	1,49	5,8	12,7	64,4	2,81	6,3	23,9	91,4	3,98	8,1	33,9
	5	30,4	1,32	5,5	16,2	57,2	2,49	5,9	26,1	81,8	3,57	7,4	35,2
	10	26,4	1,15	5,2	19,7	49,9	2,17	5,5	28,4	71,9	3,13	6,7	36,5
	15	22,4	0,98	4,9	23,2	42,4	1,85	5,2	30,6	62	2,7	6,2	37,8
55/40 °C	0	33,6	1,95	6,7	12,5	63	3,65	7,6	23,4	88,2	5,11	10,4	32,7
	5	29,7	1,72	6,2	16	55,8	3,24	6,9	25,6	78,6	4,56	9,2	34
	10	25,8	1,49	5,8	19,5	48,5	2,81	6,3	27,9	68,8	3,99	8,2	35,4
	15	21,8	1,26	5,4	23	41,1	2,38	5,8	30,1	59	3,42	7,2	36,7
45/35 °C	0	28,9	2,5	8,3	10,7	53,9	4,67	9,6	20	74,8	6,48	14	27,8
	5	25	2,17	7,3	14,2	46,7	4,05	8,4	22,3	65,2	5,65	11,8	29,1
	10	21	1,82	6,5	17,7	39,4	3,41	7,3	24,5	55,5	4,8	9,9	30,4
	15	17	1,47	5,8	21,3	32	2,77	6,3	26,8	45,6	3,95	8,2	31,8

RoofLine 130 at 13000 m ³ /h													
Water heater		1 row				2 rows				3 rows			
PWW	tAI	Q	Vw	dpw	tAO	Q	Vw	dpw	tLA	Q	Vw	dpw	tAO
		kW	m ³ /h	kPa	°C	kW	m ³ /h	kPa	°C	kW	m ³ /h	kPa	°C
90/70 °C	0	92,9	4,12	8,3	21,2	152,7	6,78	10	34,9	203,3	9,16	11,1	47,1
	5	86,8	3,85	7,8	24,8	142,8	6,34	9,3	37,6	193,1	8,57	10,3	49,1
	10	80,6	3,58	7,3	28,4	133	5,9	8,7	40,4	179,7	7,98	9,5	51,1
	15	74,4	3,3	6,9	32	123,1	5,46	8,1	43,1	166,3	7,38	8,8	53
80/60 °C	0	79,4	3,5	7,3	18,2	131,4	5,8	8,6	30	177,6	7,83	9,5	40,6
	5	73,3	3,23	6,9	21,7	121,6	5,36	8,1	32,8	164,3	7,25	8,8	42,6
	10	67,1	2,96	6,5	25,3	111,7	4,93	7,5	35,5	150,9	6,66	8,1	44,5
	15	60,9	2,69	6,1	28,9	101,7	4,49	7	38,2	137,4	6,06	7,5	46,4
70/50 °C	0	66	2,89	6,5	15,1	110,1	4,83	7,5	25,2	148,9	6,53	8	34
	5	59,8	2,62	6,1	18,7	100,3	4,4	7	27,9	135,4	5,94	7,4	36
	10	53,7	2,35	5,8	22,3	90,3	3,96	6,5	30,6	122	5,35	6,8	37,9
	15	47,4	2,08	5,5	25,8	80,3	3,52	6,1	33,3	108,5	4,76	6,3	39,8
60/40 °C	0	52,5	2,29	5,8	12	88,8	3,87	6,5	20,3	119,9	5,23	6,8	27,4
	5	46,4	2,02	5,5	15,6	78,9	3,44	6	23	106,5	4,64	6,3	29,3
	10	40,1	1,75	5,2	19,2	68,8	3	5,6	25,7	92,9	4,05	5,8	31,2
	15	33,8	1,47	4,9	22,7	58,8	2,56	5,3	28,4	79,3	3,46	5,4	33,1
55/40 °C	0	51,8	3,01	6,7	11,8	86,6	5,02	7,9	19,8	116,8	6,77	8,4	26,7
	5	45,6	2,65	6,2	15,4	76,7	4,44	7,1	22,5	103,4	6	7,6	28,6
	10	39,4	2,28	5,8	19	66,7	3,87	6,5	25,2	90	5,22	6,8	30,6
	15	33,1	1,92	5,4	22,6	56,6	3,28	5,9	27,9	76,4	4,43	6,1	32,5
45/35 °C	0	44,7	3,87	8,3	10,2	74	6,41	10	16,9	99,7	8,63	11	22,8
	5	39,4	3,32	7,3	13,8	64,1	5,55	8,7	19,6	86,3	7,47	9,4	24,7
	10	32,2	2,79	6,5	17,4	54,1	4,68	7,5	22,4	72,8	6,3	8	26,6
	15	25,9	2,24	5,8	20,9	44	3,81	6,5	25,1	59,3	5,14	6,8	28,6

Roof frame

Roof frame made of aluminium AlMg3, for the installation of the RoofLine outdoor unit. The roof frame is incorporated in the roofing in a water-proof way. The design of the roof frame must be negotiated in the order process; later modifications are not possible. For buildings

with raised crane tracks where the indoor part would extend downwards too much, the height of the roof frame can be increased so that most of the indoor part reaches into the roof.

Flat roof frame

Flat roof frame is made of aluminium AlMg3, for the installation of the RoofLine outdoor unit on a flat roof; suited for all roof constructions. Interior insulation, 50 mm thick.

Recommended installation - outdoor air away from the main weather side, if possible.

Order information:

- Roof type
- Total height of roof structure

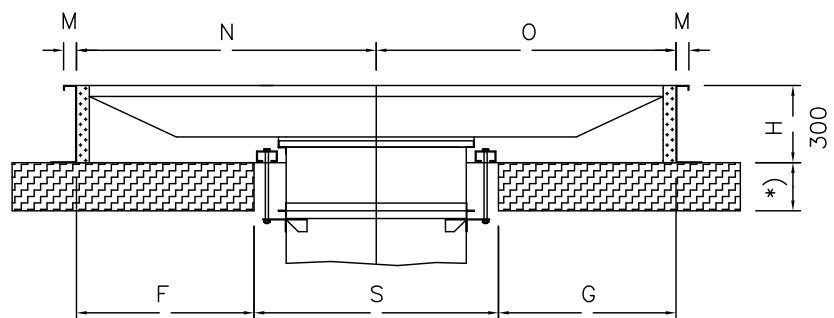

Sloped roof frame

Design as flat roof frame, for installation of the RoofLine outdoor unit on a pitched roof. Recommended installation - exhaust air outlet oriented towards gable (long side of the unit towards roof slope).

Order information:

- Roof type
- Total height of roof structure
- Roof slope in degree or in %
- Long side of the unit in longitudinal direction of the roof slope (standard)
- Long side of the unit transversely to the roof slope

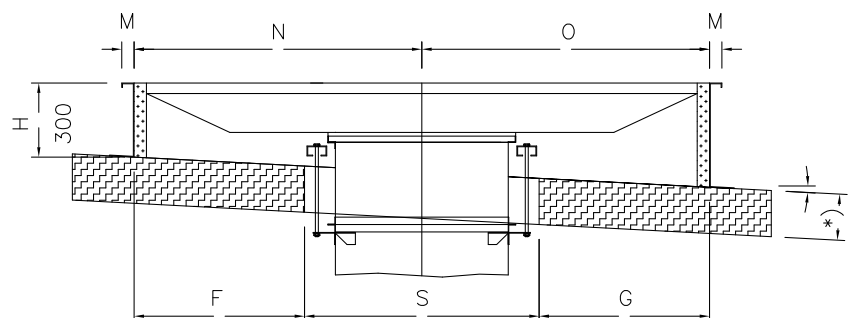

Double sloped roof frame

Design as flat roof frame, for installation of the RoofLine outdoor unit on the roof gable.

The exhaust air outlet can be oriented to both sides.

Recommended installation - exhaust air outlet towards one of the roof slopes (long side of the unit transversely to the roof gable), outdoor air away from the main weather side.

Order information:

- Roof type
- Total height of roof structure
- Roof slope on both sides in degree or in %
- Long side of the unit transversely to the roof gable (standard)
- Long side of the unit in longitudinal direction of the roof gable

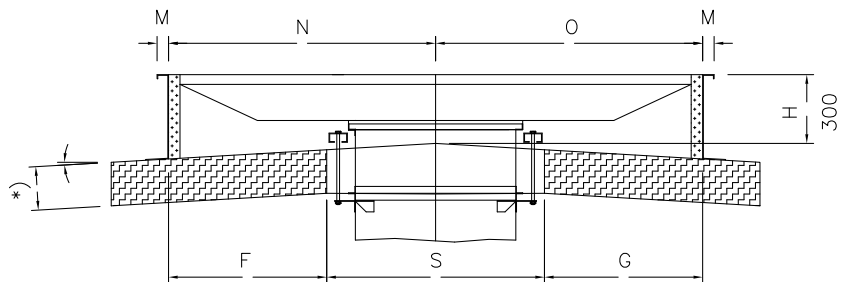

Further designs, adjustment to existing roof sections etc. on request

Either, **the roof frame is installed** on the roof at first, then the interior part is installed from above, followed by the installation of the roof ventilation device.

Or, the interior part is installed from below after the installation of the roof ventilation device.

Preparing for installation:

Prepare the roof cut-out according to the table below and build a sub-construction appropriate for the roof construction and which is able to bear the weight. Carry out any required exchange of the load-bearing structure e.g. for trapezoidal sheet metal with timber planks or form tubes.

Observe statically determined requirements for the roof construction and fastening!

Dimensions

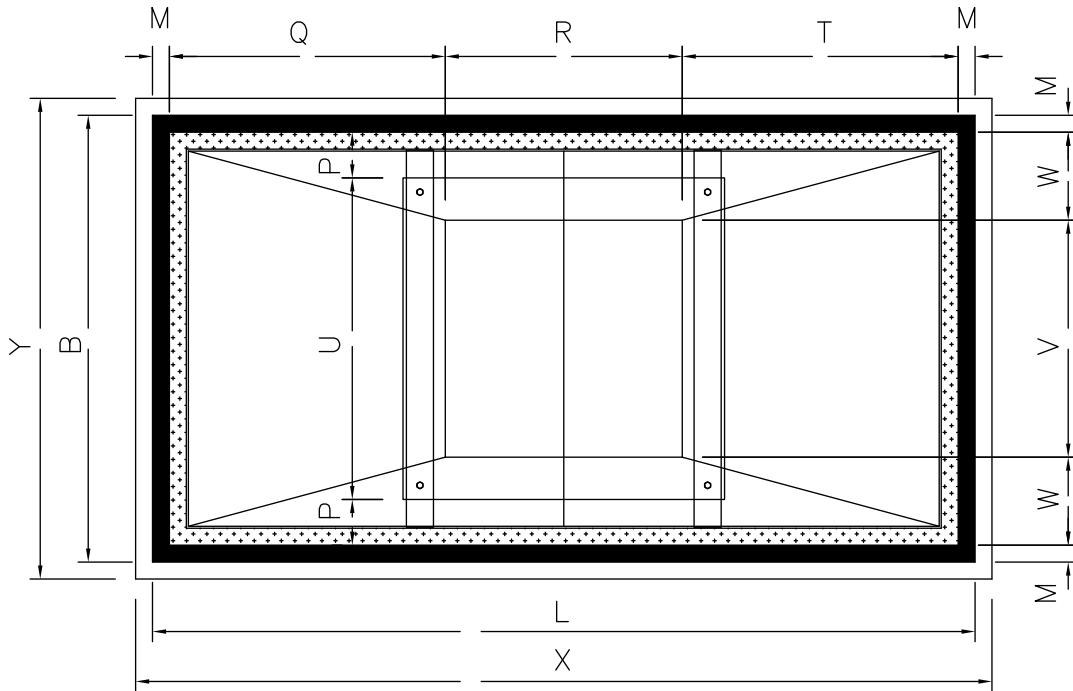

Device type / size			035	063	080	130
Flat roof frame						
Length	L	mm	2600	2880	2880	3300
Width	B	mm	1320	1580	1950	2240
Height	H	mm	300	300	300	300
Weight approx.		kg	70	90	105	130
Total length	X	mm	2700	2980	2980	3400
Total width	Y	mm	1420	1680	2050	2340
	M	mm	50	50	50	50
	N	mm	1250	1390	1390	1600
	O	mm	1250	1390	1390	1600
	Q	mm	900	890	890	1000
	R	mm	700	1000	1000	1200
	T	mm	900	890	890	1000
	V	mm	700	1000	1000	1200
	W	mm	260	240	425	470
Sloped roof frame			Corresponding to the roof slope			
Double sloped roof frame - gable installation			Corresponding to the roof slope			
Lining distance		mm	2500 x 1220	2780 x 1480	2780 x 1850	3200 x 2140
Roof opening	S	mm	1060	1360	1360	1560
	U	mm	1060	1360	1360	1560
	F	mm	720	710	710	820
	G	mm	720	710	710	820
	P	mm	80	60	245	290
Roof ransion roof piece						
Length and weight			Corresponding to the height of the roof construction. (Please specify in your order.)			

Roof frame installation

Position the roof frame on the prepared, load-bearing sub-structure and align in the roof orientation in both directions so that the location surface for the roof device is horizontal.

Fasten the roof frame with suitable, stainless steel screws in distances of approx. 20 cm on all sides in the sub-structure. The holes in the roof frame flange must be drilled by the customer.

Position insulation wedges contacting the roof frame so that the roof cladding can be pulled up at the roof frame up to under the circumferential edge.

If required, cover the end of the roof cladding in a water-proof manner.

Roof frame installation on trapezoidal sheet metal

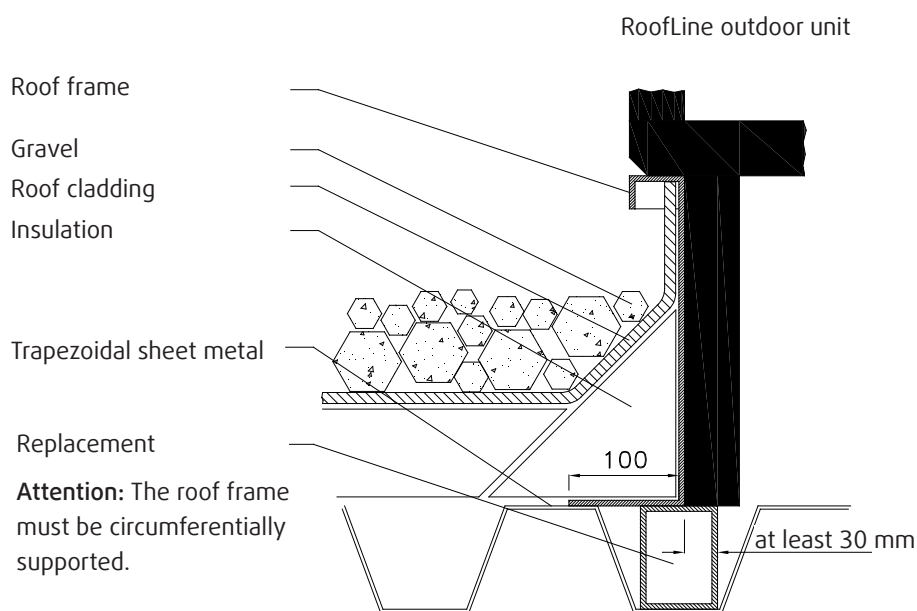

How to select and order

General ordering code:

RL-080-OR-S-IVRR-HC-S-FF

	Roof frame	FF FS FD	Flat roof Sloped roof Double sloped roof
	Silencer (or the supply air inside of the transition duct piece)	S -	With silencer Without silencer
	Heater / Cooler	H RC HC	Water heating coil Reversible coil (water heating / cooling) Water heating + water cooling coil
	Diffuser type	R D	Rotavent (Rotating nozzle) Swirl diffuser
	Service side of indoor unit	L R	Left Right
	Execution	V H	Vertical Horizontal
	Indoor unit		
	Silencer (on the opening for the exhaust air)	S -	With silencer Without silencer
	Service side (framed on supply air direction)	L R	Left Right
	Outdoor unit		
	Size	035, 063, 080, 130	
	Product name	RL	RoofLine

NOTE:

At the order confirmed data from the selection program must be enclosed and the details of the shape and dimensions of the roof frame (see section roof frame) clearly confirmed by the customer.

Air direction variants

Right

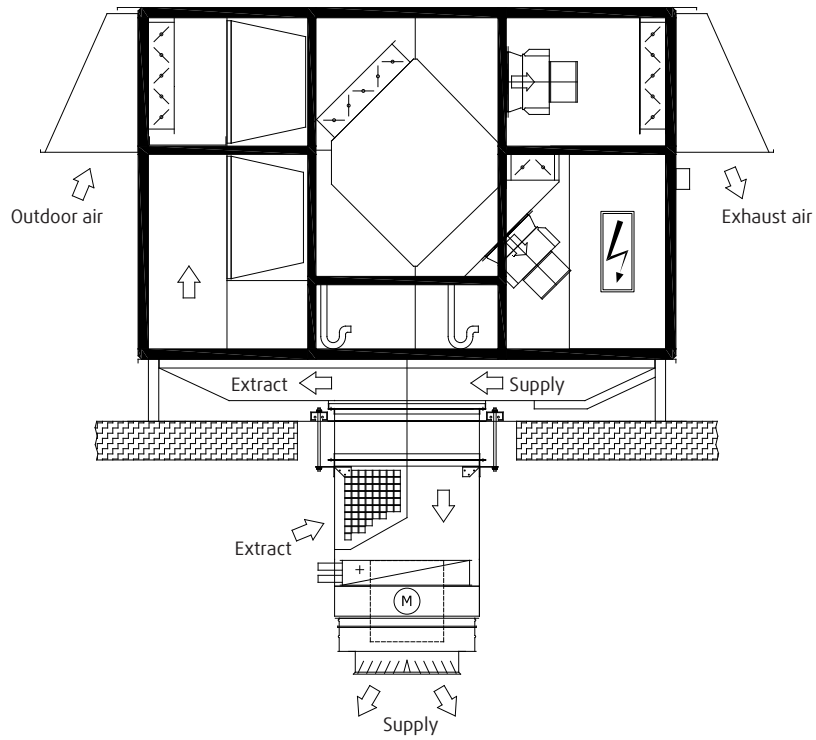

Left

