

Roof fans DVN(I), DVS(I), DVC(I), DHS, DHA

Installation and Operating Instructions

GB

Document in original language | · 008

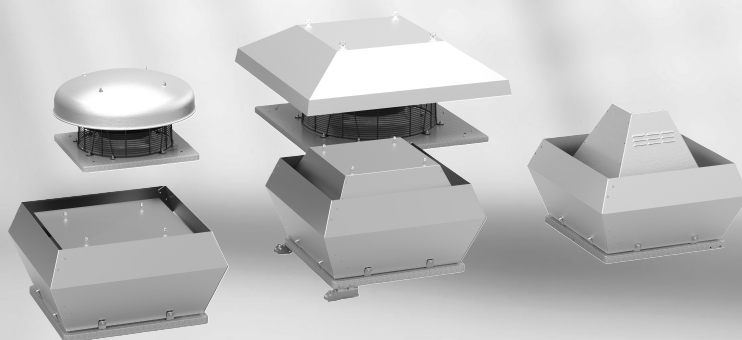

© Copyright Systemair AB
All rights reserved
E&OE

Systemair AB reserves the rights to alter their products without notice.
This also applies to products already ordered, as long as it does not affect the previously agreed specifications.

Contents

1	General information	1
1.1	Warning symbols	1
1.1.1	Instruction symbols	1
2	Important safety information	1
2.1	Personnel	1
2.2	Personal protective equipment	2
2.3	5 rules of electrical safety	2
3	Warranty	2
4	Delivery, transport, storage	2
5	Description	3
5.1	Intended use	3
5.2	Technical data	4
5.3	Description DVN/DVNI	4
5.4	Description DVS/DVSI	5
5.5	Description DVC/DVCI	6
5.6	Description DHS	8
5.7	Description DHA	8
6	Name plate and type key	9
7	Accessories	10
8	Installation	11
8.1	Installation of the ventilation system	11
8.1.1	DVC-P measuring tubes	12
8.2	Assembly/Disassembly impeller – Internal rotor motor	12
8.3	Assembly tilting device (FTG)	14
9	Electrical connection	14
9.1	Electrical connection accessories	15
9.2	Protecting the motor	16
9.3	Variable-speed fans	16
10	Commissioning	16
11	Operation	17
12	Troubleshooting/maintenance/repair	17
12.1	Troubleshooting	17
12.2	Maintenance	19
13	Cleaning	20
14	Deinstallation/dismantling	20
15	Disposal	20
16	Commissioning Report	20

1 General information

1.1 Warning symbols



Note:

Useful information and instructions

1.1.1 Instruction symbols

Instruction

- ◆ Carry out this action
- ◆ (if applicable, further actions)

Instruction with fixed sequence

- | | |
|--|---|
| <ol style="list-style-type: none"> 1. Carry out this action 2. Carry out this action | <ol style="list-style-type: none"> 3. (if applicable, further actions) |
|--|---|

2 Important safety information

Planners, plant builders and operators are responsible for the proper assembly and intended use.

- ◆ Read the operating instructions completely and carefully.
- ◆ Keep the operating instructions and other valid documents, such as the circuit diagram or motor instructions, with the fan. They must always be available at the place of use.
- ◆ Observe and respect local conditions, regulations and laws.
- ◆ Abide by the system-related conditions and requirements of the system manufacturer or plant constructor.
- ◆ Safety elements may not be dismantled, circumvented or deactivated.
- ◆ Only use the fan in a flawless condition.
- ◆ Provide generally prescribed electrical and mechanical protective devices.
- ◆ During installation, electrical connection, commissioning, troubleshooting, and maintenance, secure the location and premises against unauthorised access.
- ◆ Do not circumvent any safety components or put them out of action.
- ◆ Before any work on the fan, test absence of voltage.
Even when the motor is stopped, dangerous voltages may be present on terminals.
- ◆ Keep all the warning signs on the fan complete and in a legible condition.
- ◆ The device is not to be used by persons (including children) with reduced physical, sensory or mental capabilities, or lack of experience and knowledge, unless they have been given supervision or instruction.
- ◆ When lifting the device, use suitable lifting gear.
- ◆ Do not allow children to play with the device.

2.1 Personnel

The fan may only be used by qualified, instructed and trained personnel. The persons must know the relevant safety directives in order to recognise and to avoid risks. The individual activities and qualifications can be found in Table 1 *Qualifications*, page 2.

Table 1 Qualifications

Activities	Qualifications	
Storage, operation, transport, cleaning, disposal	Trained personnel (see following note)	
Electrical connection, commissioning, electrical disconnection	Electrical expert or matching qualification	
Installation, disassembly	Fitter or matching qualification	
Maintenance	Electrical expert or matching qualification	Fitter or matching qualification
Repair	Electrical expert or matching qualification	Fitter or matching qualification
	Smoke extraction fans and EX fans only by agreement with Systemair.	

**Note:**

The operator is responsible for ensuring that personnel are instructed and have understood the contents of the operating instructions. If something is unclear, please contact Systemair or its representative.

2.2 Personal protective equipment

◆ Wear protective equipment during all work in the vicinity of the fan.

- protective working clothes
- protective working gloves
- goggles
- protective working shoes
- helmet
- hearing protection

2.3 5 rules of electrical safety

1. Disconnect (disconnection of the electrical system from live components at all terminals)
2. Prevent reactivation
3. Test absence of voltage
4. Ground and short-circuit
5. Cover or restrict adjacent live parts

3 Warranty

For the assertion of warranty claims, the products must be correctly connected and operated, and used in accordance with the data sheets. Further prerequisites are a completed maintenance plan with no gaps and a commissioning report. Systemair will require these in the case of a warranty claim. The commissioning report is a component of this document. The maintenance plan must be created by the operator, see section Maintenance.

4 Delivery, transport, storage

Safety information

Warning: Risk from rotating fan blades

◆ Prevent access by unauthorised persons by safety personnel or access protection.

Warning: Suspended loads

- ◆ Do not walk under suspended loads.
- ◆ Make sure that there is nobody under a suspended load.

Delivery

Each fan leaves our plant in an electrically and mechanically proper condition. We recommend transporting the fan to the installation site in the original packaging.

Checking delivery

- ◆ Check the packaging and the fan for transport damage. Any findings should be noted on the cargo manifest.
- ◆ Check completeness of the delivery.

Unpacking

When opening the transport packaging, there is a risk of damage from sharp edges, nails, staples, splinters etc.

- ◆ Unpack the fan carefully.
- ◆ Check the fan for obvious transport damage.
- ◆ Only remove the packaging shortly before assembly.

Transport

Safety information

Warning: Electrical or mechanical hazards due to fire, moisture, short circuit or malfunction.

- ◆ Never transport the fan by the connecting wire, terminal box, impeller, protection grille, inlet cone or silencer.
- ◆ In open transport, please make sure that no water can penetrate into the motor or other sensitive parts.
- ◆ We recommend transporting the fan to the installation site in the original packaging.

Caution: If transported without care during loading and unloading, the fan may be damaged.

- ◆ Load and unload the fan carefully.
- ◆ Use hoisting equipment that is suitable for the weight to be hoisted.
- ◆ Observe the transportation arrows on the packaging.
- ◆ Use the fan packaging exclusively as transport protection and not as a lifting aid.

Storage

- ◆ Store the fan in the original packaging in a dry, dust-free location protected against weather.
- ◆ Avoid the effects of extreme heat or cold.

Hazard due to loss of function of the motor bearing

- ◆ Avoid storing for too long (recommendation: max. 1 year).
- ◆ Check that the motor bearing functions properly before installation.

5 Description

5.1 Intended use

Roof fans DVN(I),DVS(I),DVC(I),DHS

- The fans are intended for installation in ventilation systems. They can be installed both in duct systems and also with free suction via an inlet cone and a suction-side contact protection grille. Systemair recommends a Back draft damper (VKS) to avoid cold air intake at a standstill of the fan, see 7 *Accessories*, page 10.
- The fans are exclusively intended for extract air applications.

Roof fans DHA

- The fans are intended for installation in ventilation systems. They can be installed both in duct systems and also with free outlet side via a protection grille.
- The fans are exclusively intended for air supply applications.

DVN, DVNI

- The fan is suitable for conveying contaminated air (dust, kitchen exhaust).
- The fan is applicable exhaust ventilation with a maximum constant airflow temperature of 120 °C.

DVS, DVSI, DVC, DVCI, DHS, DHA

- The fan is suitable for conveying clean air.

Incorrect use

Incorrect use refers mainly to using the fan in another way to that described. The following examples are incorrect and hazardous:

- Conveying of explosive and combustible media
- Conveying of aggressive media
- Operation in an explosive atmosphere
- Operation without duct system or protection grille
- Operation with the air connections closed

5.2 Technical data

Max. ambient temperature [°C]

Max. temperature of transported air [°C]

see data sheet, available in our online catalogue.

Sound pressure [dB]

Voltage, current, frequency, enclosure class, weight

see name plate of the fan

The motor data can be found on the name plate of the motor, or in the technical documents of the motor manufacturer.

The data on the name plate of the fan apply to "standard air" according to ISO 5801.

5.3 Description DVN/DVNI

Table 2 Dimensions DVN

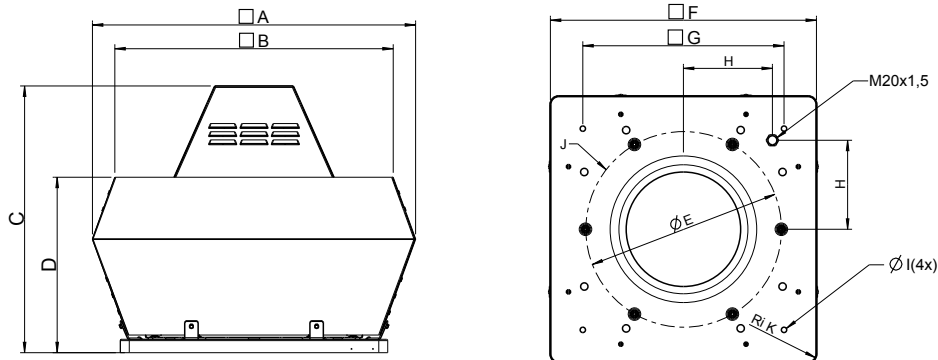

[mm]	A	B	C	D	E	F	G	H	I	J	K
355–400	720	618	600	390	438	595	450	200	12(4x)	6xM8	18.5
450–500	900	730	675	465	438	665	535	237	12(4x)	6xM8	18.5
560–630	1150	955	900	560	605	939	750	293	14(4x)	8xM8	0
710	1350	1178	936	660	674	1035	840	320	14(4x)	8xM8	0
800–900	1690	-	1180	830	872	1255	1050	433	14(4x)	8xM8	0

Table 3 Dimensions DVNI

[mm]	A	B	C	D	E	F	G	H	I	J	K
355–400	874	648	600	439	438	595	450	200	12(4x)	6xM8	18.5
450–500	970	730	675	479	438	665	535	237	12(4x)	6xM8	18.5
560–630	1315	1035	900	600	605	939	750	293	14(4x)	8xM8	0
710	1483	1165	936	729	674	1035	840	320	14(4x)	8xM8	0
800–900	1590	-	1180	830	872	1255	1050	433	14(4x)	8M8	0

5.4 Description DVS/DVSI

Table 4 Dimensions DVS

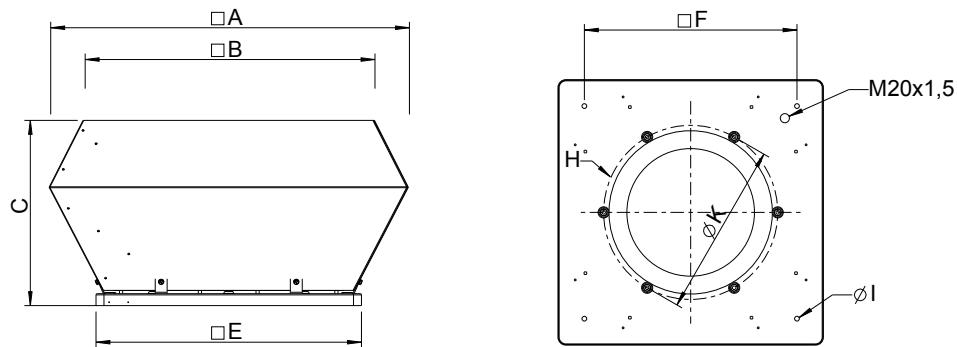

[mm]	A	B	C	E	F	H	K	I
190-225	370	320	175	335	245	6xM6	213	10(4x)
310-311	560	470	330	435	330	6xM8	285	10(4x)
355-400	723	623	390	595	450	6xM8	438	12(4x)
450-500	900	730	465	665	535	6xM8	438	12(4x)
560-630	1150	960	565	939	750	8xM8	605	14(4x)
710	1350	1185	660	1035	840	8xM8	674	14(4x)

Table 5 Dimensions DVSI

[mm]	A	B	C	E	F	H	K	I
190-225	498	438	210	335	245	6xM6	213	10(4x)
310-311	695	584	370	435	330	6xM8	285	10(4x)
355-400	877	745	440	595	450	6xM8	438	12(4x)
450-500	970	825	479	665	535	6xM8	438	12(4x)
560-630	1315	1130	600	939	750	8xM8	605	14(4x)
710	1483	1185	729	1035	840	8xM8	674	14(4x)

5.5 Description DVC/DVCI

S-Version:

The DVC-S version can be stepless controlled via a 0-10 V signal. The operating point can be directly adjusted with the integrated potentiometer (10 K ohms).

POC-Version

The DVC-POC version has integrated pressure sensors and temperature sensor for outdoor temperature compensation. The electronics can be programmed for a constant pressure operation with or without outdoor temperature compensation (The factory setting is with outdoor temperature compensation). For any details of the controller, please see the separate attached controller manual.

P-Version:

The DVC-P version has integrated pressure sensors and the electronic is programmed for a constant pressure operation. For any details of the controller, please see the separate attached controller manual.

This version can also be ordered as CAV (constant air volume).

Table 6 K-factor (measured values) DVC-P

315-P EC	103	450-P EC	245	560-P EC	298
355-P EC	143	450-K-P EC	253	630-P EC	498
400-P EC	207	500-P EC	365	710-P EC	628

Table 7 Dimensions DVC-S

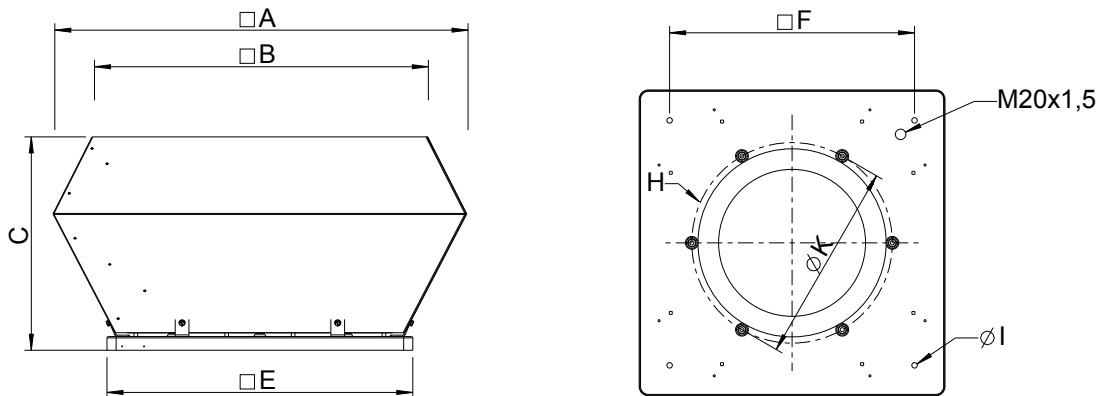

[mm]	A	B	C	E	F	H	K	I
190-225	370	320	175	335	245	6xM6	213	10(4x)
315	560	470	330	435	330	6xM8	285	10(4x)
355-400	723	623	390	595	450	6xM8	438	12(4x)
450-500	900	730	465	665	535	6xM8	438	12(4x)
560-630	1150	960	565	939	750	8xM8	605	14(4x)

Table 8 Dimensions DVCI-S

[mm]	A	B	C	E	F	H	K	I
190-225	498	438	210	335	245	6xM6	213	10(4x)
315	695	584	370	435	330	6xM8	285	10(4x)
355-400	874	648	439	595	450	6xM8	438	12(4x)
450-500	970	730	479	665	535	6xM8	438	12(4x)
560-630	1315	1130	600	939	750	8xM8	605	14(4x)

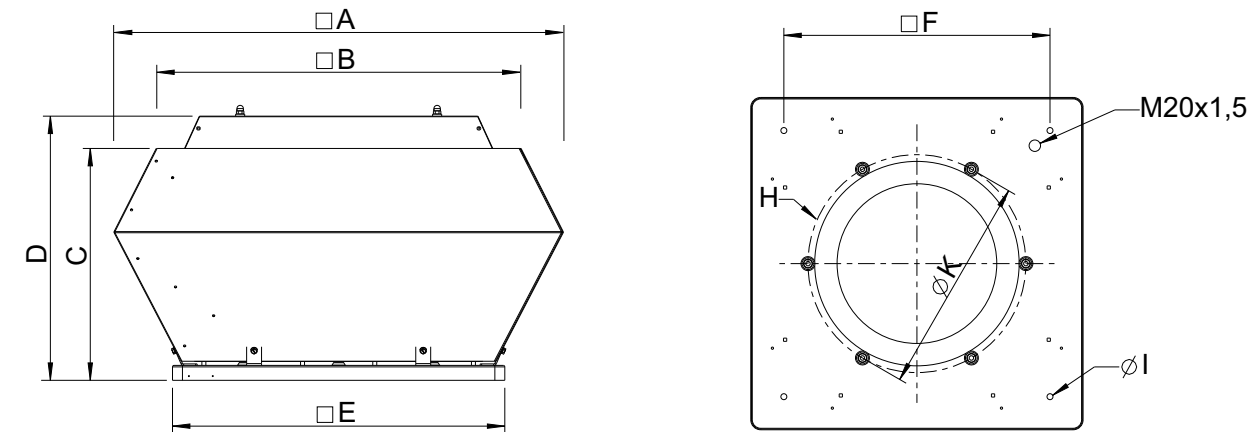
Table 9 Dimensions DVC-P/DVC-POC

[mm]	A	B	C	D	E	F	H	K	I
190-225	370	320	175	-	335	245	6xM6	213	10 (4x)
315	560	470	330	378	435	330	6xM8	285	10 (4x)
355-400	723	623	390	438	595	450	6xM8	438	12 (4x)
450-500	900	730	465	515	665	535	6xM8	438	12 (4x)
560-630	1150	960	565	585	939	750	8xM8	605	14(4x)

Table 10 Dimensions DVCI-P/DVCI-POC

[mm]	A	B	C	D	E	F	H	K	I
225	498	438	210	-	335	245	6xM6	213	10(4x)
315	690	583	369	415	435	330	6xM6	285	10(4x)
355-400	877	745	440	439	595	450	6xM8	438	12(4x)
450-500	970	825	479	516	665	535	6xM8	438	12(4x)
560-630	1315	1135	600	619	939	750	8xM8	605	14(4x)

5.6 Description DHS

The fans are equipped with AC motors. For information on speed regulation options, see 6 Name plate and type key, page 9.

Table 11 Dimensions DHS

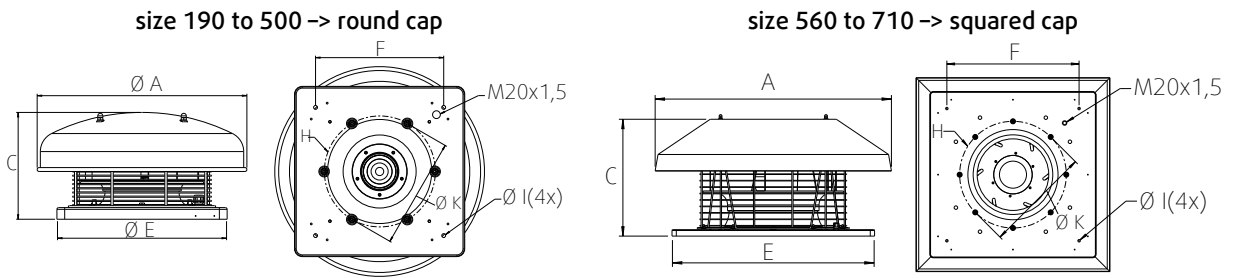

[mm]	A	C	E	F	H	K	I
190-225	417	150	335	245	6xM6	213	10(4x)
310-315	540	250	435	330	6xM8	285	10(4x)
355-400	720	330	595	450	6xM8	438	12(4x)
450-500	830	490	665	535	6xM8	438	12(4x)
560-630	1100	535	939	750	8xM8	605	14(4x)
710	1282	580	1035	840	8xM8	674	14(4x)

5.7 Description DHA





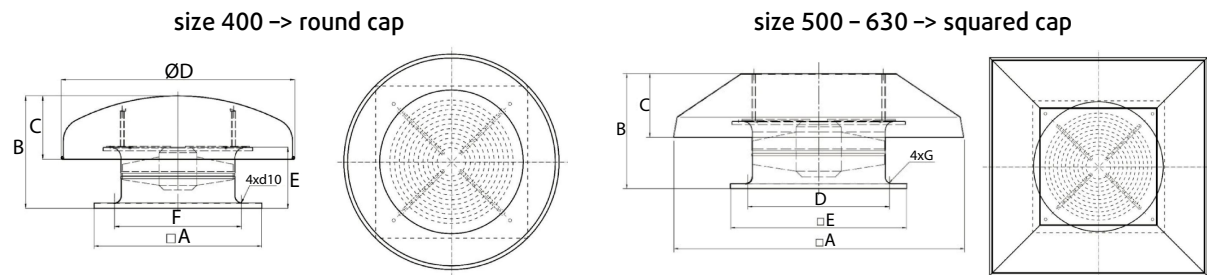

The fan is an axial supply air fan equipped with Voltage controllable external rotor motors.

Table 12 Dimensions DHA

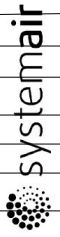

[mm]	A	B	C	D	E	F	G
400	595	399	225	830	216	450	-
500	1100	434	240	535	665	-	12(4x)
630	1282	481	240	750	939	-	14(4x)

6 Name plate and type key

1		DVNI 560D4			  	8
2		400 V~	4,42 A	50 Hz		
3				2585 W		
4		tF= 120°C				
5		IP55	1462 min ⁻¹	104,6kg		
6		INS.CL.F				
7			Serial.no: 87906/1006307560-001/20210726		Made in GERMANY	

- | | | | |
|---|-------------------------------------|---|---|
| 1 | Type designation | 5 | Enclosure class/fan impeller speed/weight |
| 2 | Voltage/current/frequency | 6 | Insulation class |
| 3 | Input power | 7 | Article number/production number/manufacturing date |
| 4 | Max. temperature of transported air | 8 | Certifications |

Table 13 Type key

DVS	500	D4
Motor type		
E2	2 poled/controllable by frequency converter/1 phased	
E4	4 poled/controllable by frequency converter/1 phased	
E6	6 poled/controllable by frequency converter/1 phased	
DV	4 poled voltage controllable/3 phased	
DS	6 poled voltage controllable/3 phased	
EZ	2 poled voltage controllable/1 phased	
EV	4 poled voltage controllable/1 phased	
ES	6 poled voltage controllable/1 phased	
D4	4 poled/controllable by frequency converter/3 phased	
D6	6 poled/controllable by frequency converter/3 phased	
Impeller size		
Fan type		
DVS(l)	Roof fan - vertical discharge - standard - (insulated)	
DVN(l)	Roof fan - vertical discharge - high temperature - (insulated)	
DVC(l)-S	Roof fan - vertical discharge - EC Motor - (insulated) - standard	
DVC(l)-P	Roof fan - vertical discharge - EC Motor - (insulated) - integrated pressure regulating unit	
DVC(l)-POC	Roof fan - vertical discharge - EC Motor - (insulated) - integrated pressure sensors and outside temperature compensation	
DHS	Roof fan - horizontal discharge - standard	
DHA	Roof fan - horizontal discharge - axial impeller	

7 Accessories

For details of the accessories, please check our online catalog or contact Systemair.

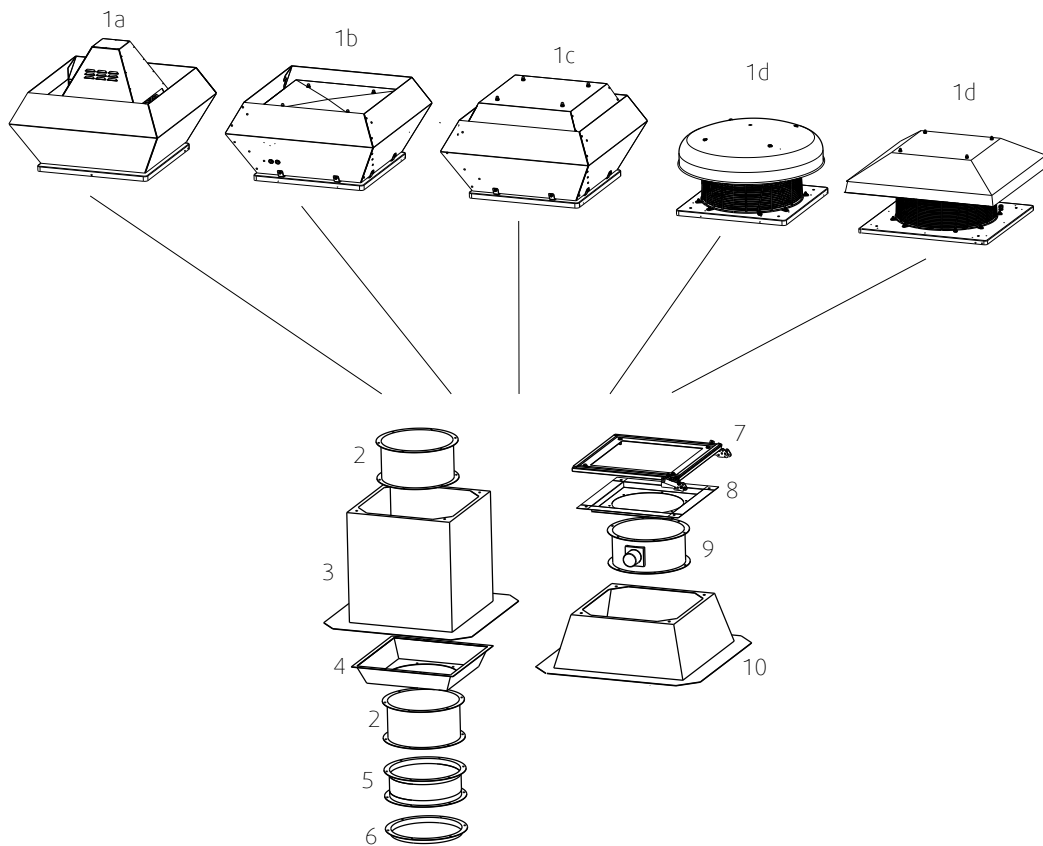

Table 14 Accessories

1a	DVN, DVNI	Roof fan - vertical discharge - high temperature - (insulated)			
1b	DVS/DVSI	Roof fan - vertical discharge - standard - (insulated)			
1c	DVC/DVCI	Roof fan - vertical discharge - ec motor - (insulated)			
1d	DHS	Roof fan - horizontal discharge - standard size 190 to 500 → round cap size 560 to 710 → squared cap			
2	VKS (ii)	Back draft damper	7	FTG (iii)	Tilting device
3	SSD (i)	Socket silencer	8	TDA	Adapter framework
4	ASK	Inflow box SSD	9	VKM (ii)	Back draft damper (motor driven)
5	ASS	Flexible connection	10	FDS (i)	Flat roof socket
6	ASF	Inlet flange			



Note:

- i. Size 190–450: If the degree of inclination is higher than 15°, a SSS (Slanting socket silencer) or a SDS (Slanting roof socket) has to be used.
Size 499–630: If the degree of inclination is higher than 10°, a SSS (Slanting socket silencer) or a SDS (Slanting roof socket) has to be used.
- ii. Do not install a VKS (self-actuating back draft damper) for roof fans (e.g. P version, POC version) which are controlled by sensors in the duct system. In this case, you must use a VKM (motor-driven back draft damper).
- iii. See chapter 8.3 *Assembly tilting device (FTG)*, page 14

8 Installation

Safety information

- ◆ Observe 2 *Important safety information*, page 1
- ◆ Use installation material with fire resistance classes that meet temperature requirements.
- ◆ Provide contact and intake protection and ensure safety distances according to DIN EN ISO13857 and DIN 24167-1.
- ◆ To reduce transmission of vibration to the duct system, we recommend flexible connections from our accessory range, see chapter Accessories.

Preconditions

- ◆ Ensure that the fan and all its components are undamaged.
- ◆ Fit the fans in such a way that there is sufficient access for installation, troubleshooting, maintenance and repair.
- ◆ Protect against dust and moisture when installing.
- ◆ Ensure that the information on the name plates (fan and motor) matches up with the operating conditions.

8.1 Installation of the ventilation system

Leaking roof due to wrong installation.

- ◆ The roof seal (e.g. plastic or bitumen foil) has to be pulled and fixed under the base plate of the roof fan, see below picture.

Leaking duct system.

- ◆ When installing the roof fan and accessories all mounting surfaces have to be sealed air tight.

Condensate formation due to thermal bridge.

1. Check if the fan and accessories form a thermal bridge.
2. Insulate the fan and accessories with vinyl rubber (e.g. Armaflex) in sufficient thickness.

- 1 Base plate of the roof fan
- 2 SSS Slanting socket silencer
- 3 Roof seal e.g. plastic or bitumen foil
- 4 Isolation
- 5 Roof construction

Damage to the bearings or other parts of the fan can occur.

- ◆ Do not place a duct bend directly before or after the fan!
- ◆ Ensure a smooth and constant air flow to the device.
 - Rectangular duct system: **D** = Hydraulic diameter
 - Round duct system: **D** = Nominal diameter

The below installation diagram is an example.

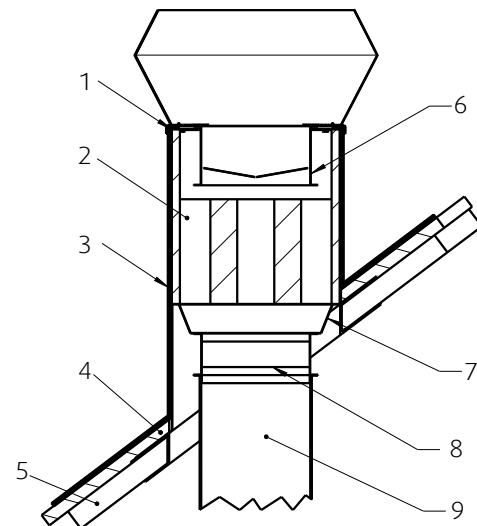

- 6 VKS/VKM Back draft damper
- 7 Has to be realized on-site
- 8 ASS Flexible connection
- 9 Duct system

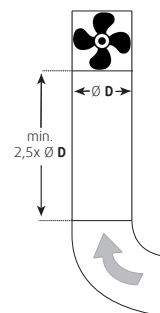

8.1.1 DVC-P measuring tubes

The following illustrations show the schematic installation of the measuring tubes.

Size
190-225

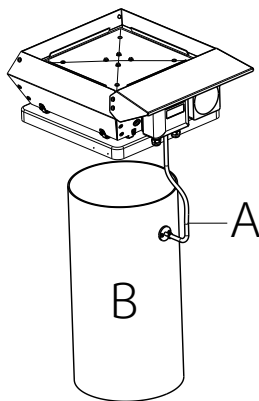

- A Measuring tubes
- B Duct system

Controller input
- Duct system
+ Atmosphere

Size
315-710

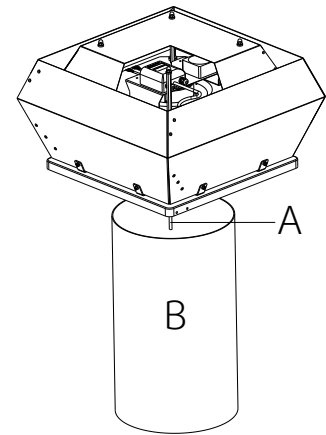

8.2 Assembly/Disassembly impeller – Internal rotor motor

If an external rotor motor is used, the motor and impeller can't be separated.

Damage to the motor and impeller.

The ball bearing of the motor and the balanced impeller may be damaged by forceful impacts.

- ◆ Attach the impeller and/or the shaft extension to the shaft or the rotor without forceful impacts.
- ◆ **Do not separate the impeller and the hub. They were balanced as one unit by Systemair.**



Note:

The hub can be heated for easier assembly and disassembly, for example with a hot-air blower.

- Precondition for assembly: the wedge is in the intended groove.
- Tools: hexagon socket wrench and suitable tool for removal, torque wrench for the taper clamping bush.

- 1 Motor
- 2 Motor shaft
- 3 Sleeve (not available at every fan)
- 4 Shaft extension (not available at every fan)
- 5 Hexagon socket screw
- 6 Impeller
- 7 Steel hub
- 8 Aluminium hub

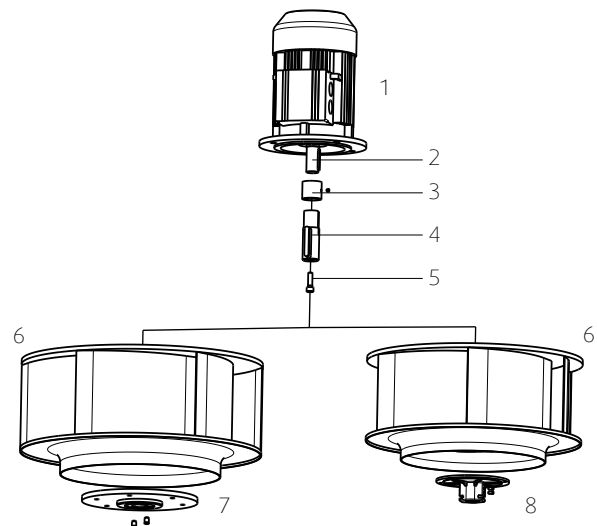

The hub is shown without impeller due to better lucidity.

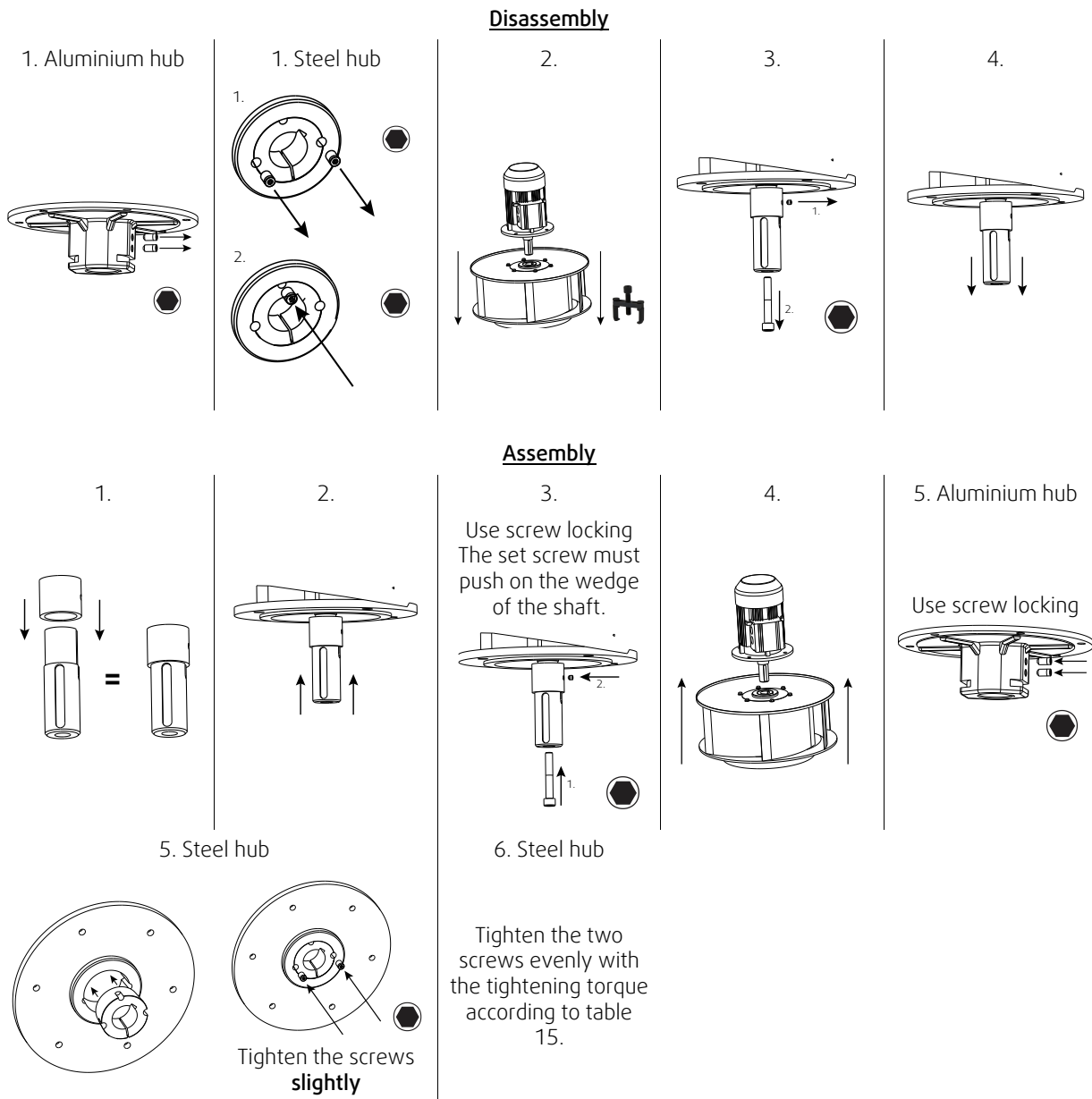

Table 15 Tightening torques for various types of bush

Type of bush	1008	1108	1210	1215	1310	1610	1615	2012	2517	3020
Tightening torque [Nm]	5.7	5.7	20	20	20	20	20	31	49	92

8.3 Assembly tilting device (FTG)

Danger of injury by tilting the fan during installation.

- ◆ The tilting device must be secured in the opened state by screws in the designated hole against unintentional folding.

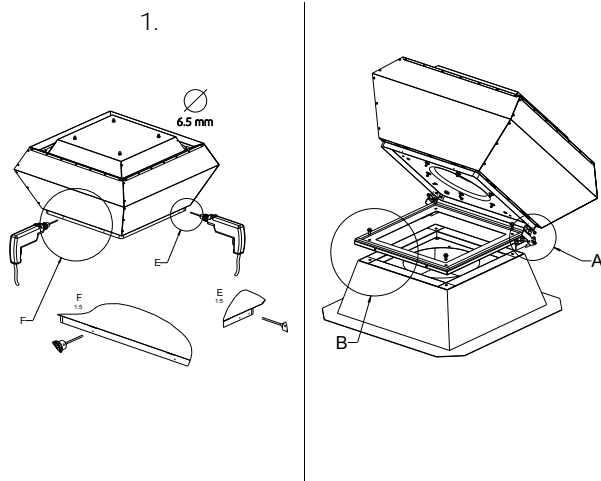

Leaking duct system.

- ◆ When installing the roof fan and accessories, all mounting surfaces have to be sealed air tight.

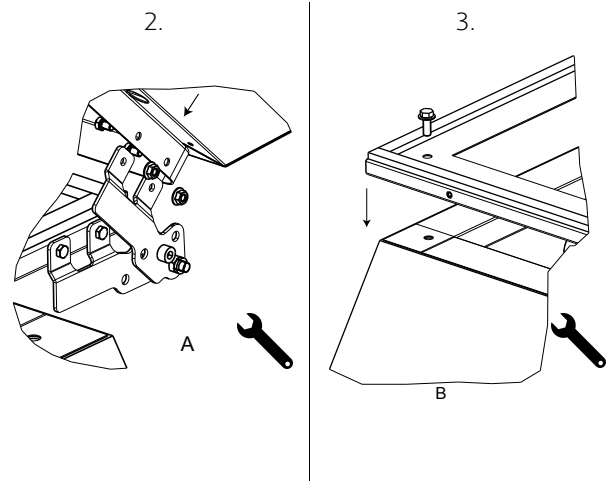

9 Electrical connection

Safety information

- ◆ Observe *2 Important safety information*, page 1
- ◆ Prevent the ingress of water into the connection box.

Connection

- ◆ Check if the data on the nameplate matches the connection data.
- ◆ Complete the electrical connection according to the circuit diagram.
- ◆ Fans with EC- motors must be switched on/off via the control input.
- ◆ Connect the cable end in a dry environment.
- ◆ Install a circuit breaker in the permanent electrical installation, with a contact opening of at least 3 mm at each pole.

Protective grounding wire

The protective grounding must have a cross-section equal to or greater than that of the phase conductor.

Residual current circuit breaker

All-current-sensitive residual current circuit breakers are required for use in alternating-current systems with 50/60 Hz, in combination with electronic devices such as EC motors, frequency converters or uninterruptible power supplies (UPS).

9.1 Electrical connection accessories

The following wiring diagrams show the electrical connections between accessories and fans (with EC motor) or frequency converters (e.g. FRQ, FRQS, FXDM) which can be controlled with a 0–10V signal. If you are not sure if your fan is equipped with an EC- motor please see chapter 6 *Name plate and type key*, page 9.

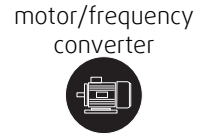

All fans with EC motors are equipped with a pre-wired potentiometer (0–10V).

- ◆ The potentiometer must be disconnected if the fan should be controlled by other accessories via 0–10V (e.g. accessories below).

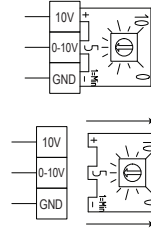

Wire- colours of motors with carried out cables: +10V = red 0..10V/PWM = yellow GND = blue

Control via 0–10V signal

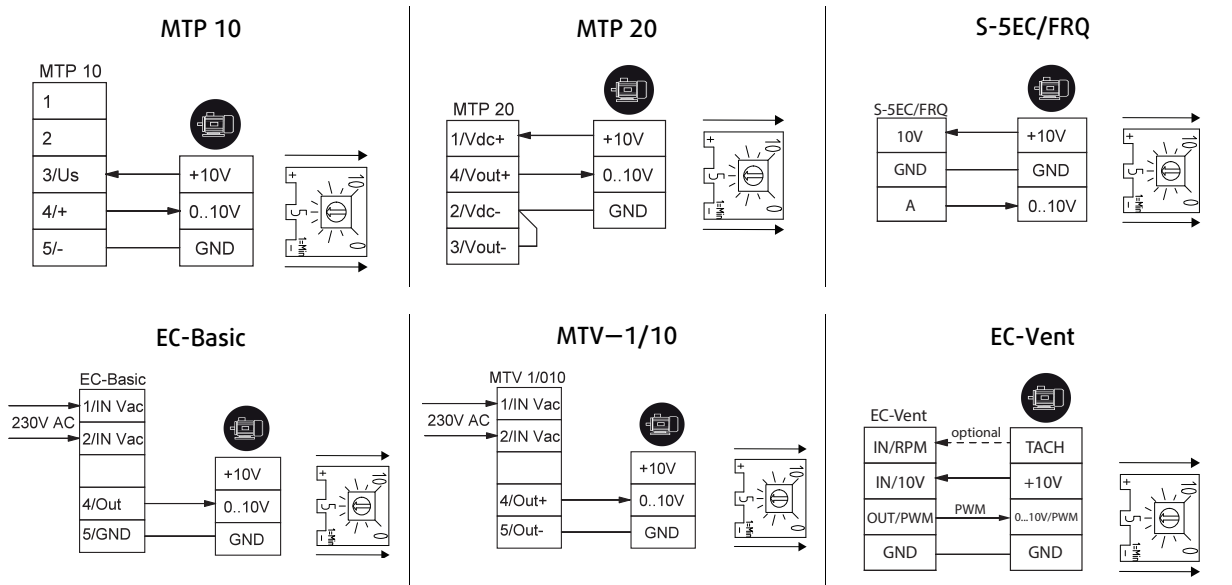

Control via switching on / off

The following fans are equipped with a DIN1 connection:

DVC(I) 560...	DVC(I) 710...	DVN(I) 500EC...	—	—
DVC(I) 630...	DVN(I) 450EC-K...	DVN(I) 560EC...	—	—

Din1: enable electronics

- enable: pin open or voltage 5–50 V DC
- disable: bridge to GND

CO2RT-R(-D)

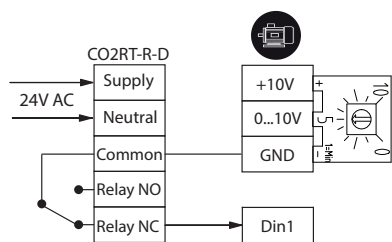

IR24-P

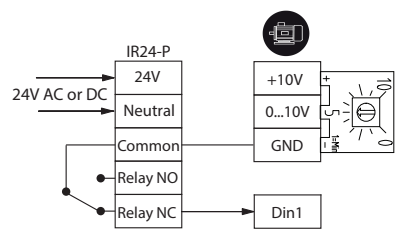

9.2 Protecting the motor



Note:

In fans equipped with an EC motor, there is no additional motor protection needed. The motor protection is integrated in the electronics of the motor.

Damage to motor due to overcurrent, overload or short circuit.

- ◆ Lead-out temperature monitors must be integrated in the control circuit in such a way that, if a fault occurs, the motor cannot switch on again automatically after it has cooled down.
- ◆ Motor lines and temperature monitor lines should be laid separately on principle.
- ◆ Without thermal protection: Use a motor protection switch!

9.3 Variable-speed fans

Resonant frequencies may result increased vibration in certain speed ranges. These vibrations may destroy components.

- ◆ Only operate the fan outside these speed ranges.
- ◆ Pass through these speed ranges so quickly that any vibration cannot exceed the admissible resonant frequency values.
- ◆ Observe the operating instructions of the frequency converter.

Damage as a result of incorrect commissioning of the frequency converter.

- ◆ Install the fan and frequency converter as near as possible to one another.
- ◆ Use shielded cables.
- ◆ All components (fan, frequency converter and motor) must be grounded.
- ◆ Avoid running the fan via the frequency converter below 10 Hz.
- ◆ Heating of the motor due to use of a variable frequency drive must be checked in the application by the customer.
- ◆ Never exceed the maximum impeller rotation speed indicated on the name plate of the fan.
- ◆ In any case Systemair recommends an all-pole sine filter if the fan is operated with a frequency converter.
 - ◆ For the following fans an all-pole sine filter is mandatory to avoid damages:
DVS, DVSI, DHS, DVC, DVCI

10 Commissioning

Warranty claims can only be made if commissioning work is carried out correctly and written evidence thereof is provided.

Safety information

- ◆ Observe *2 Important safety information*, page 1

Preconditions

- | | |
|--|---|
| <ul style="list-style-type: none"> ◆ Installation and electrical connection have been correctly performed. ◆ Before switching the fan on, check for externally visible damage and ensure that the protective equipment functions properly. | <ul style="list-style-type: none"> ◆ Inlet and outlet are free. ◆ Cable glands are tight. ◆ Safety devices have been fitted. |
|--|---|

Commissioning of speed-controlled fans

Check the fan for vibrations at all normal operation speeds during commissioning. Determine and evaluate vibrations on the housing and bearing areas in accordance with DIN ISO 14694 depending on motor power and positioning.

Measurable vibration velocities depend e.g. on following factors:

- positioning
- bottom section/foundation state
- flow conditions

The working point of the fan, as well as used external devices and accessories, also influence the running characteristics.

Tests

Do the tests requested in the commissioning report (16 *Commissioning Report*, page 20)

11 Operation

Safety information

- ◆ Observe 2 *Important safety information*, page 1

12 Troubleshooting/maintenance/repair

Safety information

- ◆ Observe 2 *Important safety information*, page 1

12.1 Troubleshooting

Table 16 Troubleshooting

Problem	Possible causes	Remedy
Fan does not reach nominal speed	Defective motor winding	Contact Systemair
	Control units (if used) such as frequency converter or transformer are set incorrectly.	Correct the settings of the control units.
	Mechanical blockage	Remove the blockage.
Fan does not run smoothly	Impeller imbalance	Rebalancing by a specialist company if possible, otherwise contact Systemair.
	Soiling on the impeller	Clean carefully, rebalance
	Material decomposition on the impeller due to aggressive material conveyed.	Contact Systemair
	Impeller rotates in wrong direction.	Change direction of rotation (swap two phases in case of a 3-phase motor). Contact Systemair
	Deformation of impeller due to excessive temperature.	Ensure that the temperature does not exceed the certified value/Install new impeller.
	Vibrations, oscillations	Check the installation of the fan/check the duct system, see 8 <i>Installation</i> , page 11.
Fan operation in resonant frequency range	Consider chapter 9.3 <i>Variable-speed fans</i> , page 16	

Troubleshooting cont'd

Air output of fan too low	Impeller rotates in wrong direction.	Change direction of rotation (swap two phases in case of a 3- phase motor).
	Wrong wiring configuration (e.g. Y instead of Delta).	Check and possibly correct the wiring configuration.
	Pressure losses too high.	Optimize the line routing.
	Flow regulators not or only partly open.	Check opening position on site.
	Intake or pressure ducts are blocked.	Remove the blockage.
	If the heat build-up in EC motors is too high, the power is throttled to protect the electronics or to prevent a shutdown. As soon as the temperature comes back to a normal value, the motor returns to adjusted speed. <i>(Valid for fans driven by EC Motors with "derating function" only)</i>	Check ambient temperature. Improve cooling.
Grinding sounds when starting or operating the fan	Check if the duct connections of the fan are strained.	Loosen the duct connections and realign it.
Thermal contacts/resistors have triggered	Impeller rotates in wrong direction.	Change direction of rotation if possible, otherwise contact Systemair.
	Missing phase	In case of a 3 phase standard motor (not EC), check if all 3 phase are present.
	Motor overheated	Check the cooling impeller (if used), measure the motor winding (if possible) / contact Systemair.
	Capacitor (if used) not or not correctly connected.	Connect the capacitor correctly.
	Motor blocked	Contact Systemair
Motor does not rotate	Faulty supply voltage	Check the supply voltage, re-establish the voltage supply.
	Faulty connection	Disconnect from the power supply, correct the connection, see circuit diagram.
	Temperature monitor has responded.	Allow the motor to cool down, find and resolve the cause of the fault.
Electronics/motor overheated	Insufficient cooling	Improve cooling.
	Overloaded motor	Check if the correct fan is used for your application.
	Ambient temperature too high	Check if the correct fan is used for your application.

**Note:**

For all other damage/defects, please contact Systemair. Defective safety-relevant fans (for Ex and smoke extraction applications) must be replaced completely.

12.2 Maintenance

Warranty claims can only be made if maintenance work is carried out correctly and written evidence thereof is provided.

We recommend regular maintenance intervals to ensure continuous fan operation. These maintenance intervals are specified in the “Activities” table below. In addition, the operator must carry out follow-up activities such as cleaning, replacing defective components or other corrective measures. For traceability reasons, a maintenance plan must be created which documents the work carried out. This must be created by the operator. If the operating conditions are "extreme", the maintenance intervals must be reduced so that maintenance is carried out more frequently. Examples of extreme operating conditions:

- Kitchen exhaust fans
- Durable ambient temperature > 30 °C or < -10 °C, or temperature fluctuations > 20 K

Table 17 Activities

Activity	Normal operating conditions		Extreme operating conditions	
	Every six months	Annually	Quarterly	Every six months
Check the fan and its components for visible damage, corrosion and contamination.		X		X
Check the impeller for damage and imbalance.		X		X
Check the condensate drain is working correctly.		X	X	
Clean the fan/ventilation system (see 13 <i>Cleaning</i> , page 20).	X		X	
Check the screwed connections for damages/defects and check that they are firmly seated.		X	See normal operating conditions	
Check the fan intake is free from contamination.		X		X
Check that the fan and its components are being used correctly.	X		See normal operating conditions	
Check the current consumption and compare this with the rated data.		X		X
Check the vibration dampers (if used) are working correctly and check for visible damage and corrosion.		X	See normal operating conditions	
Check the electrical and mechanical protective equipment is working correctly.		X	See normal operating conditions	
Check the fan’s rating plate is legible.		X		X
Check the connection clamps and screwed cable connections for damage/defects, and check that they are firmly seated.		X	See normal operating conditions	
Check the flexible connectors for damage.	X		See normal operating conditions	

Spare parts

- ◆ Use original spare parts from Systemair only.
- ◆ When ordering spare parts, please specify the serial number of the fan. This can be found on the name plate.

13 Cleaning

Safety information

- ◆ Observe 2 Important safety information, page 1

Procedure

Keeping the fan clean extends its service life.

- Install a filter monitor.
- Change the filters of the ventilation system.
- Do not use steel brushes or sharp-edged objects.
- Do not use a high-pressure cleaner (steam jet cleaner) under any circumstances.
- Do not bend the fan blades when cleaning.
- When cleaning the impeller, pay attention to balance weights that have been positioned
- Keep the airways of the fan clear and clean them if necessary with a brush.

14 Deinstallation/dismantling

Deinstall and dismantle the fan in reverse order of installation and electrical connection.

15 Disposal

- ◆ Ensure material is recycled. Observe national regulations.
- ◆ The device and the transport packaging are predominantly made from recyclable raw materials.
- ◆ Disassemble the fan into its components.
- ◆ Separate the parts according to:
 - reusable material
 - material groups to be disposed of (metal, plastics, electrical parts, etc.)

16 Commissioning Report

Warranty claims can only be made if commissioning work is carried out correctly and written evidence thereof is provided.

Fan

Description: _____

Article no.: _____

Manufacturing order no.: _____

Installer

Company: _____

Contact person: _____

Company address: _____

Tel. no.: _____

Email: _____

Operator (Place of installation)

Company: _____

Contact person: _____

Company address: _____

Tel. no.: _____

Email: _____

Type of connection

Directly to mains

Yes

No

0-10 V signal (EC motor)

via contactor control

Transformer

Frequency converter	<input type="checkbox"/>	<input type="checkbox"/>
Sinus filter	<input type="checkbox"/>	<input type="checkbox"/>
Shielded cables	<input type="checkbox"/>	<input type="checkbox"/>

Motor protection	Yes	No
Motor protection switch or motor protection relay	<input type="checkbox"/>	<input type="checkbox"/>
PTC resistor	<input type="checkbox"/>	<input type="checkbox"/>
Resistance value [Ω]:		
Thermal contact	<input type="checkbox"/>	<input type="checkbox"/>
Electrical motor protection	<input type="checkbox"/>	<input type="checkbox"/>
Others:		

Functional check	Yes	No
Impeller easily rotatable (by hand)	<input type="checkbox"/>	<input type="checkbox"/>
Rotation direction acc. to directional arrow	<input type="checkbox"/>	<input type="checkbox"/>
Smooth running without unusual noise/ vibrations	<input type="checkbox"/>	<input type="checkbox"/>

Nominal data - Fan (name plate on fan housing)

Voltage [V]:	Current [A]:
Frequency [Hz]:	Power [kW]:
Fan impeller speed [rpm]:	

Measured data at commissioning

Voltage [V]:	Temp. of transported air [$^{\circ}\text{C}$]:
Current L1 [A]*:	Fan impeller speed [rpm]:
Current L2 [A]:	<i>"Air volume", "Differential pressure" not necessary for jet fans</i>
Current L3 [A]:	Air volume [m^3/s]:
	Differential pressure [Pa]*:

*For single-phase fans, fill in line "Current L1 [A]"

* Δ - Pressure between suction-side and discharge of the fan

If an air flow measurement is not possible, this value can be calculated using the following formula:

_____	X	_____	=	_____	
Duct cross-section [m^2]		Flow speed [m/s] <small>Grille measurement acc. to VDI 2044</small>		Air volume [m^3/s]:	
				Yes	No
Commissioning of the fan successful?				<input type="checkbox"/>	<input type="checkbox"/>

Date, installer's signature

Date, operator's signature



Systemair GmbH
Seehöfer Str. 45
97944 Boxberg
Germany

Tel.: +49 (0)7930/9272-0
Fax: +49 (0)7930/9273-92

info@systemair.de
www.systemair.de