

SYSAQUA

Air Cooled Water Chillers

SYSAQUA.L (Cooling Only) / SYSAQUA.H (Heat Pump)

Models 20 to 125

Scroll Compressor



Refrigerant R410A



19.5 to 119.1kW



19.3 to 129.8kW



Key Points

- **R410A** refrigerant,
- Units are optimized for partial load operation,
- High ESEER and SEER,
- 2 compressors fitted in tandem for all the range with two capacity steps on sizes 20 to 45 and three capacity steps on sizes 55 to 125, with an immediate return on investment versus the inverter units,
- **Low noise version supplied as standard**, extra low noise version for the S units,
- "Night Mode" for energy savings and even more reduced noise level in night operation,
- Water law is standard for energy savings,
- Refrigerant circuit is completely closed in a separate compartment in order to reduce noise level (sizes 20 to 40),
- Great accessibility to internal components for service operations,
- New display on external panel allowing the complete control of the unit,
- Wide operating limits,
- High temperature operation up to 50 °C,
- Operation in heat pump mode down to external temperature of -17 °C,
- Fan speed control for low ambient operation in cooling mode down to -10 °C,
- ModBus interface available (reading/writing),
- Phase sequence monitor supplied as standard,
- User-friendly controller that allows to reduce the need of an external water tank in most of comfort air conditioning installations,
- Control logic on return or leaving water temperature,
- In cooling mode, 3.5 litres of buffer volume per kW are recommended,
- New technology "smart deice" standard for **SYSAQUA.H** units to ensure a constant temperature out of water even at very low temperatures
- Double water set point,
- Water filter (not fitted) and water flow switch (factory fitted) are supplied as standard,
- "Plug and play" hydraulic kit is standard on sizes 20 to 40 and optional on sizes 45 to 125,
- Automatic air vent,
- Victaulic connection on internal components ensuring a perfect sealing and facilitating service operations,
- Double 3/8" valve on water pipes for pressure measurement,
- Small footprint, allowing shipping and handling costs to be saved, units find easily a place to be installed.

SYSAQUA

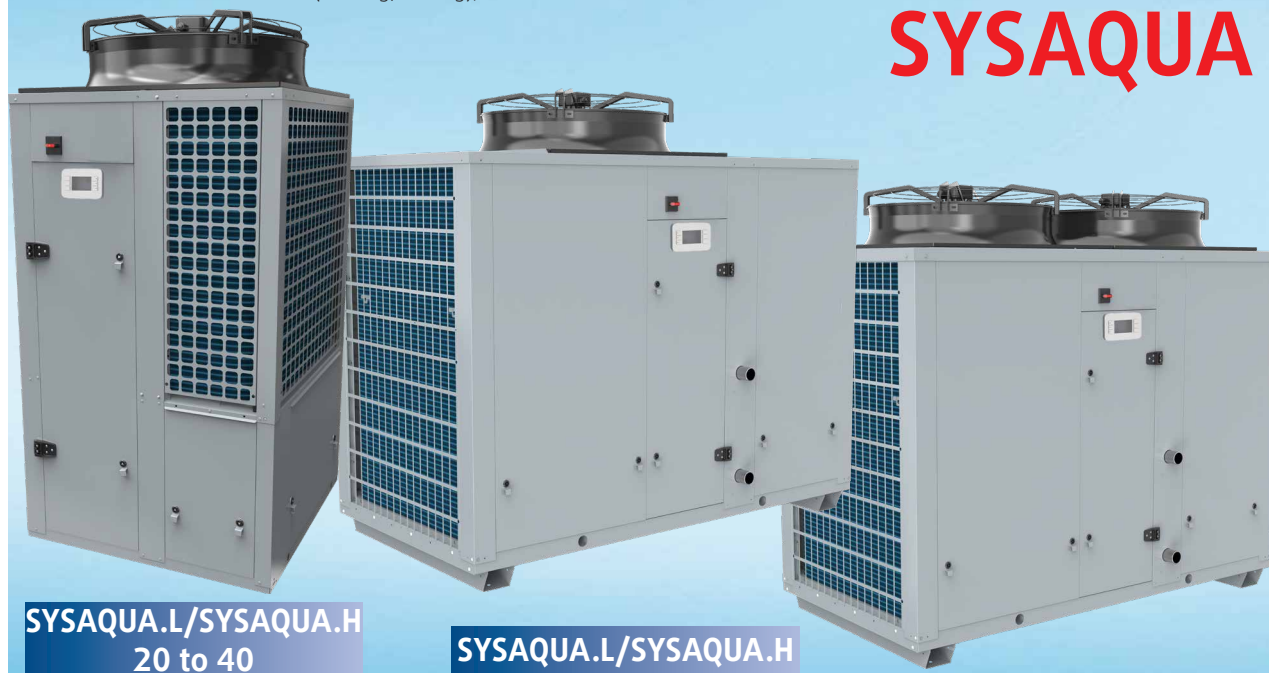

SYSAQUA.L/SYSAQUA.H
20 to 40

SYSAQUA.L/SYSAQUA.H
45 to 55

SYSAQUA.L/SYSAQUA.H
65 to 125

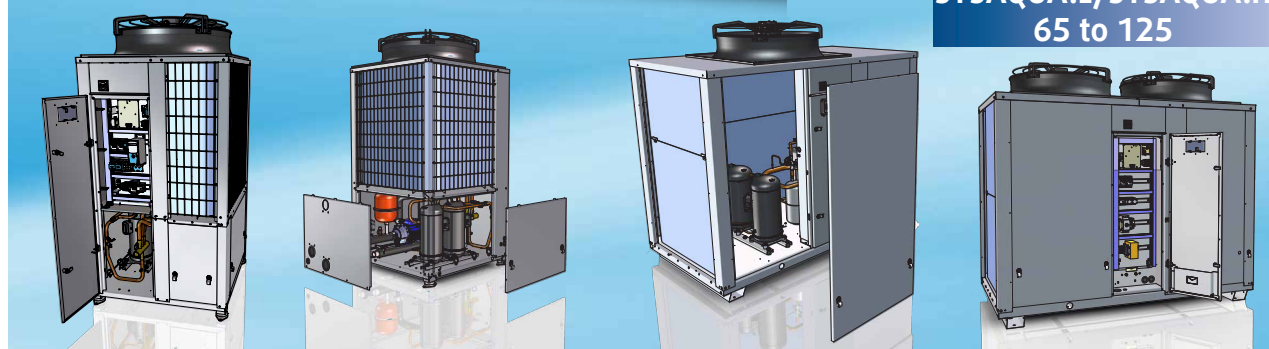

Specifications

General

The new **SYSAQUA.L/SYSAQUA.H 20 to 125** have been designed and optimized to operate with R410A refrigerant fluid. They are of single refrigerant circuit type.

They are available in **cooling only (SYSAQUA.L)** and **heat pump (SYSAQUA.H)** versions.

Each versions consists of **12 sizes (20, 25, 30, 35, 40, 45, 55, 65, 75, 90, 105 & 125)** and covers a nominal cooling capacity range from **19.3 to 129.8 kW** and a nominal heating capacity range from **19.5 to 119.1 kW**.

All units are equipped with **two scroll compressors fitted in tandem** for adapting to partial system loads.

The general operation status of the machine is continuously under the control of an **IHM controller**.

The **SYSAQUA.L** and **SYSAQUA.H units can operate without water tank**, thanks to the IHM controller that implements an **auto-adaptative control logic** ensuring a total protection of the compressors at different load or water volume conditions.

The minimum water volume requested in cooling mode is **3.5L/kW** for application air conditioning and **10L/kW** for application process.

In heating mode, **12.5L/kW** are recommended in order to guarantee homogeneous temperatures during the defrosting cycles (comfort and energy savings).

A **fan speed controller** can be also supplied as factory-fitted option to authorize the unit to operate in cooling mode at low ambient temperature.

SYSAQUA.L and **SYSAQUA.H** units can be supplied in several versions:

- **STD (Standard) version** : Includes a low noise acoustical performance.
- **S (Extra low noise) version** : Obtained by the installation of acoustic box around compressors.
- **HPF version** : Increases the static pressure.

Cabinet and structure

The cabinet and structure of the unit are of heavy duty galvanized steel. All galvanized steel components are **individually painted** by a special painting process before the assembly of the unit.

This painting system performs a homogeneous protection to the corrosion. The painting is a polyester powder based type, coloured in **RAL 7040**.

The units **SYSAQUA.L/SYSAQUA.H** are suitable for outdoor installation, directly on the building roof or at the ground level.

Compressors

Each unit is equipped with two scroll compressors fitted on a rail and assembled together to form **tandem compressors**.

The compressors are then mounted on rubber pads in order to eliminate noise and vibration transmissions.

The compressor motors have a direct start-up. Each motor is cooled by the refrigerant gas and is equipped with an overload protection.

A **phase sequence monitor** is supplied as standard.

Evaporator

The evaporator is consisting of a stainless steel plate heat exchanger insulated with closed cell synthetic foam. It is protected by an **antifreeze electric heater** to ensure a good protection against freezing at low ambient temperature (-10 °C min.) when the unit is switched off.

Maximum working pressure is 10 bar at water side and 45 at refrigerant side.

Condenser

The condenser is a finned coil constructed with seamless copper tubes mechanically expanded into aluminium fins. The fins of **SYSAQUA.H** coils are made of aluminium with hydrophylic blue coating to facilitate water droplets drain.

The condenser is largely dimensioned in order to optimize performance and defrosting cycles.

The condenser can be equipped, as optional, a protective grille to prevent shocks.

Condenser fans and motors

Each unit has one or two axial fan, with 2 speeds. According to the version, the fan is cabled in order to have high speed (700 to 900 rpm) for Standard version and low speed (530 to 680 rpm) to reduce the sound level for S version.

The fan motor has IP54 grade and is equipped with a thermal overload protection.

A pressostatic type fan speed controller can be delivered as factory-fitted option. It allows the unit to operate in cooling mode at low ambient temperatures down to -10 °C minimum, because it regulates the fan speed in order to maintain the constant condensing temperature.

All fans are fitted with a protective grille on top.

Refrigerant circuit

All units have one refrigerant circuit consisting of : scroll tandem compressors, plate heat exchanger, thermostatic expansion valve, 4-way reverse cycle valve and liquid reservoir (heat pump version only), condenser coil, as well as safety and control devices such as high pressure switch, high/low pressure transducers and PED safety valve.

Inspection on refrigerant via a sight glass can be done during service operations, by removing an access panel, without disturbing the unit operating conditions.

A set of LP and HP gauges can be factory fitted as optional.

All refrigerant components are shown in the functional diagrams illustrated in the next pages, section "Refrigerant flow diagrams".

Hydraulic circuit

Thanks to the design flexibility on the hydraulic circuit, all the units can be configured in several ways :

- **BASIC unit** : Unit without pump, the hydraulic circuit contains the following components : supplied loose water filter, mounted water flow switch, water safety valve, automatic air vent, optional field-installed in/out 3/8" water valves. All water piping is covered with thermal insulation.
- **1P-SP** : One pump unit having the same equipment as BASIC unit + a pump with 150 kPa external static pressure. An air vent is provided for this configuration.
- **2P-SP** : Two pump unit (from size 45) having the same equipment as BASIC unit + 2 pumps with 150 kPa external static pressure. Each pump can be isolated and replaced with the aid of two valves. An air vent is also provided for this configuration.
- **"Variable Primary Flow"** is used to modulate the power of the hydraulic pump

The different components of hydraulic kit are interconnected by Victaulic couplings in order to facilitate maintenance operations.

The hydraulic connections are of male gas threaded type; for the connection diameters, please refer to the physical data tables on the next pages.

Specifications

Control panel

The units are fitted with an external control panel that displays the operating parameters and alarms.

The control panel is accessible from exterior without removing any parts, nor shutting down the unit, because it is placed on an external panel.

The **SYSAQUA.L/SYSAQUA.H** chillers are equipped with a microprocessor based control with a new **IHM** logic that implements an intelligent control **with anticipation of needs**, either on entering water temperature, or on leaving water temperature.

The main features of this control system are :



- User-friendly : with only 6 buttons and a tree logic, it is possible to control the unit easily,
- Reliable : all indications on the display are visible in every weather conditions,
- Internal test procedure,
- Alarm visualization with a logging of the last 10 alarms,
- Remote ON/OFF switching,
- Compressor and pump working hour counter,
- Pressure transducers to control discharge and suction temperatures,
- Maximum discharge temperature control,
- Part load operating mode,
- Remote Cooling/Heating mode switching,
- Compatibility with BMS (RS485 ModBus RTU or BacNet MSTP protocol),
- Compressor operating limits stored in a flash memory.

Control and safety devices

Each unit is complete with the following safety and control devices :

Safety :

- ➔ Fan motor overload protection.
- ➔ Compressor motor overload protection.
- ➔ Water flow switch.

- ➔ Water filter (supplied loose).
- ➔ High pressure switch.
- ➔ High and low pressure transducers.
- ➔ Evaporator antifreeze electric heater.
- ➔ Crankcase heater.
- ➔ Safety valve on 45 bar refrigerated side.
- ➔ Safety valve on 3 bar water side.

Control :

- ➔ Entering water temperature sensor.
- ➔ Leaving water temperature sensor.
- ➔ Coil temperature sensor.
- ➔ Discharge temperature sensor.
- ➔ Air temperature sensor.
- ➔ Suction and discharge pressure transducers.
- ➔ Dry contact available to the client:
ON / OFF, SUMMER / WINTER, Day / Night.

Conformity with standards

All **SYSAQUA.L/SYSAQUA.H** units are in compliance with the following standards:

- ✓ Machine Directive : 2006/42/EC
- ✓ Low Voltage Directive : 2014/35/UE
- ✓ Electromagnetic Compatibility Directive : 2014/30/UE
- ✓ Pressure Equipment Directive : 2014/68/UE
- ✓ RoHs directive : 2011/65/EU

Factory-installed options

- ➔ Condenser protective grille.
- ➔ Reinforced acoustic insulation (XLN version).
- ➔ Coil with epoxy treatment.
- ➔ LP/HP gauges.
- ➔ Power supply without neutral kit.
- ➔ Lack of water pressure switch.
- ➔ 1-pump hydraulic kit (sizes 45 to 125).
- ➔ 2-pump hydraulic kit (sizes 45 to 125)
- ➔ Variable Primary Flow
 - ✓ double speed
 - ✓ capacity
 - ✓ constant outlet pressure
- ➔ Fan speed control kit (for operation with low ambient temperature down to -10 °C).
- ➔ Nordic Pack including a protection of the external coils and a heating wire in condensate tray.
- ➔ Electric heating

Field-installed accessories

- ➔ Anti-vibration rubber pads or spring damper.
- ➔ In/Out valve kit.

Models designation

SYSAQUA40 . H . 1P-SP . STD . SYS . AC . . + . CG . T

① ② ③ ④ ⑤ ⑥ ⑦ ⑧ ⑧

REP.	Description
① Size	SYSAQUA20 : size 20 SYSAQUA35 : size 35 SYSAQUA55 : size 55 SYSAQUA90 : size 90 SYSAQUA25 : size 25 SYSAQUA40 : size 40 SYSAQUA65 : size 65 SYSAQUA105 : size 105 SYSAQUA30 : size 30 SYSAQUA45 : size 45 SYSAQUA75 : size 75 SYSAQUA125 : size 125
② Version	L : Cooling only H : Heat pump
③ Hydraulic circuit	Empty: Without pump 2P-SP : Pack Double pump 1P-SP : Pack Single pump
④ Regulation	STD : Standard FSC : All seasons
⑤ Brand	SYS : Systemair
⑥ Fan type	AC : Standard fan AC motor HPF : High pressure fan
⑦ ERP	NoErp : not compatible Ecodesign
⑧ Option	CG : Outdoor coil protection grid SS : Soft Starter EPO : Finned coil treatment - epoxy NORD : Pack nordic WPS : Low water pressure sensor CC : Container transport S : Extra low noise V2 : Variable pump double speed AVS : Spring damper VC : Variable pump capacity AVM : rubber pads VP : Variable pump constant outlet pressure VI : Water isolation valves EH12 : Electric heating 12KW KM : Refrigerant gauge EH24 : Electric heating 24KW T : Buffer tank EH36 : Electric heating 36KW

Product Codes

Product codes	Description	Product codes	Description
372031	SYSAQUA25.H.1P-SP+WPS.AVM	372043	SYSAQUA65.H.1P-SP+WPS.AVM
372032	SYSAQUA25.H.1P-SP+WPS.AVM.T	372044	SYSAQUA65.H.1P-SP+WPS.AVM.T
372033	SYSAQUA30.H.1P-SP+WPS.AVM	372045	SYSAQUA75.H.1P-SP+WPS.AVM
372034	SYSAQUA30.H.1P-SP+WPS.AVM.T	372046	SYSAQUA75.H.1P-SP+WPS.AVM.T
372035	SYSAQUA35.H.1P-SP+WPS.AVM	372047	SYSAQUA90.H.1P-SP+WPS.AVM
372036	SYSAQUA35.H.1P-SP+WPS.AVM.T	372048	SYSAQUA90.H.1P-SP+WPS.AVM.T
372037	SYSAQUA40.H.1P-SP+WPS.AVM	372049	SYSAQUA105.H.1P-SP+WPS.AVM
372038	SYSAQUA40.H.1P-SP+WPS.AVM.T	372050	SYSAQUA105.H.1P-SP+WPS.AVM.T
372039	SYSAQUA45.H.1P-SP+WPS.AVM	372051	SYSAQUA125.H.1P-SP+WPS.AVM
372040	SYSAQUA45.H.1P-SP+WPS.AVM.T	372052	SYSAQUA125.H.1P-SP+WPS.AVM.T
372041	SYSAQUA55.H.1P-SP+WPS.AVM		
372042	SYSAQUA55.H.1P-SP+WPS.AVM.T		

Refrigerant Flow Diagram

Cooling only version - SYSAQUA.L 20 to 125

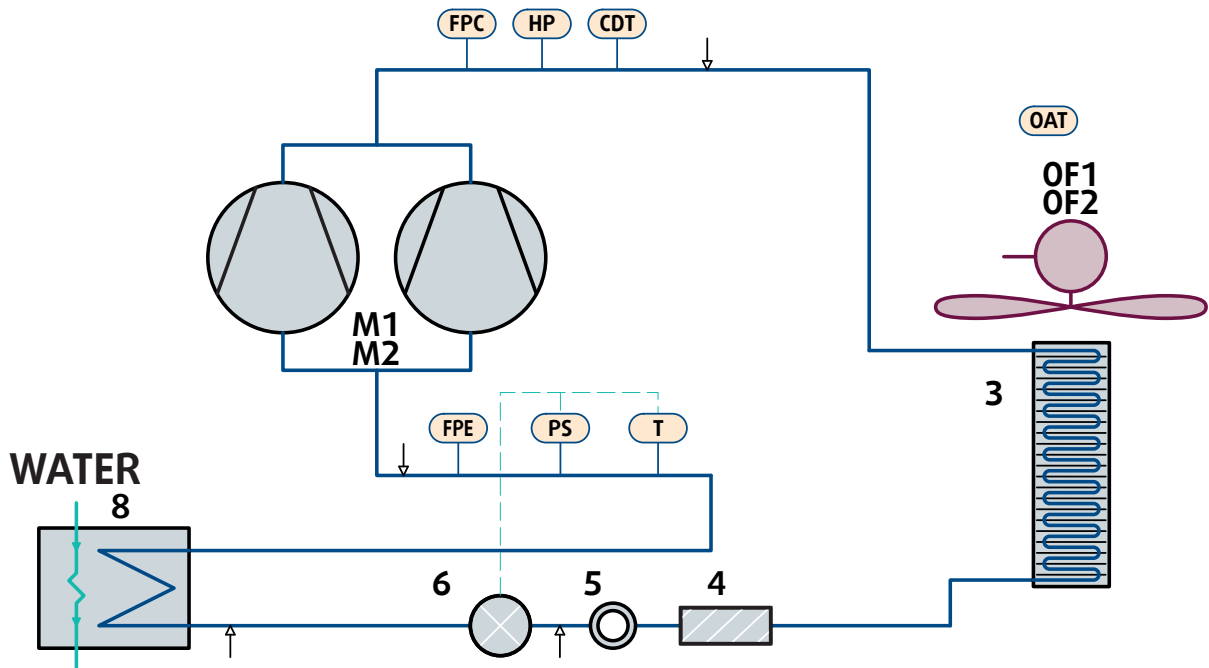

Heat pump version - SYSAQUA.H 20 to 125

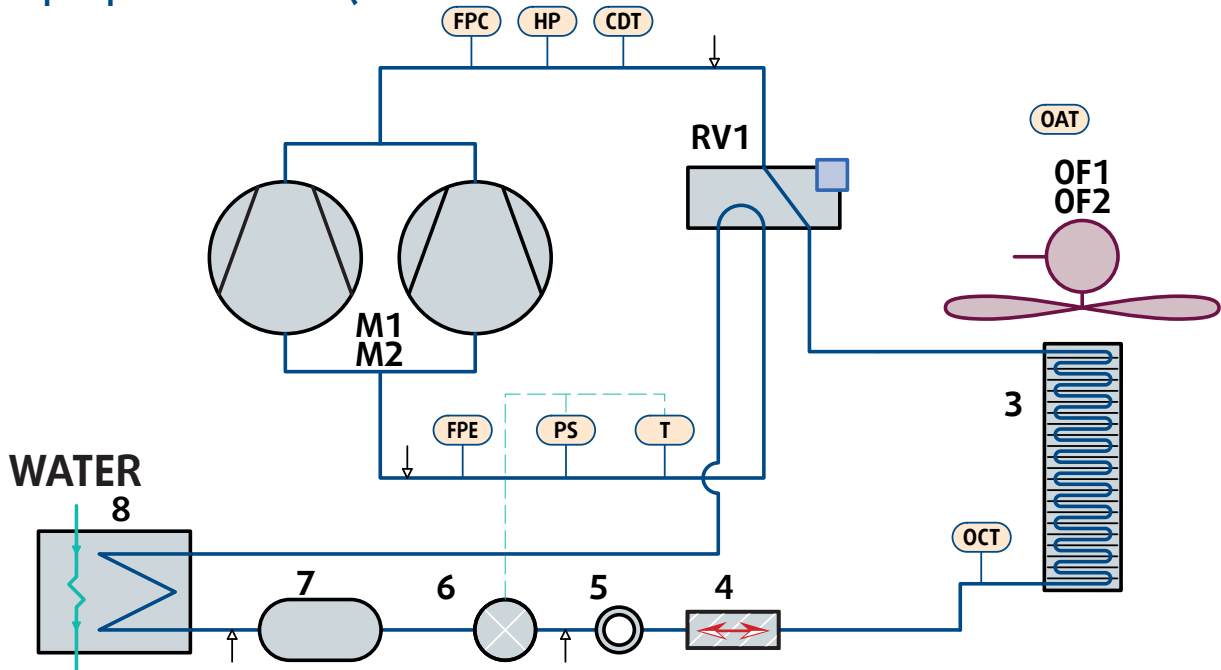

components	
M1/M2	Tandem scroll compressors
RV1	Cycle reversal valve
OF1/OF2	Outdoor fan motor
3	Air cooled condenser
4	Filter drier
5	Sight glass
6	Thermostatic expansion valve
7	Liquid reservoir
8	Plate heat exchanger
↓	Pressure tapping point 5/16"

safety/control devices	
FPC	High pressure transducer
HP	High pressure switch
CDT	Discharge temperature sensor
FPE	Low pressure transducer
PS	Expansion valve pressure tap
T	Expansion valve bulb
OAT	Outdoor air temperature sensor
OCT	Condenser outlet temperature sensor
OCT1	Models 65 to 125
OCT2	Models 65 to 125

Hydraulic Circuit Diagram

Without pump version

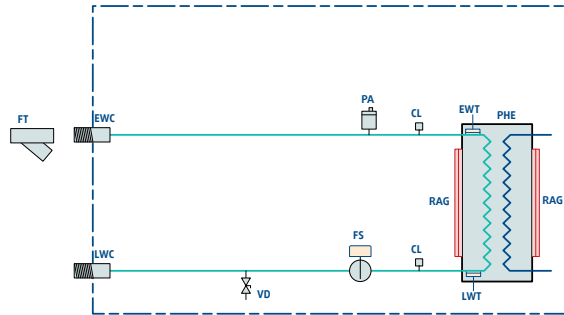

Recommended installation - Single pump version

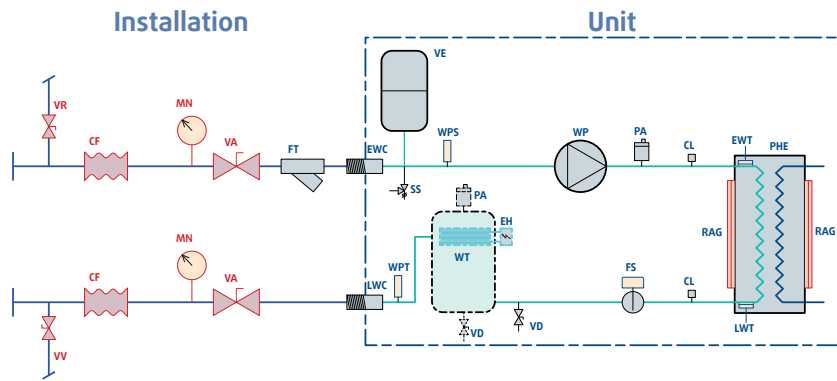

Recommended installation - Double pump version

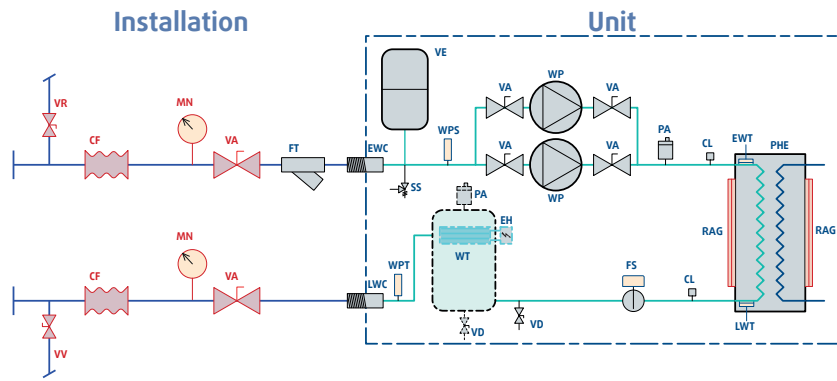

Recommended installation	
VA	Globe valve (option)
VV	Drain valve
CF	Connexion flexible
VR	Water charging valve
MN	Manometer

Hydraulic Circuit	
FT	Filter (supplied loose)
EWC/LWC	Inlet/Outlet gas male connection (20 to 40 : 1"1/2 - 45 to 75 : 2" - 90 to 125 : 2"1/2)
VE	Pressure expansion tank
WPS	Lack of water pressure switch (optional)
SS	Safety valve
WP	Pump
PA	Automatic air vent
CL	Pressure tap 3/8"
EWT	Inlet water temperature sensor
LWT	Outlet water temperature sensor
PHE	Plate heat exchanger
RAG	Antifreeze heater
FS	Flow switch
VD	Drain valve
WT	Buffer tank
EH	Electric heating (optional - 45 to 125)
WPT	Pressure transducer (optional)

Energy performance

Energy class

More efficient

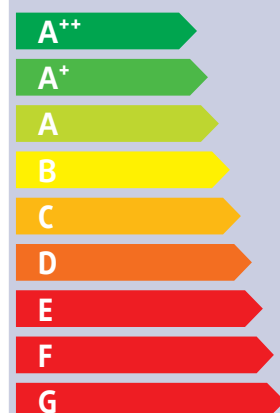

SYSAQUA.H	20	25	30	35	40
SCOP *	3.37	3.27	3.27	3.36	3.40
Class	A+	A+	A+	A+	A+
SYSAQUA.H	45	55	65	75	
SCOP *	3.23	3.27	3.43	3.40	
Class	A+	A+	A+	A+	
SYSAQUA.H	90	105	125		
SCOP *	3.26	3.31	3.35		
Class	A+	A+	A+		

Seasonal space heating energy efficiency class according to the Delegated Regulation No. 811/2013 of the European Commission.

* According to EN14511-2013

Operating Limits

SYSAQUA.L/SYSAQUA.H in cooling mode

SYSAQUA.L/SYSAQUA.H models		20		25		30		35		40		45		55		
		Min.	Max.	Min.	Max.	Min.	Max.	Min.	Max.	Min.	Max.	Min.	Max.	Min.	Max.	
Water	Water outlet temperature * °C	-10	18	-10	18	-10	18	-10	18	-10	18	-10	18	-10	18	
	Water ΔT **	K	3	8	3	8	3	8	3	8	3	8	3	8	3	8
	Flow rate **	m ³ /h	2.7	5.8	2.7	7.2	3.0	8.0	3.8	10.2	4.1	11.0	5.0	13.7	5.8	15.5
Air temperature		°C See diagrams on next page														

SYSAQUA.L/SYSAQUA.H models		65		75		90		105		125		
		Min.	Max.	Min.	Max.	Min.	Max.	Min.	Max.	Min.	Max.	
Eau	Water outlet temperature * °C	-10	18	-10	18	-10	18	-10	18	-10	18	
	Water ΔT **	K	3	8	3	8	3	8	3	8	3	8
	Flow rate **	m ³ /h	7.0	18.7	8.0	21.3	9.6	25.5	11.0	29.3	13.1	34.8
Air temperature		°C See diagrams on next page										

* Below 5 °C, glycol is required.

** considered at nominal unit capacity

SYSAQUA.H in heating mode

SYSAQUA.H models		20		25		30		35		40		45		55		
		Min.	Max.	Min.	Max.	Min.	Max.	Min.	Max.	Min.	Max.	Min.	Max.	Min.	Max.	
Water	Water outlet temperature	°C														
	Water ΔT **	K	3	8	3	8	3	8	3	8	3	8	3	8	3	8
	Flow rate **	m ³ /h	2.7	5.8	2.7	7.2	3.0	8.0	3.8	10.2	4.1	11.0	5.0	13.7	5.8	15.5
Air temperature		°C See diagrams on next page														

SYSAQUA.H models		65		75		90		105		125		
		Min.	Max.	Min.	Max.	Min.	Max.	Min.	Max.	Min.	Max.	
Water	Water outlet temperature	°C										
	Water ΔT **	K	3	8	3	8	3	8	3	8	3	8
	Flow rate **	m ³ /h	7.0	18.7	8.0	21.3	9.6	25.5	11.0	29.3	13.1	34.8
Air temperature		°C See diagrams on next page										

** considered at nominal unit capacity

Operating Limits

SYSAQUA.L/SYSAQUA.H in cooling mode

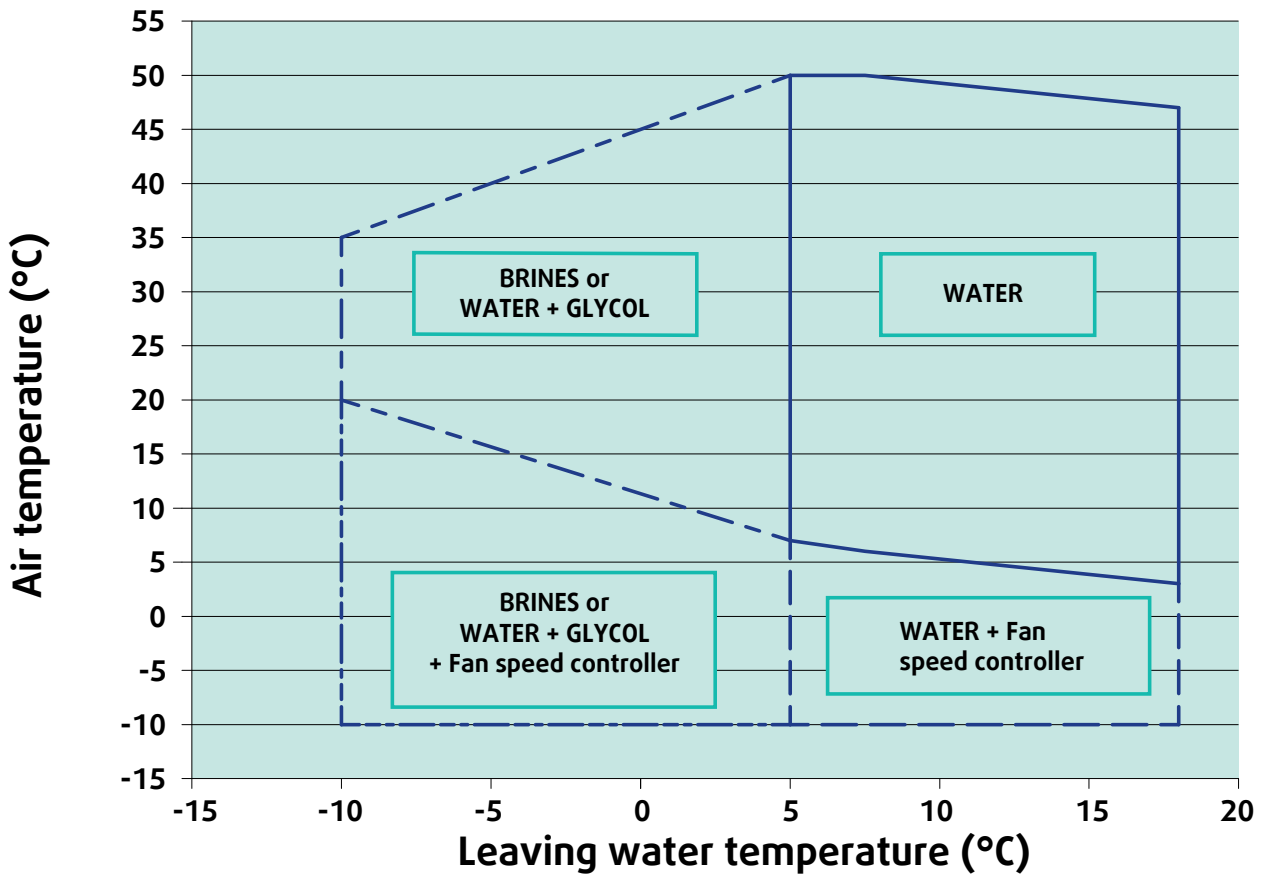

SYSAQUA.H in heating mode

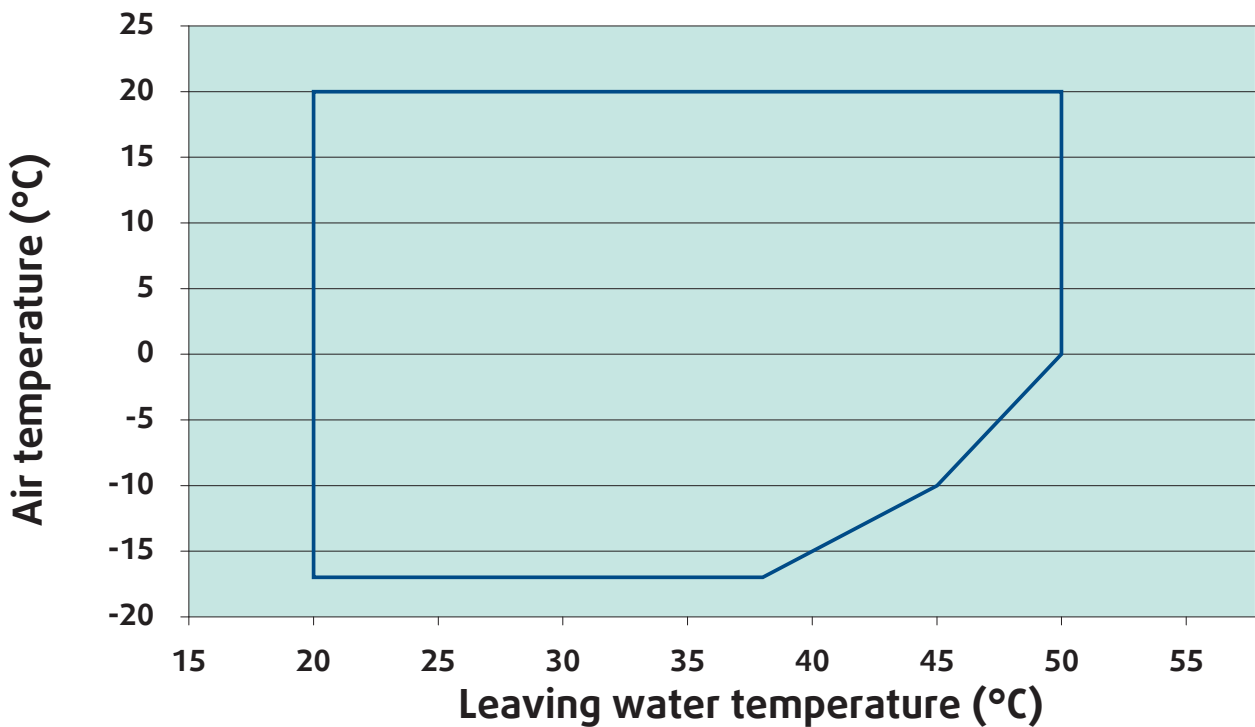

Correction Factors

Fouling factors - Evaporator

Fouling factor (m ² .°C/kW)	Capacity	Power input
0.044	1.000	1.000
0.088	0.987	0.995
0.176	0.964	0.985
0.352	0.915	0.962

Fouling factors - Condenser

Fouling factor (m ² .°C/kW)	Capacity	Power input
0.044	1.000	1.000
0.088	0.987	1.023
0.176	0.955	1.068
0.352	0.910	1.135

Altitude factors

Altitude (m)	Capacity	Power input
0	1.000	1.000
600	0.987	1.010
1200	0.973	1.020
1800	0.958	1.030
2400	0.943	1.040

Correction factors - Ethylene glycol

% glycol	Freezing point (°C)	Capacity	Power input	Water flow	Pressure drop
0	0	1.00	1.00	1.00	1.00
10	-4	0.995	0.998	1.015	1.070
20	-10	0.985	0.995	1.050	1.160
30	-17	0.970	0.985	1.085	1.235
45	-30	0.949	0.977	1.169	1.368

Warning !

Ethylene glycol is toxic to the environment. Moreover, it is not suitable for heating with domestic hot water production by simple exchange.

Correction factors - Propylene glycol

% glycol	Freezing point (°C)	Capacity	Power input	Water flow	Pressure drop
0	0	1.00	1.00	1.00	1.00
10	-3	0.991	0.994	1.005	1.112
20	-7	0.977	0.991	1.030	1.175
30	-13	0.945	0.975	1.067	1.290
45	-27	0.894	0.962	1.162	1.520

Physical Data - SYSAQUA.L STD

SYSAQUA - Cooling only version		20	25	30	35	40	45	
Cooling capacity	kW	19.3	24.7	27.1	38.2	40.9	49.8	
Power input	kW	6.1	7.7	9.0	12.2	13.4	16.7	
Total EER 100% (1)		3.16	3.21	3.01	3.13	3.05	2.98	
Energy class EER		A	A	B	A	B	B	
SEER (2)		4.59	4.45	4.23	4.42	4.21	4.12	
ηsc (2)		181	175	166	174	166	162	
Energy class SEER		A+	A	A	A	A	A	
Power supply		400V/3~+N/50Hz						
Startup type		Direct						
Maximum operating current	A	17.7	22.2	24.3	31.8	33.8	40.2	
Startup current (without Soft Starter)	A	52.7	63.7	77.3	118.3	119.3	133.2	
Startup current (with Soft Starter)	A	28.1	35.2	48.8	53.0	54.0	65.8	
REFRIGERANT								
Type		R410A						
Number of refrigerant circuit		1						
Charge	kg	8.4	8.4	8.4	9.1	9.2	14.5	
COMPRESSORS								
Number		2		2	2	2	2	
Type		Scroll						
Part load steps	%	0/50/100	0/50/100	0/50/100	0/50/100	0/50/100	0/50/100	
Crankcase heater	W	2 X 40	2 X 40	2 X 49	2 X 49	2 X 49 70	2 x 66	
EVAPORATOR								
Number		1	1	1	1	1	1	
Type		Plate						
Water flow	m ³ /h	3.31	4.25	4.64	6.59	7.02	8.57	
Water pressure drop	kPa	22	35	22	41	46	30	
Water volume	l	1.78	1.78	2.55	2.55	2.55	4.1	
Antifreeze heater	W	30	30	30	30	30	30	
COIL								
Number		1	1	1	1	1	1	
Frontal surface	m ²	2.40	2.40	2.40	2.80	2.80	4.20	
Number of rows		2	2	2	2	2	2	
FAN								
Number		1	1	1	1	1	1	
STD	Air flow	m ³ /h	9 000	13 000	13 000	16 000	16 000	22 500
	Rotational speed	tr/mn	900	900	900	650	650	790
	Power input each fan	W	620	940	940	930	930	1 650
HPF	Air flow	m ³ /h	/	14 000	14 000	14 000	14 000	21 000
	Rotational speed	tr/mn	/	870	870	870	870	890
	Power input each fan	W	/	1 950	1 950	1 950	1 950	1 950
	Static pressure	Pa	/	140	140	140	140	100
WATER CONNECTIONS								
Type		Male gas threaded						
Inlet diameter	pouces	1"1/2	1"1/2	1"1/2	1"1/2	1"1/2	2"	
Outlet diameter	pouces	1"1/2	1"1/2	1"1/2	1"1/2	1"1/2	2"	
BUFFER TANK (OPTION)								
Volume	L	100	100	100	100	100	300	
DIMENSIONS								
Length	mm	1 000	1 000	1 000	1 000	1 000	2 180	
Width	mm	1 000	1 000	1 000	1 000	1 000	1 160	
Height	STD	mm	1 983	1 983	1 983	1 983	1 986	
	HPF	mm	2 025	2 025	2 025	2 025	2 025	
WEIGHT								
Operating weight	kg	265	275	305	315	315	515	
ACOUSTICAL DATA								
Sound power level	dB(A)	75	75	75	76	76	80	
Sound pressure level (*)	dB(A)	42.8	42.8	42.8	43.8	43.8	47.8	

(*) Sound pressure levels calculated at 10 meters. Sound pressure levels refer to ISO standard 3744 with parallelepiped shape.

(1) According to EN14511-2013 (2) According to Eurovent

Physical Data - SYSAQUA.L STD

SYSAQUA - Cooling only version		55	65	75	90	105	125	
Cooling capacity	kW	56.9	69.7	75.8	97.0	112.7	129.8	
Power input	kW	18.8	22.1	24.2	32.5	38.6	44.3	
Total EER 100% (1)		3.03	3.15	3.13	2.98	2.92	2.93	
Energy class EER		B	A	A	C	B	C	
SEER (2)		4.12	4.41	4.32	4.23	4.12	4.24	
η _{sc} (2)		162	174	170	166	162	167	
Energy class SEER		A	A	A	A	A	A	
Power supply		400V/3~+N/50Hz						
Startup type		Direct						
Maximum operating current	A	44.2	59.4	64.4	77.9	86.0	102.0	
Startup current (without Soft Starter)	A	140.2	201.4	206.4	264.9	312.0	350.0	
Startup current (with Soft Starter)	A	72.8	101.0	106.0	127.3	145.8	182.6	
REFRIGERANT								
Type		R410A						
Number of refrigerant circuit		1						
Charge	kg	14.9	18.9	19.0	22.0	27.0	28.5	
COMPRESSORS								
Number		2	2	2	2	2	2	
Type		Scroll						
Part load steps	%	0/43/57/100	0/40/60/100	0/45/55/100	0/45/55/100	0/38/62/100	0/33/67/100	
Crankcase heater	W	2 x 66	2 x 66	2 x 66	66/82	66/95	66/95	
EVAPORATOR								
Number		1	1	1	1	1	1	
Type		Plate						
Water flow	m ³ /h	9.79	11.99	13.03	16.67	19.37	22.32	
Water pressure drop	kPa	40	31	37	29	38	50	
Water volume	l	4.1	6.1	6.1	10.8	10.8	10.8	
Antifreeze heater	W	30	2x30	2x30	2x30	2x30	2x30	
COIL								
Number		1	2	2	2	2	2	
Frontal surface	m ²	4.20	5.55	5.55	6.40	6.40	6.40	
Number of rows		2	2	2	2	3	3	
FAN								
Number		1	2	2	2	2	2	
STD	Air flow	m ³ /h	22 500	30 000	30 000	42 000	42 000	42 000
	Rotational speed	tr/mn	790	650	650	790	790	790
	Power input each fan	W	1 650	930	930	1 650	1 650	1 650
HPF	Air flow	m ³ /h	21 000	2 X 16000	2 X 16000	2 X 20000	2 X 20000	2 X 20000
	Rotational speed	tr/mn	890	870	870	890	890	890
	Power input each fan	W	1 950	1 950	1 950	1 950	1 950	1 950
	Static pressure	Pa	100	130	130	100	90	90
WATER CONNECTIONS								
Type		Male gas threaded						
Inlet diameter	pouces	2"	2"	2"	2"1/2	2"1/2	2"1/2	
Outlet diameter	pouces	2"	2"	2"	2"1/2	2"1/2	2"1/2	
BUFFER TANK (OPTION)								
Volume	L	300	300	300	300	300	300	
DIMENSIONS								
Length	mm	2 180	2 180	2 180	2 180	2 180	2 180	
Width	mm	1 160	1 160	1 160	1 160	1 160	1 160	
Height	STD	mm	1 986	1 986	1 986	2 286	2 286	2 286
	HPF	mm	2 025	2 026	2 026	2 379	2 379	2 379
WEIGHT								
Operating weight	kg	515	585	585	765	875	895	
ACOUSTICAL DATA								
Sound power level	dB(A)	80	80	80	83	83	83	
Sound pressure level (*)	dB(A)	47.8	47.8	47.8	50.8	50.8	50.8	

(*) Sound pressure levels calculated at 10 meters. Sound pressure levels refer to ISO standard 3744 with parallelepiped shape.

(1) According to EN14511-2013 (2) According to Eurovent

Physical Data - SYSAQUA.H STD

SYSAQUA - Heat pump version		20	25	30	35	40	45	
Cooling capacity	kW	19.4	25.3	26.9	35.8	37.4	46.8	
Power input	kW	6.1	8.6	9.3	13.5	13.6	16.9	
Total EER 100% (1)		3.18	2.94	2.88	2.65	2.74	2.77	
Energy class EER (2)		A	B	C	D	C	C	
SEER (2)		3.91	3.87	3.88	3.68	3.91	3.70	
η _{sc} (2)		153	152	152	144	153	145	
Energy class SEER		B	B	B	B	B	B	
Heating capacity	kW	19.5	26.9	29.7	37.3	41.6	48.5	
Power input	kW	6.1	9.3	9.9	13.2	13.5	17.3	
Total COP 100% (1)		3.19	2.90	2.99	2.82	3.08	2.80	
Energy class COP (2)		B	C	C	C	B	C	
SCOP (2)		3.37	3.27	3.27	3.36	3.40	3.23	
η _{sh} (2)		132	128	128	132	133	126	
Energy class SCOP (2)		A+	A+	A+	A+	A+	A+	
Power supply		400V/3ph+N/50Hz						
Startup type		Direct						
Maximum operating current	A	17.7	22.2	24.3	31.8	33.8	40.2	
Startup current (without Soft Starter)	A	52.7	63.7	77.3	118.3	119.3	133.2	
Startup current (with Soft Starter)	A	28.1	35.2	48.8	53.0	54.0	65.8	
REFRIGERANT								
Type		R410A						
Number of refrigerant circuit		1						
Charge	kg	8.4	8.4	8.4	9.1	9.2	14.5	
COMPRESSORSS								
Number		2	2	2	2	2	2	
Type		Scroll						
Part load steps	%	0/50/100	0/50/100	0/50/100	0/50/100	0/50/100	0/50/100	
Crankcase heater	W	2x40	2 X 40	2 X 70	2 X 70	2 X 70	2 x 90	
EVAPORATOR								
Number		1	1	1	1	1	1	
Type		Plate						
Cooling mode	Water flow	m ³ /h	3.35	4.36	4.64	6.16	6.44	8.06
	Water pressure drop	kPa	23	37	22	37	40	27
Heating mode	Water flow	m ³ /h	3.35	4.64	5.11	6.41	7.16	8.35
	Water pressure drop	kPa	23	44	26	39	48	29
Water volume	l	1.78	1.78	2.55	2.55	2.55	4.1	
Antifreeze heater	W	30	30	30	30	30	30	
COIL								
Number		1	1	1	1	1	1	
Frontal surface	m ²	2.4	2.40	2.4	2.8	2.8	4.2	
Number of rows		2	2	2	2	2	2	
FAN								
Number		1	1	1	1	1	1	
STD	Air flow	m ³ /h	9 000	13 000	13 000	16 000	16 000	22 500
	Rotational speed	tr/mn	900	900	900	650	650	790
	Power input each fan	W	620	940	940	930	930	1 650
HPF	Air flow	m ³ /h	/	14 000	14 000	14 000	14 000	21 000
	Rotational speed	tr/mn	/	870	870	870	870	890
	Power input each fan	W	/	1 950	1 950	1 950	1 950	1 950
	Static pressure	Pa	/	140	140	140	140	100
WATER CONNECTIONS								
Type		Male gas threaded						
Inlet diameter	pouces	1"1/2	1"1/2	1"1/2	1"1/2	1"1/2	2"	
Outlet diameter	pouces	1"1/2	1"1/2	1"1/2	1"1/2	1"1/2	2"	
BUFFER TANK (OPTION)								
Volume	L	100	100	100	100	100	300	
DIMENSIONS								
Length	mm	1 000	1 000	1 000	1 000	1 000	2 180	
Width	mm	1 000	1 000	1 000	1 000	1 000	1 160	
Height	STD	mm	1 983	1 983	1 983	1 983	1 986	
	HPF	mm	2 025	2 025	2 025	2 025	2 025	
WEIGHT								
Operating weight	kg	265	275	305	315	315	515	
ACOUSTICAL DATA								
Sound power level	dB(A)	75	75	75	76	76	80	
Sound pressure level (*)	dB(A)	42.8	42.8	42.8	43.8	43.8	47.8	

(*) Sound pressure levels calculated at 10 meters. Sound pressure levels refer to ISO standard 3744 with parallelepiped shape.

(1) According to EN14511-2013 (2) According to Eurovent

Physical Data - SYSAQUA.H STD

SYSAQUA - Heat pump version		55	65	75	90	105	125	
Cooling capacity	kW	53.3	65.8	71.6	91.4	106.2	121.9	
Power input	kW	19.7	22.1	24.3	34.4	38.1	46.4	
Total EER 100% (1)		2.71	2.98	2.95	2.66	2.79	2.63	
Energy class EER (2)		C	B	B	D	C	D	
SEER (2)		3.86	4.04	3.99	3.89	3.88	3.89	
η_{sc} (2)		151	159	157	153	152	153	
Energy class SEER		B	A	B	B	B	B	
Heating capacity	kW	58.2	67.2	75.9	88.1	101.0	119.1	
Power input	kW	20.3	22.5	24.3	33.8	38.4	45.5	
Total COP 100% (1)		2.86	2.99	3.12	2.61	2.63	2.62	
Energy class COP (2)		C	C	B	D	D	D	
SCOP (2)		3.27	3.43	3.40	3.26	3.31	3.35	
η_{sh} (2)		128	134	133	128	129	131	
Energy class SCOP (2)		A+	A+	A+	A+	A+	A+	
Power supply		400V/3ph+N/50Hz						
Startup type		Direct						
Maximum operating current	A	44.2	59.4	64.4	77.9	86.0	102.0	
Startup current (without Soft Starter)	A	140.2	201.4	206.4	264.9	312.0	350.0	
Startup current (with Soft Starter)	A	72.8	101.0	106.0	127.3	145.8	182.6	
REFRIGERANT								
Type		R410A						
Number of refrigerant circuit		1						
Charge	kg	14.9	18.9	19.0	22.0	27.0	28.5	
COMPRESSORSS								
Number		2	2	2	2	2	2	
Type		Scroll						
Part load steps	%	0/43/57/100	0/40/60/100	0/45/55/100	0/45/55/100	0/38/62/100	0/33/67/100	
Crankcase heater	W	2 x 66	2 x 66	2 x 66	66/82	66/95	66/95	
EVAPORATOR								
Number		1	1	1	1	1	1	
Type		Plate						
Cooling mode	Water flow	m ³ /h	9.18	11.30	12.31	15.73	18.25	20.95
	Water pressure drop	kPa	35	28	33	26	34	45
Heating mode	Water flow	m ³ /h	10.01	11.56	13.07	15.16	17.39	20.48
	Water pressure drop	kPa	39	29	37	23	30	41
Water volume	l	4.1	6.1	6.1	10.8	10.8	10.8	
Antifreeze heater	W	30	2x30	2x30	2x30	2x30	2x30	
COIL								
Number		1	2	2	2	2	2	
Frontal surface	m ²	4.20	5.55	5.55	6.40	6.40	6.40	
Number of rows		2	2	2	2	3	3	
FAN								
Number		1	2	2	2	2	2	
STD	Air flow	m ³ /h	22 500	30 000	30 000	42 000	42 000	42 000
	Rotational speed	tr/mn	790	650	650	790	790	790
	Power input each fan	W	1 650	930	930	1 650	1 650	1 650
HPF	Air flow	m ³ /h	21 000	2 X 16000	2 X 16000	2 X 20000	2 X 20000	2 X 20000
	Rotational speed	tr/mn	890	870	870	890	890	890
	Power input each fan	W	1 950	1 950	1 950	1 950	1 950	1 950
	Static pressure	Pa	100	130	130	100	90	90
WATER CONNECTIONS								
Type		Male gas threaded						
Inlet diameter	pouces	2"	2"	2"	2"1/2	2"1/2	2"1/2	
Outlet diameter	pouces	2"	2"	2"	2"1/2	2"1/2	2"1/2	
BUFFER TANK (OPTION)								
Volume	L	300	300	300	300	300	300	
DIMENSIONS								
Length	mm	2 180	2 180	2 180	2 180	2 180	2 180	
Width	mm	1 160	1 160	1 160	1 160	1 160	1 160	
Height	STD	mm	1 986	1 986	1 986	2 286	2 286	2 286
	HPF	mm	2 025	2 026	2 026	2 379	2 379	2 379
WEIGHT								
Operating weight	kg	515	585	585	765	875	895	
ACOUSTICAL DATA								
Sound power level	dB(A)	80	80	80	83	83	83	
Sound pressure level (*)	dB(A)	47.8	47.8	47.8	50.8	50.8	50.8	

(*) Sound pressure levels calculated at 10 meters. Sound pressure levels refer to ISO standard 3744 with parallelepiped shape.

(1) According to EN14511-2013 (2) According to Eurovent

Weight

Sizes		20	25	30	35	40	45	55	65	75	90	105	125
without pump	kg	260	270	300	310	310	510	510	580	580	760	870	890
Simple pump	kg	+20	+20	+20	+20	+20	+30	+30	+30	+30	+30	+30	+30
Double pump	kg	/	/	/	/	/	+60	+60	+60	+60	+60	+60	+60
S	kg	/	/	/	/	/	+40	+40	+40	+40	+40	+40	+40
buffer tank (dry weight)	without heating	Kg	+65	+65	+65	+65	+65	+160	+160	+160	+160	+160	+160
	with heating	Kg	/	/	/	/	/	+165	+165	+165	+165	+165	+165

Electrical Data

Unit without pump with condenser fans standard

Sizes		20	25	30	35	40	45	55	65	75	90	105	125
Power supply		400V / 3~N / 50Hz											
Maximum current	A	17.7	22.2	24.3	31.8	33.8	40.2	44.2	59.4	64.4	77.9	86.0	102.0
Fuse rating aM	A	20	25	25	32	40	50	50	63	80	80	100	125
Total startup current (without Soft Starter)	A	52.7	63.7	77.3	118.3	119.3	133.2	140.2	201.4	206.4	264.9	312.0	350.0
Total startup current (with Soft Starter)	A	28.1	35.2	48.8	53.0	54.0	65.8	72.8	101.0	106.0	127.3	145.8	182.6

Unit without pump with condenser fans HPF

Sizes		20	25	30	35	40	45	55	65	75	90	105	125
Power supply		400V / 3~N / 50Hz											
Maximum current	A	/	24.5	26.5	33.5	35.5	40.9	44.9	62.8	67.8	79.3	87.4	103.4
Fuse rating aM	A	/	25	32	40	40	50	50	63	80	80	100	125
Total startup current (without Soft Starter)	A	/	66.0	79.5	120.0	121.0	133.9	140.9	204.8	209.8	266.3	313.4	351.4
Total startup current (with Soft Starter)	A	/	37.5	51.0	54.7	55.7	66.5	73.5	104.4	109.4	128.7	147.2	184.0

Electrical Data

Unit with standard pump and condenser fans standard

Sizes		20	25	30	35	40	45	55	65	75	90	105	125
Power supply		400V / 3~N / 50Hz											
Maximum current	A	19.5	24.0	26.1	34.4	36.4	42.8	49.1	64.3	69.3	82.8	90.9	106.9
Fuse rating aM	A	20	25	32	40	40	50	50	80	80	100	100	125
Total startup current (without Soft Starter)	A	54.5	65.5	79.1	120.9	121.9	135.8	145.1	206.3	211.3	269.8	316.9	354.9
Total startup current (with Soft Starter)	A	29.9	37.0	50.6	55.6	56.6	68.4	77.7	105.9	110.9	132.2	150.7	187.5

Unit with standard pump and condenser fans HPF

Sizes		20	25	30	35	40	45	55	65	75	90	105	125
Power supply		400V / 3~N / 50Hz											
Maximum current	A	/	26.3	28.4	36.1	38.1	43.5	49.8	67.7	72.7	84.2	92.3	108.3
Fuse rating aM	A	/	32	32	40	40	50	50	80	80	100	100	125
Total startup current (without Soft Starter)	A	/	67.8	81.4	122.6	123.6	136.5	145.8	209.7	214.7	271.2	318.3	356.3
Total startup current (with Soft Starter)	A	/	39.3	52.9	57.3	58.3	69.1	78.4	109.3	114.3	133.6	152.1	188.9

Simple pump 1P (400V/3/50Hz)

Sizes	Nominal power (kW)	Max. current (A)
20	0.75	1.82
25	0.75	1.82
30	0.75	1.82
35	1.1	2.57
40	1.1	2.57
45	1.1	2.57
55	2.2	4.9
65	2.2	4.9
75	2.2	4.9
90	2.2	4.9
105	2.2	4.9
125	2.2	4.9

Double pump 2P (400V/3/50Hz)

Sizes	Nominal power (kW)	Max. current (A)
20	/	/
25	/	/
30	/	/
35	/	/
40	/	/
45	1.1	2.57
55	2.2	4.9
65	2.2	4.9
75	2.2	4.9
90	2.2	4.9
105	2.2	4.9
125	2.2	4.9

Electric heating coil

			45	55	65	75	90	105	125
Power supply			400V / 3~ N / 50Hz						
Low power heating	Power	kW	12	12	12	12	24	24	24
	Maximum intensity	A	19	19	19	19	38	38	38
High power heating	Power	kW	24	24	24	24	36	36	36
	Maximum intensity	A	38	38	38	38	57	57	57

Acoustical Data

Sound power level Lw-dB - condenser fans standard

SYSAQUA.L/ SYSAQUA.H models	Frequency in octave band (Hz)						Lw global dB (A)	Sound pressure level dB(A) *
	125	250	500	1000	2000	4000		
20	66	68	70	70	69	66	75	42.8
25	66	68	70	70	69	66	75	42.8
30	66	68	70	70	69	66	75	42.8
35	67	69	70	71	70	67	76	43.8
40	67	69	70	71	70	67	76	43.8
45	72	74	77	76	74	69	80	47.8
55	72	74	77	76	74	69	80	47.8
65	72	74	77	76	74	69	80	47.8
75	72	74	77	76	74	69	80	47.8
90	76	77	78	78	78	72	83	50.8
105	76	77	78	78	78	72	83	50.8
125	76	77	78	78	78	72	83	50.8

Sound power level Lw-dB - condenser fans standard - S version

SYSAQUA.L/ SYSAQUA.H models	Frequency in octave band (Hz)						Lw global dB (A)	Sound pressure level dB(A) *
	125	250	500	1000	2000	4000		
45	69	71	74	73	71	66	77	45
55	69	71	74	73	71	66	77	45
65	69	71	74	73	71	66	77	45
75	69	71	74	73	71	66	77	45
90	72	73	74	74	74	68	79	47
105	72	73	74	74	74	68	79	47
125	72	73	74	74	74	68	79	47

Sound power level Lw-dB - condenser fans HPF

SYSAQUA.L/ SYSAQUA.H models	Frequency in octave band (Hz)						Lw global dB (A)	Sound pressure level dB(A) *
	125	250	500	1000	2000	4000		
20	/	/	/	/	/	/	/	/
25	70	72	74	74	73	70	79	47
30	70	72	74	74	73	70	79	47
35	71	73	74	75	74	71	80	48
40	71	73	74	75	74	71	80	48
45	73	75	78	77	75	70	81	49
55	73	75	78	77	75	70	81	49
65	74	76	79	78	76	71	82	50
75	74	76	79	78	76	71	82	50
90	77	78	79	79	79	73	84	52
105	77	78	79	79	79	73	84	52
125	77	78	79	79	79	73	84	52

(*) Sound pressure levels calculated at 10 meters. Sound pressure levels refer to ISO standard 3744 with parallelepiped shape.

Water Pressure Drop of Indoor Heat Exchanger

SYSAQUA 20 - 25 - 30 - 35 - 40 - 45

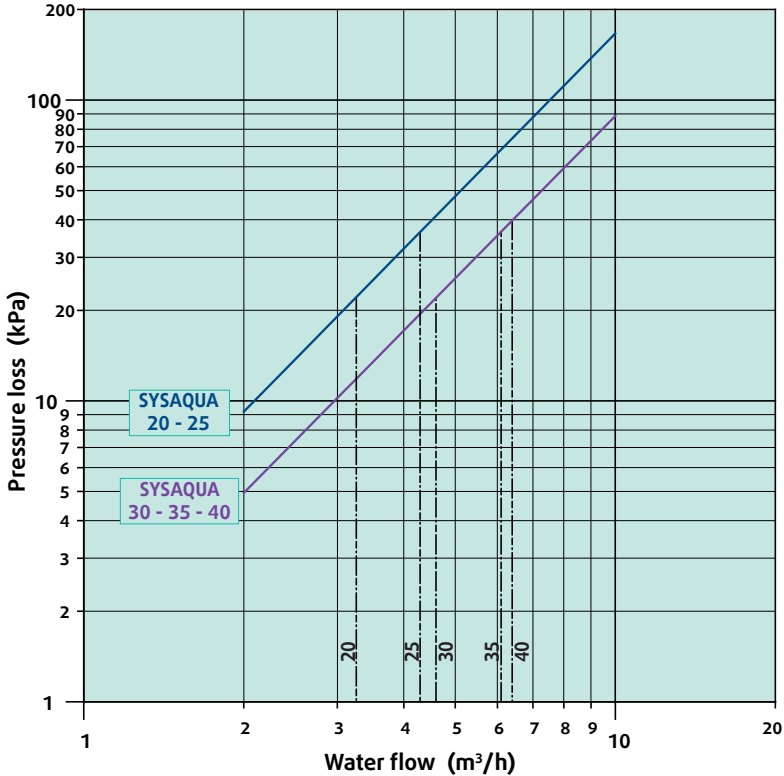

SYSAQUA 45 - 55 - 65 - 75 - 90 - 105 - 125

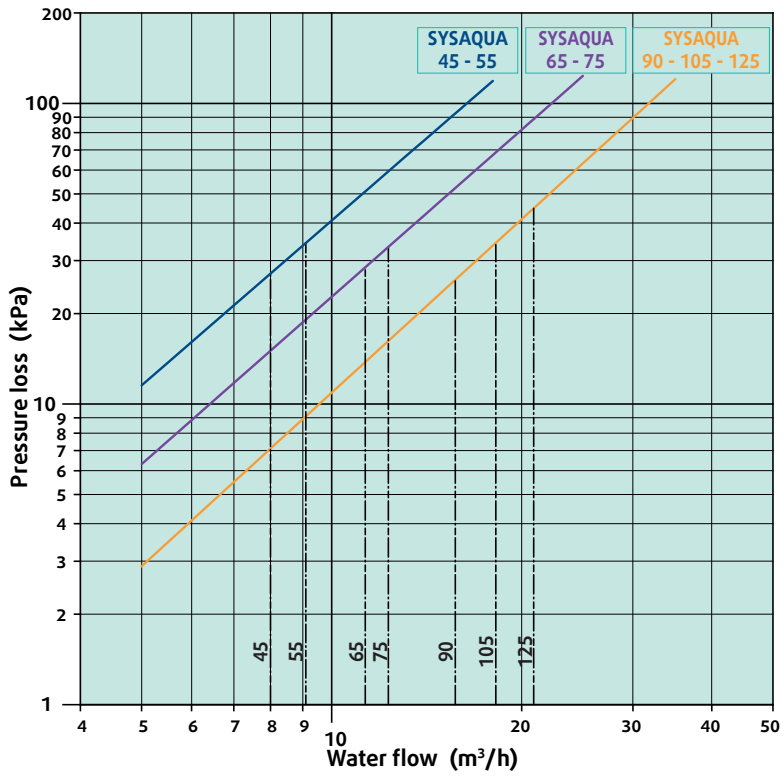

Water Pump Curves

SYSAQUA 20 - 25 - 30

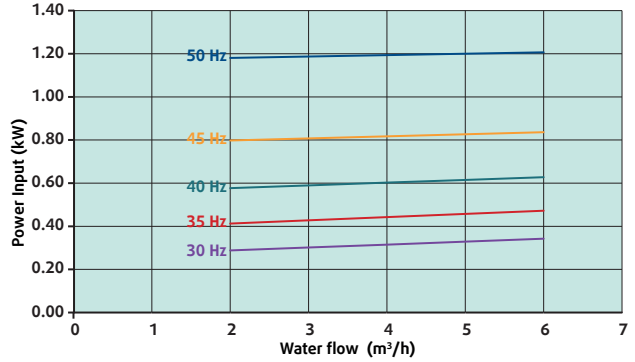
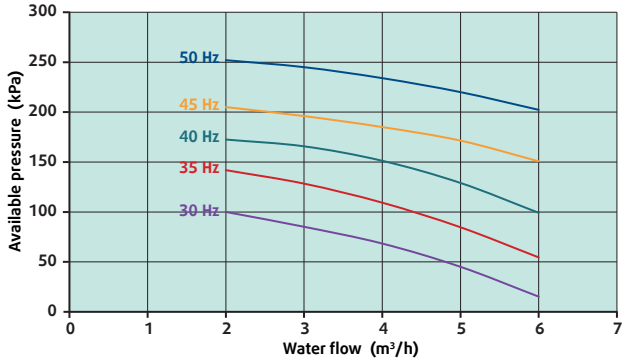

SYSAQUA 35 - 40 - 45

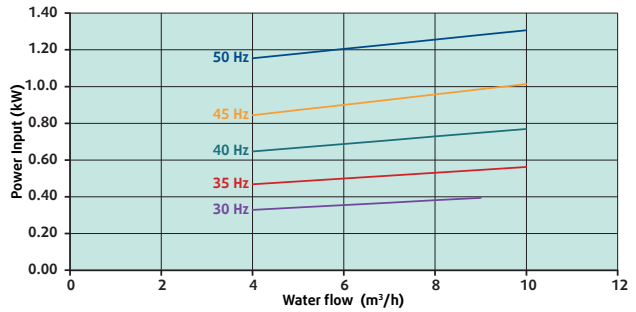
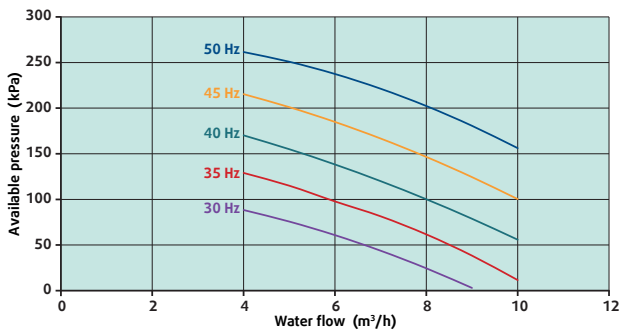

SYSAQUA 55 - 65 - 75 - 90

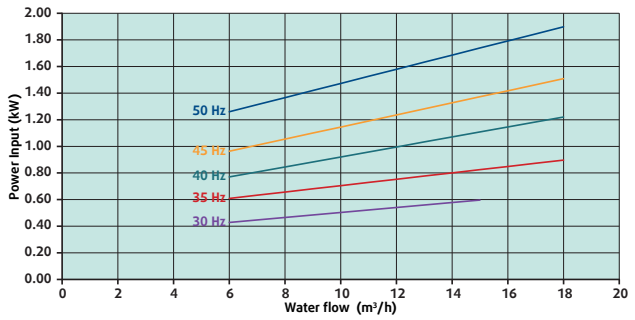
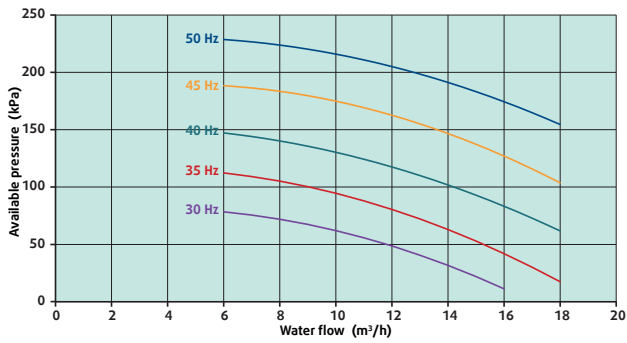

SYSAQUA 105 - 125

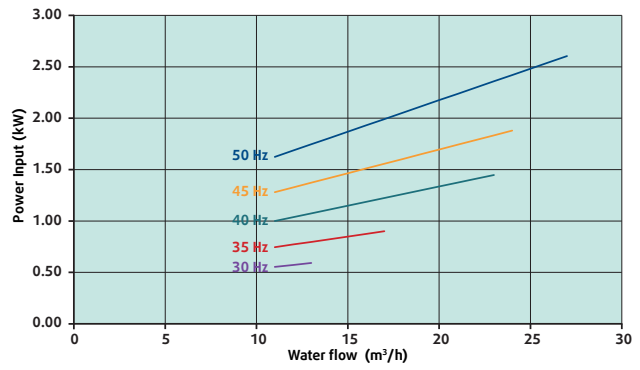
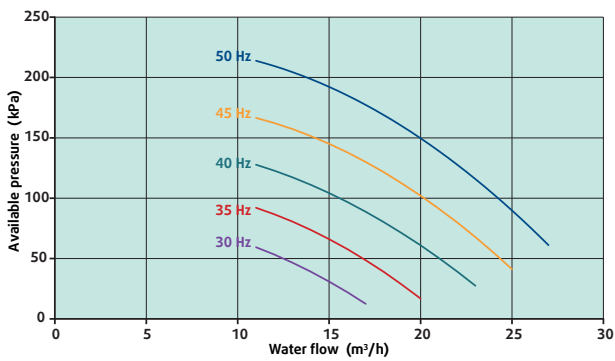

Dimensions (mm)

SYSAQUA.L/SYSAQUA.H 20 to 40 - fan standard

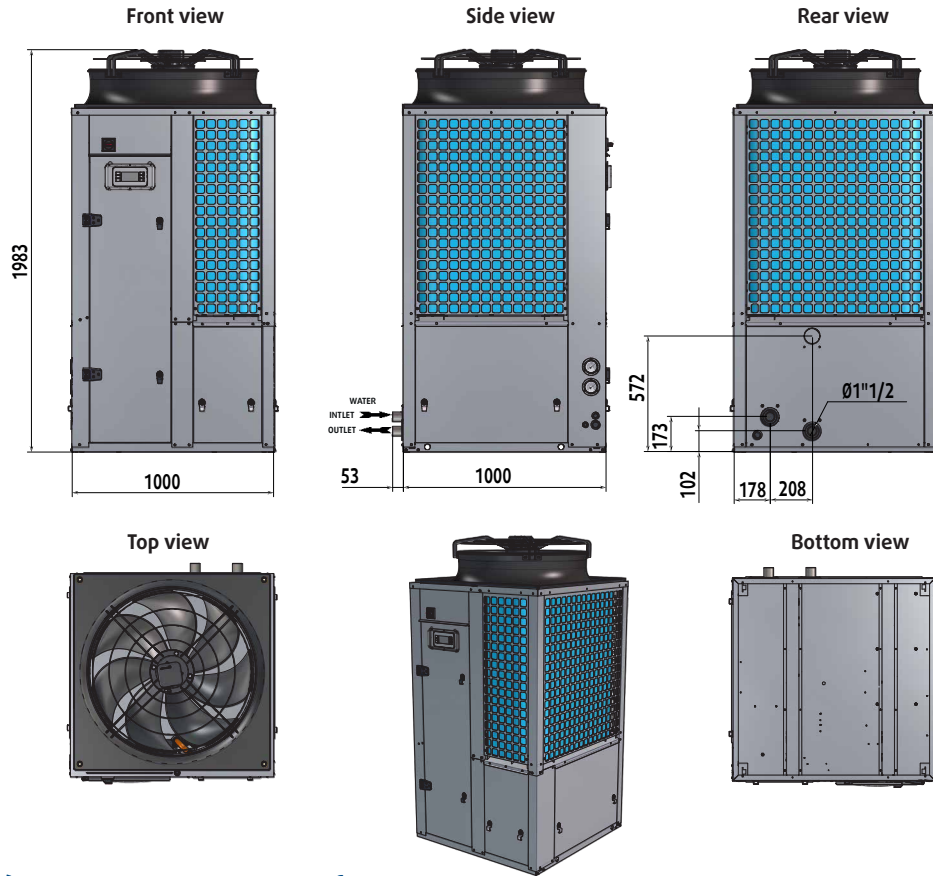

SYSAQUA.L/SYSAQUA.H 25 to 40 - fan HPF

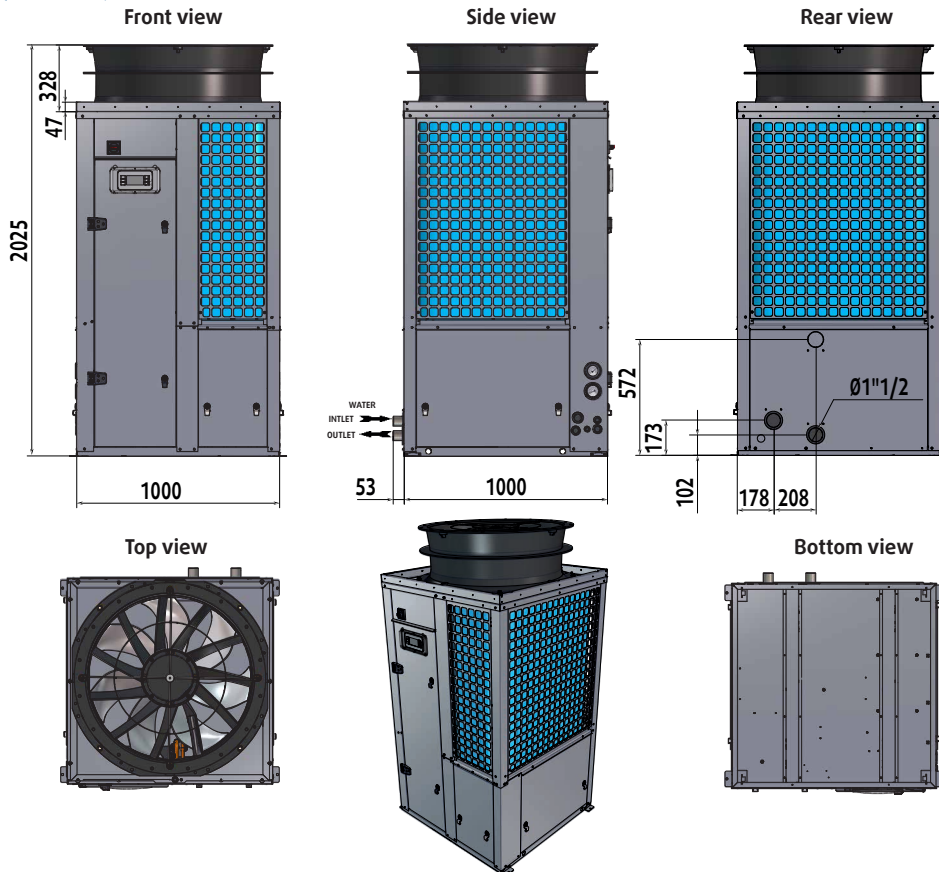

Dimensions (mm)

SYSAQUA.L/SYSAQUA.H 20 to 40 with buffer tank - fan standard

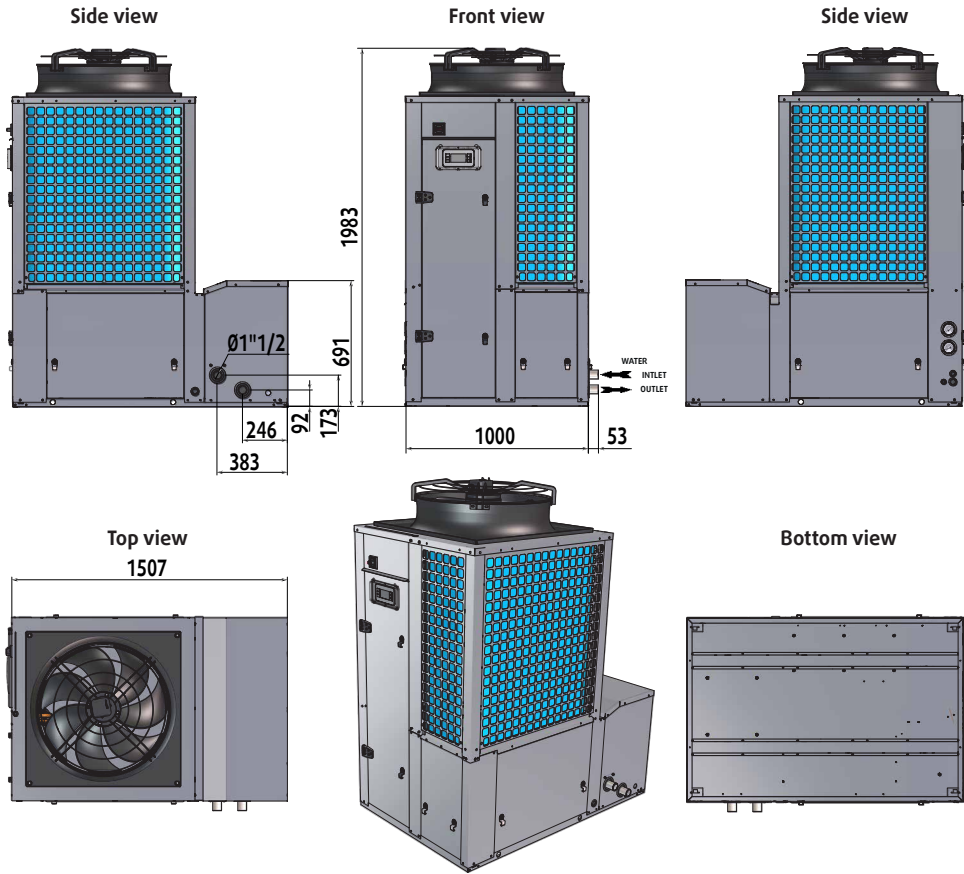

SYSAQUA.L/SYSAQUA.H 25 to 40 with buffer tank - fan HPF

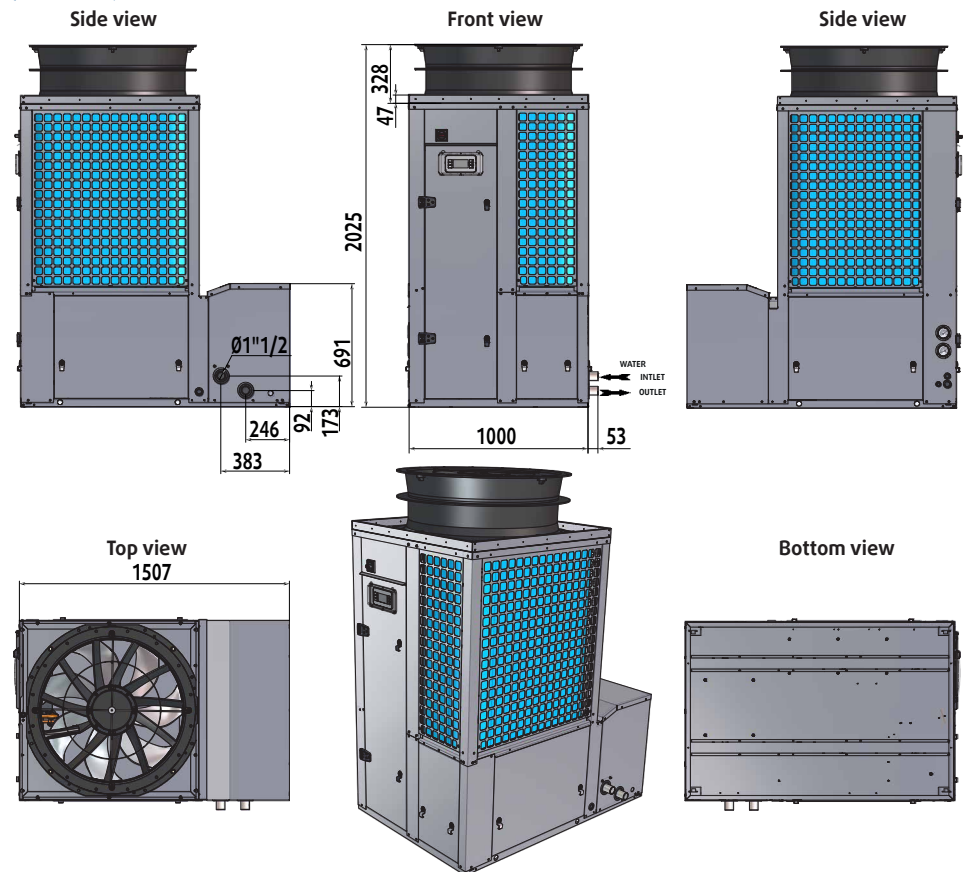

Dimensions (mm)

SYSAQUA.L/SYSAQUA.H 45 to 55 - fan standard

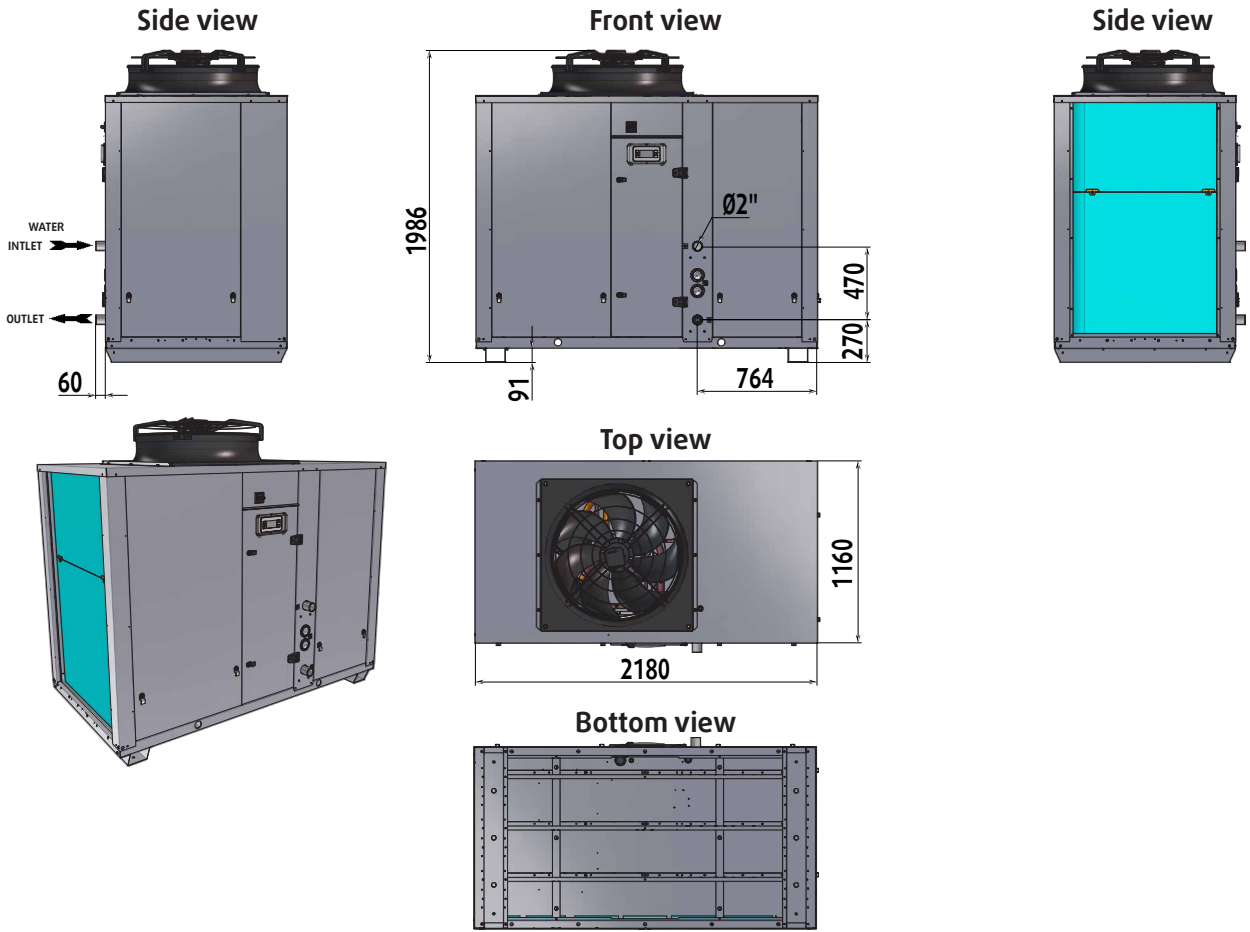

SYSAQUA.L/SYSAQUA.H 45 to 55 - fan HPF

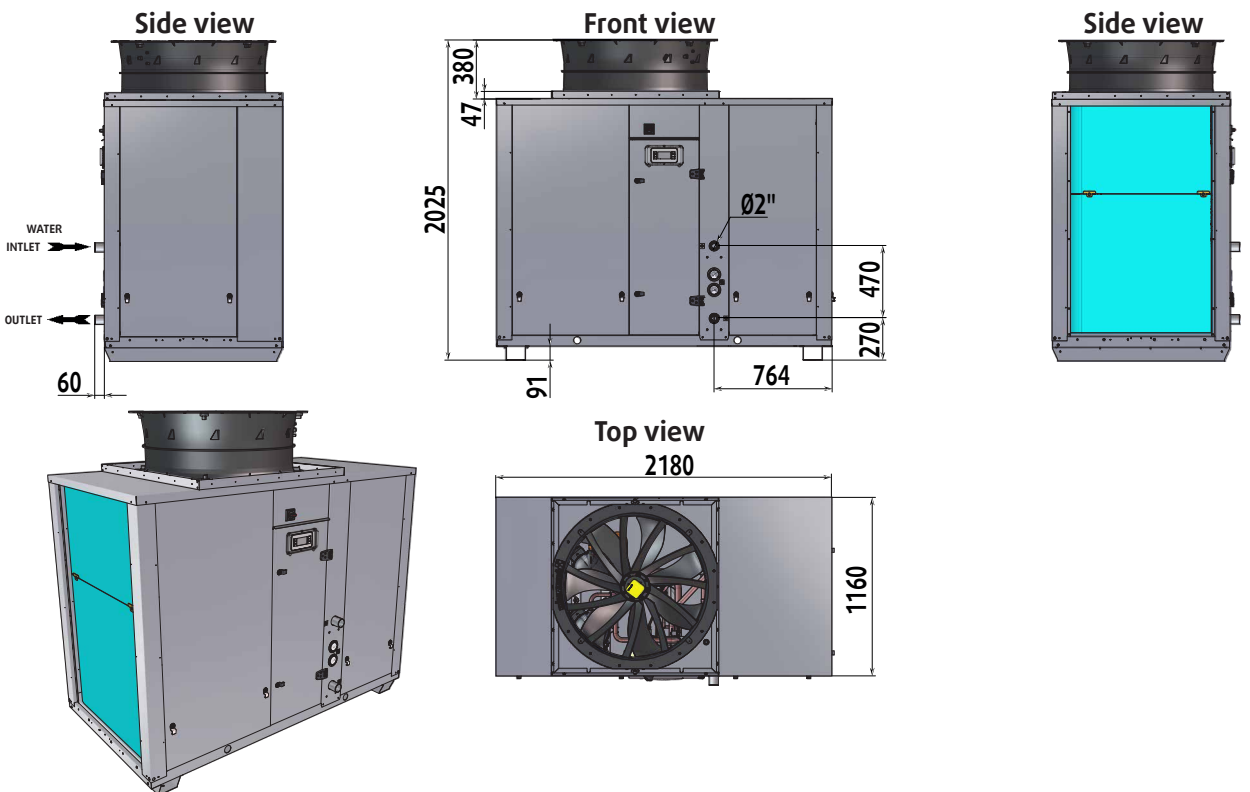

Dimensions (mm)

SYSAQUA.L/SYSAQUA.H 45 to 55 with buffer tank - fan standard

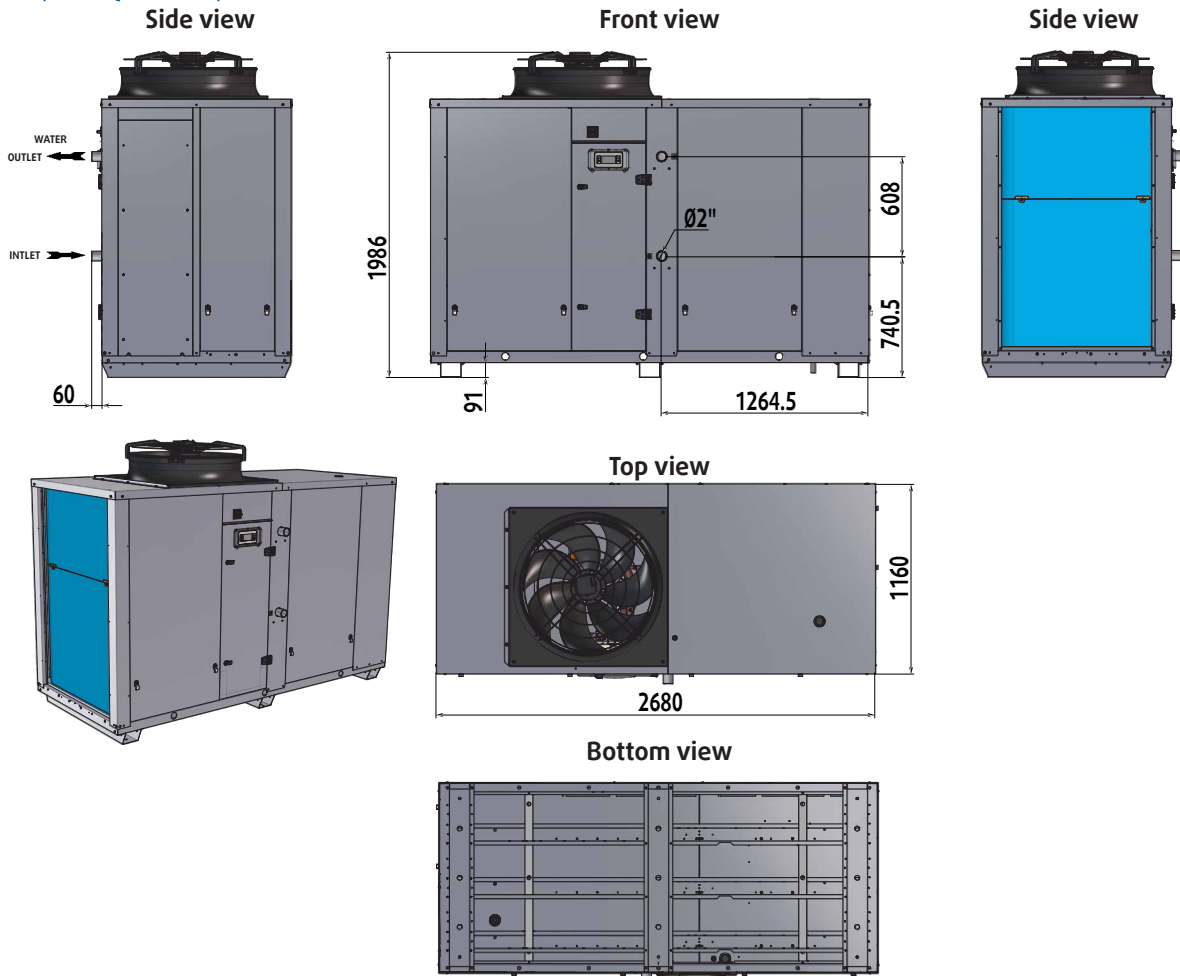

SYSAQUA.L/SYSAQUA.H 45 to 55 with buffer tank - fan HPF

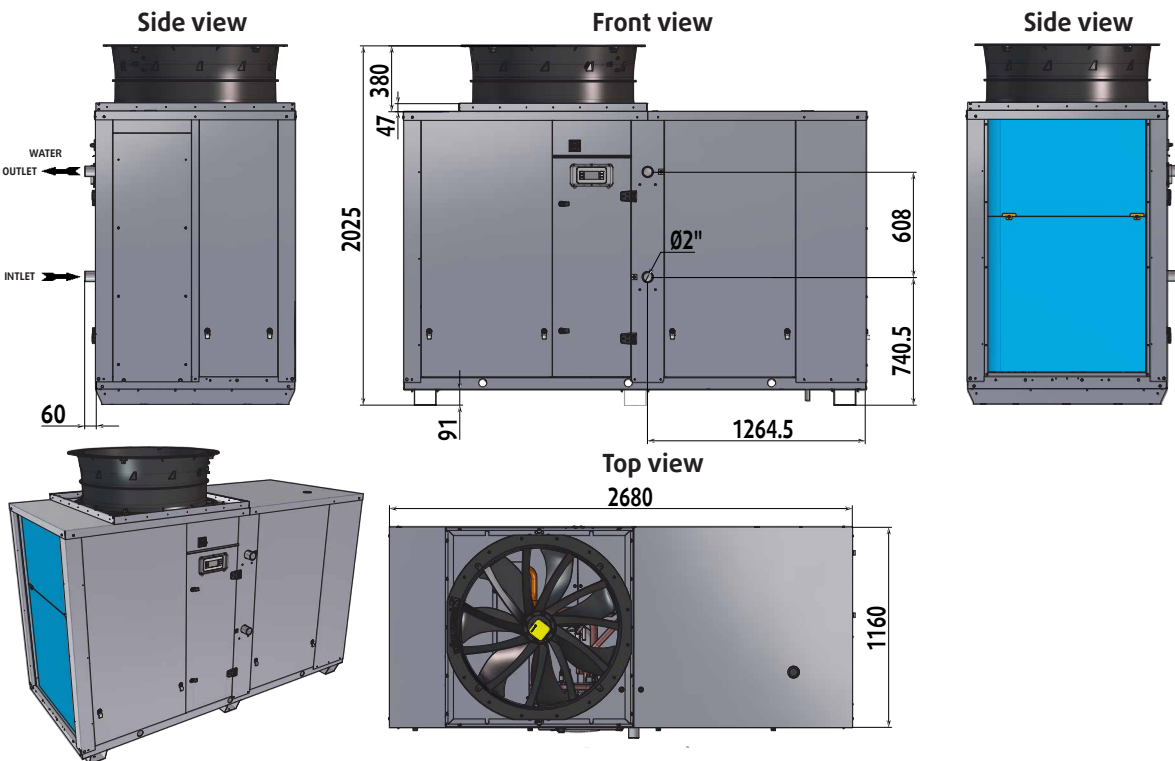

Dimensions (mm)

SYSAQUA.L/SYSAQUA.H 65 to 75 - fan standard

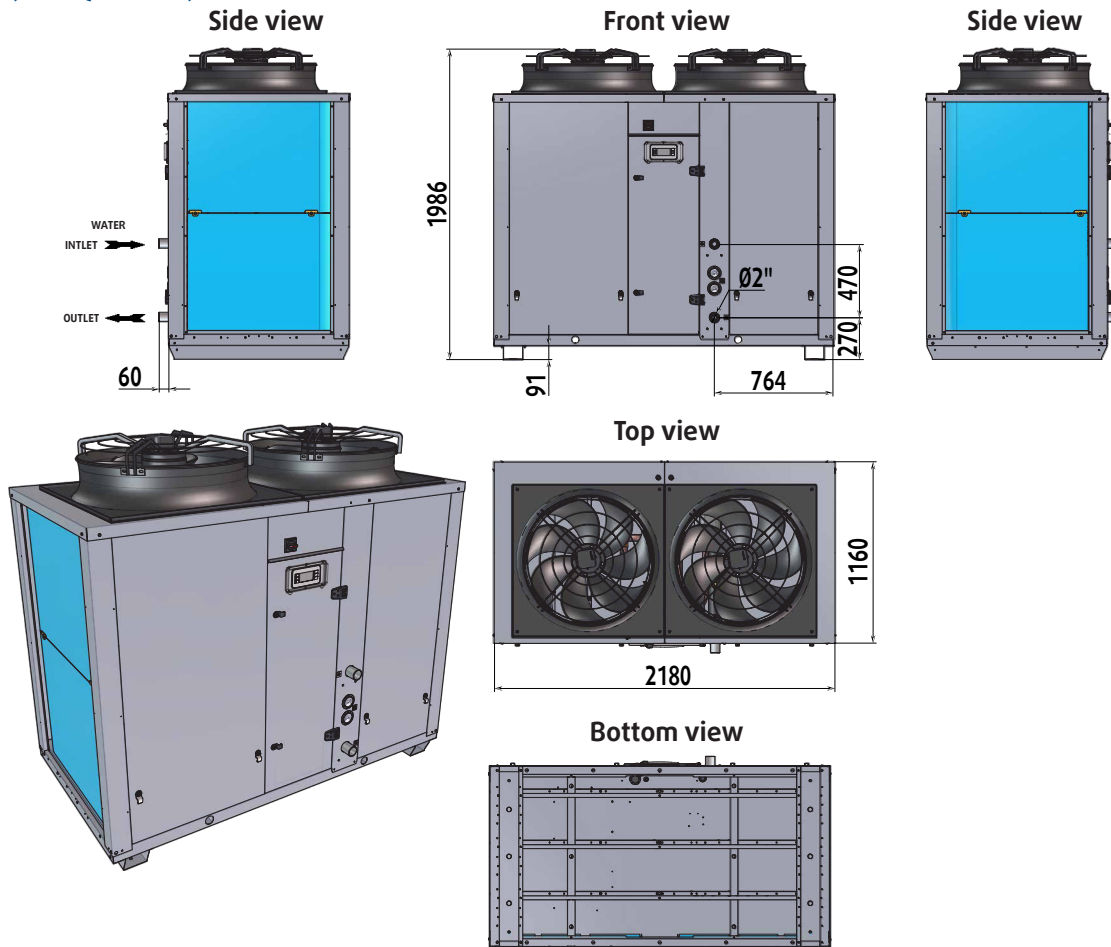

SYSAQUA.L/SYSAQUA.H 65 to 75 - fan HPF

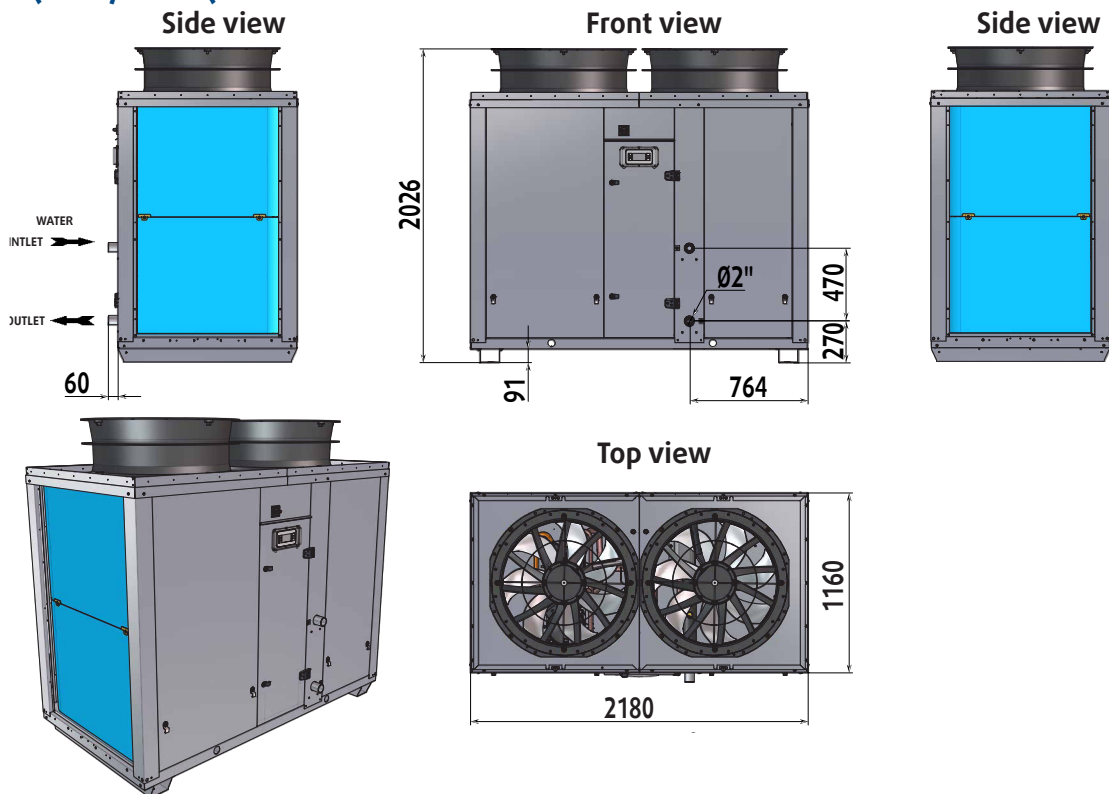

Dimensions (mm)

SYSAQUA.L/SYSAQUA.H 65 to 75 with buffer tank - fan standard

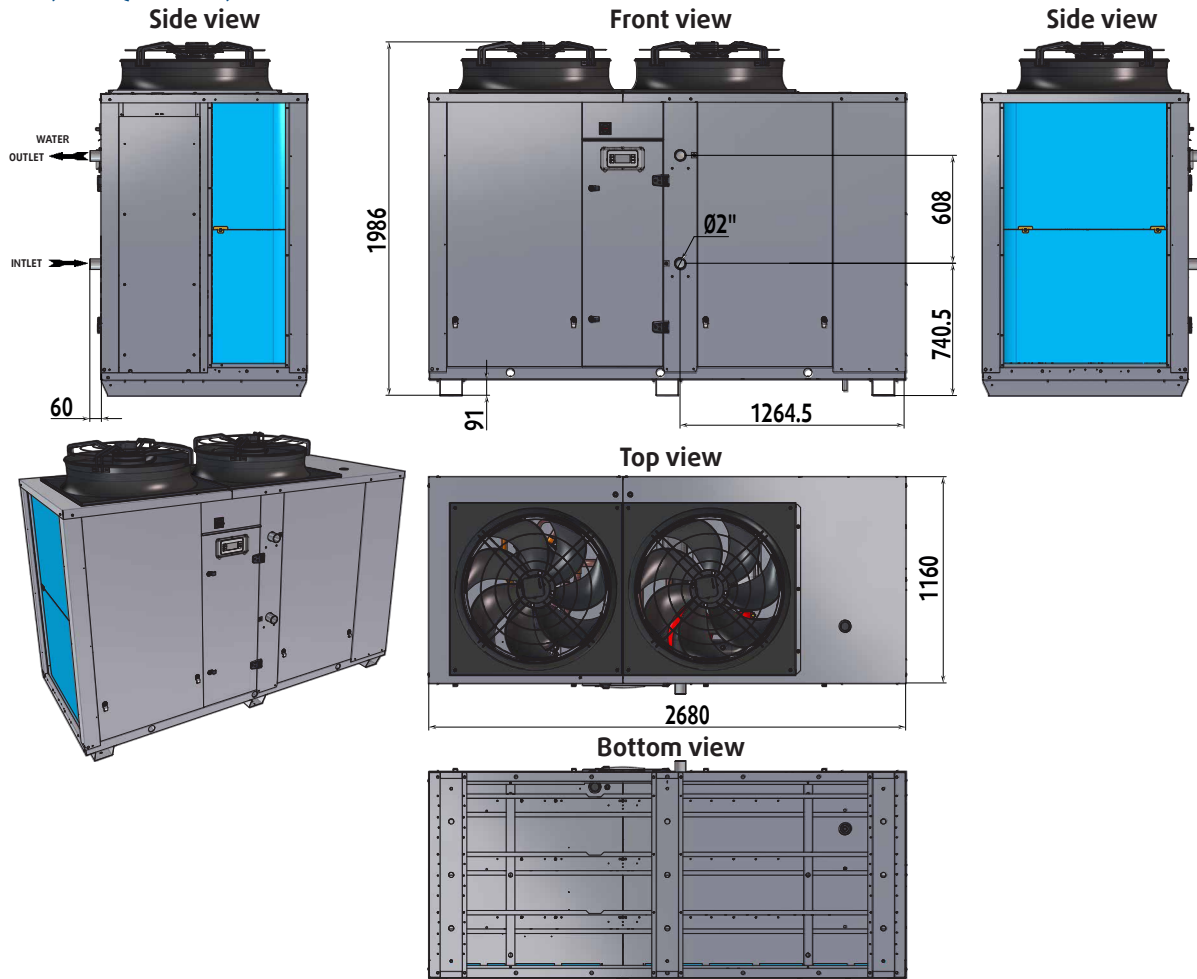

SYSAQUA.L/SYSAQUA.H 65 to 75 with buffer tank - fan HPF

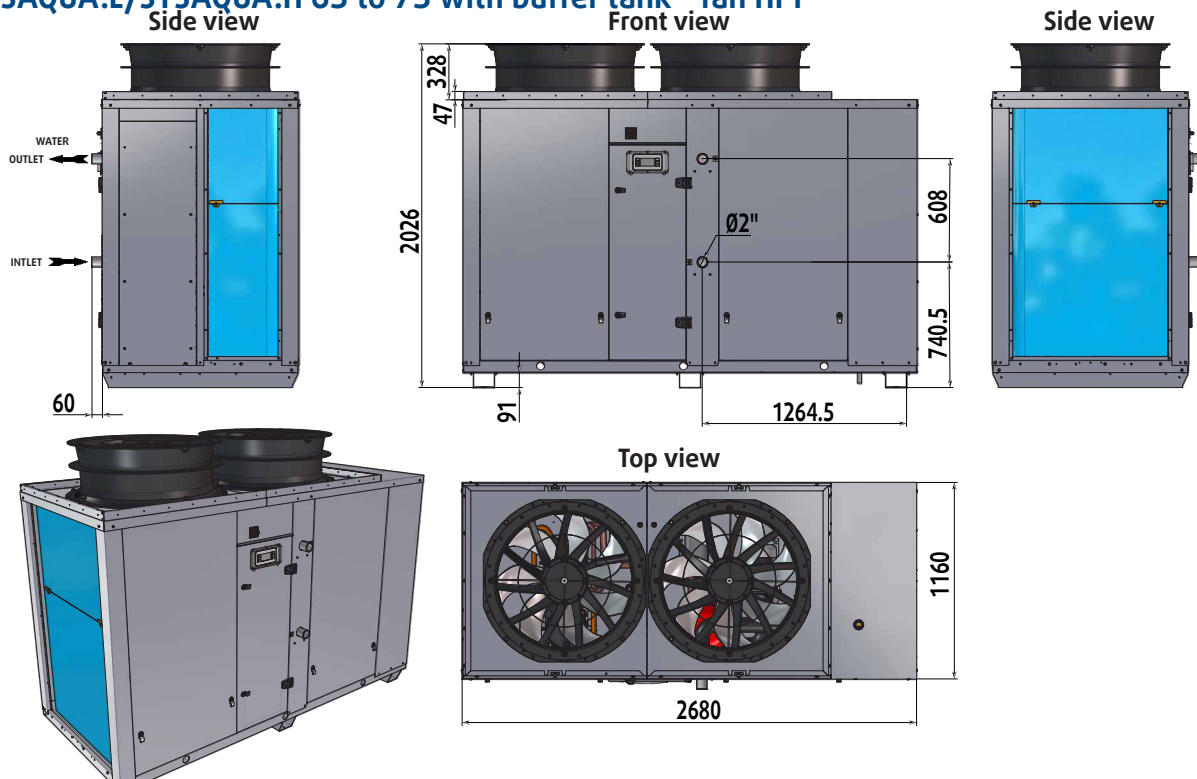

Dimensions (mm)

SYSAQUA.L/SYSAQUA.H 90 to 125 - fan standard

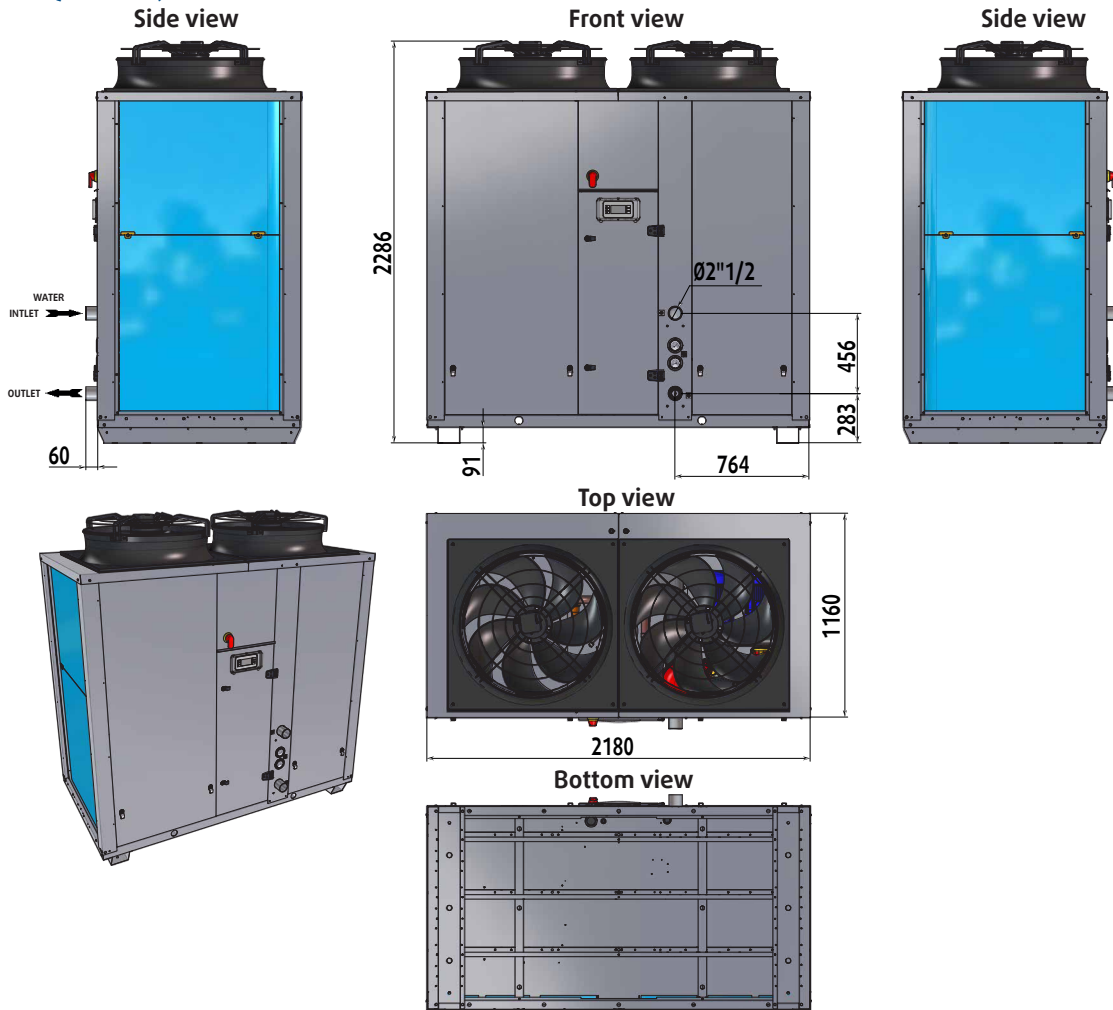

SYSAQUA.L/SYSAQUA.H 90 to 125 - fan HPF

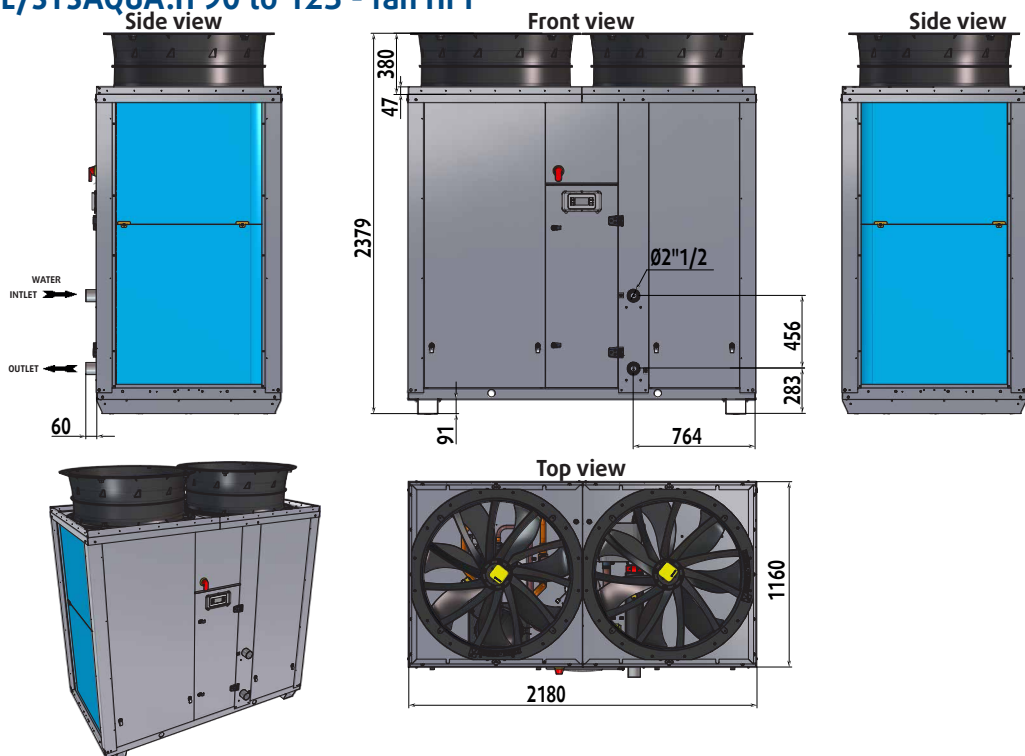

Dimensions (mm)

SYSAQUA.L/SYSAQUA.H 90 to 125 with buffer tank - fan standard

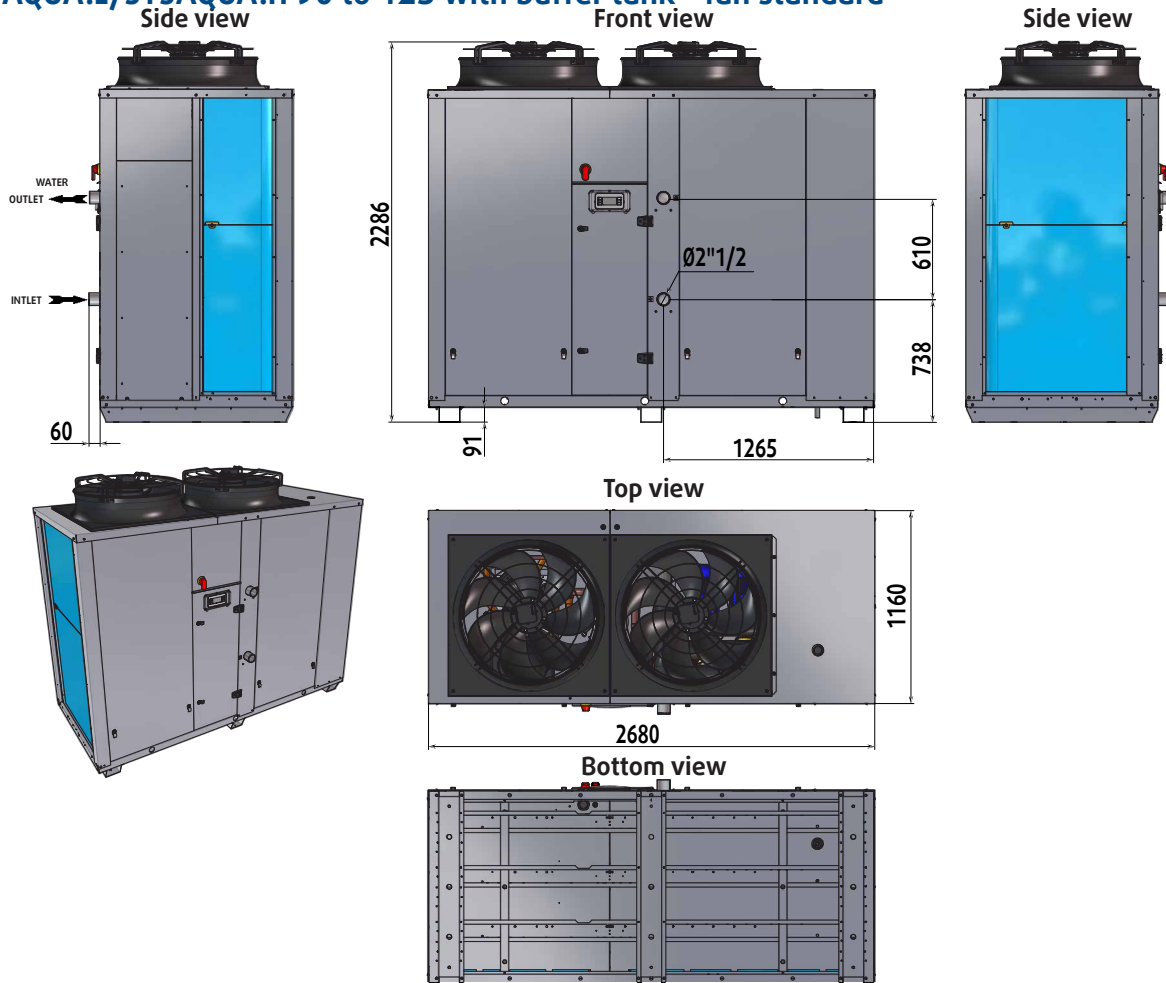

SYSAQUA.L/SYSAQUA.H 90 to 125 with buffer tank - fan HPF

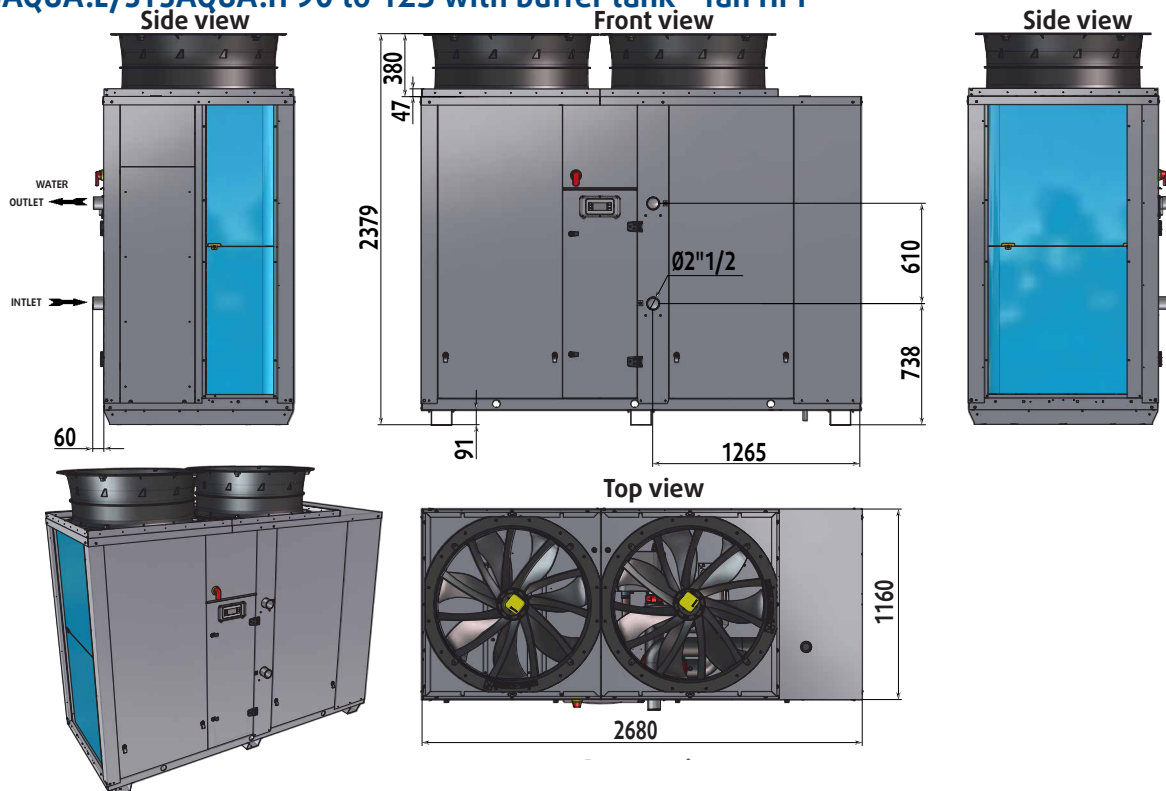

Duct outlet dimensions (mm)

SYSAQUA 25 - 30 - 35 - 40

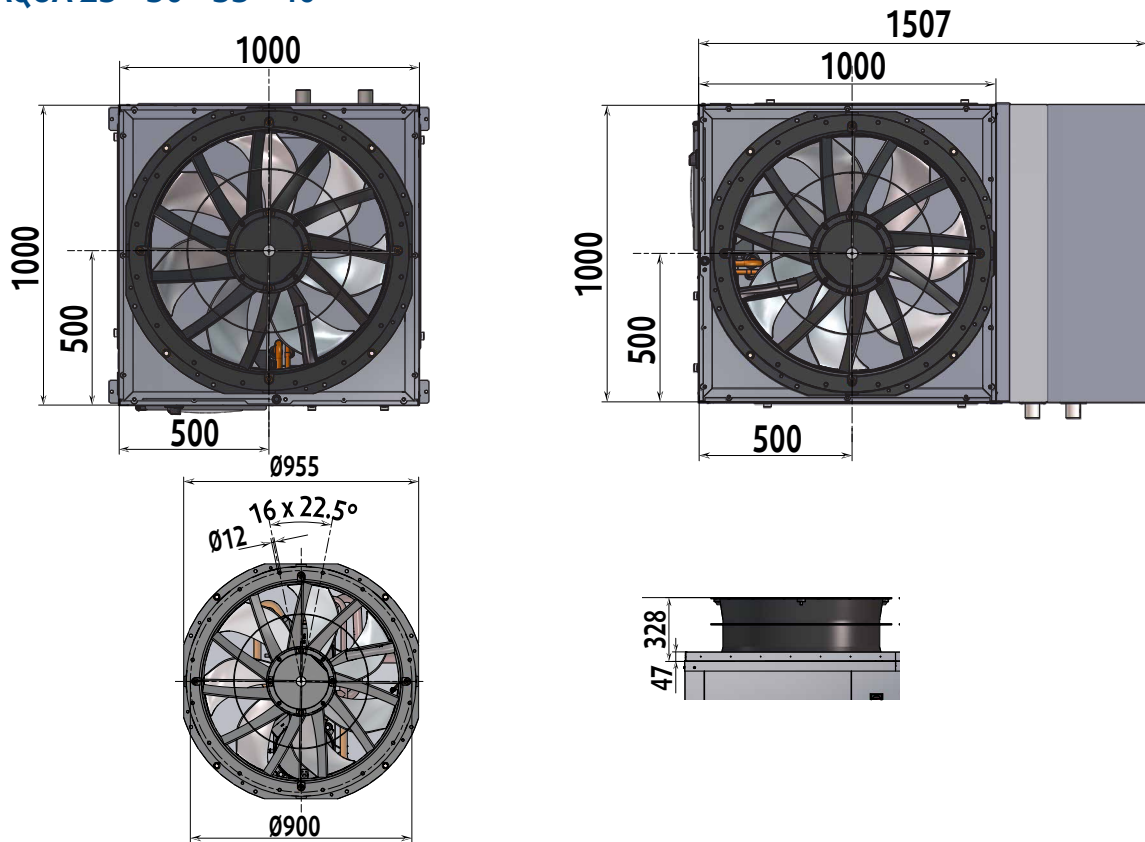

SYSAQUA 45 - 55

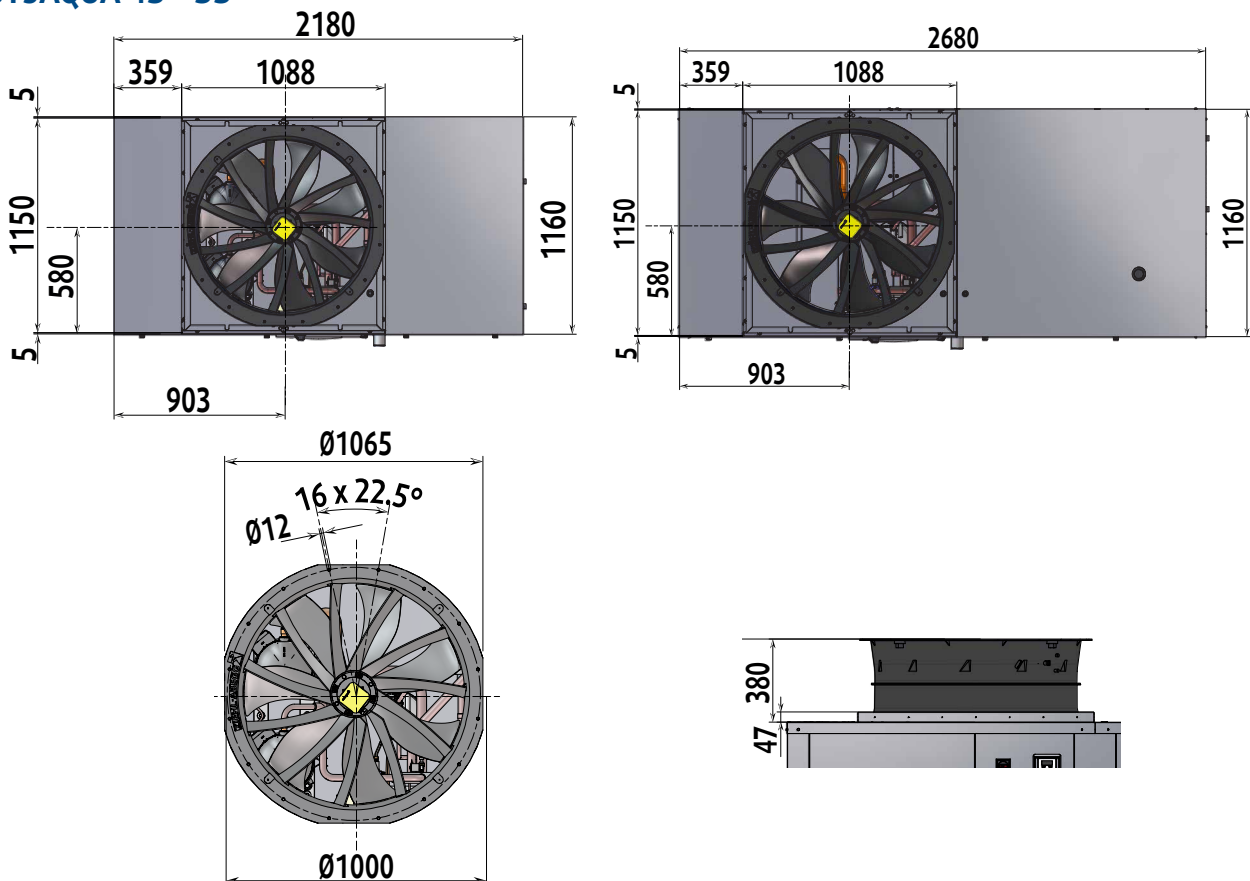

Duct outlet dimensions (mm)

SYSAQUA 65 - 75

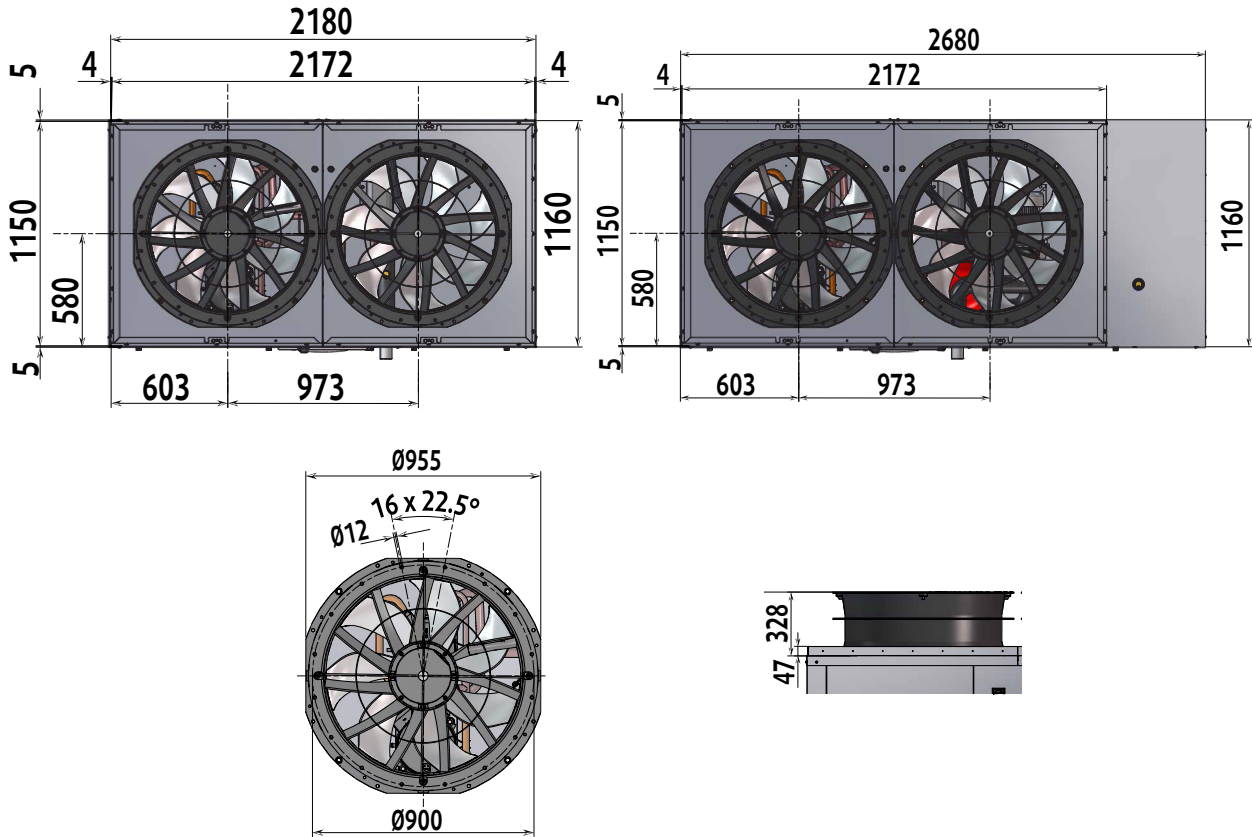

SYSAQUA 90 - 105 - 125

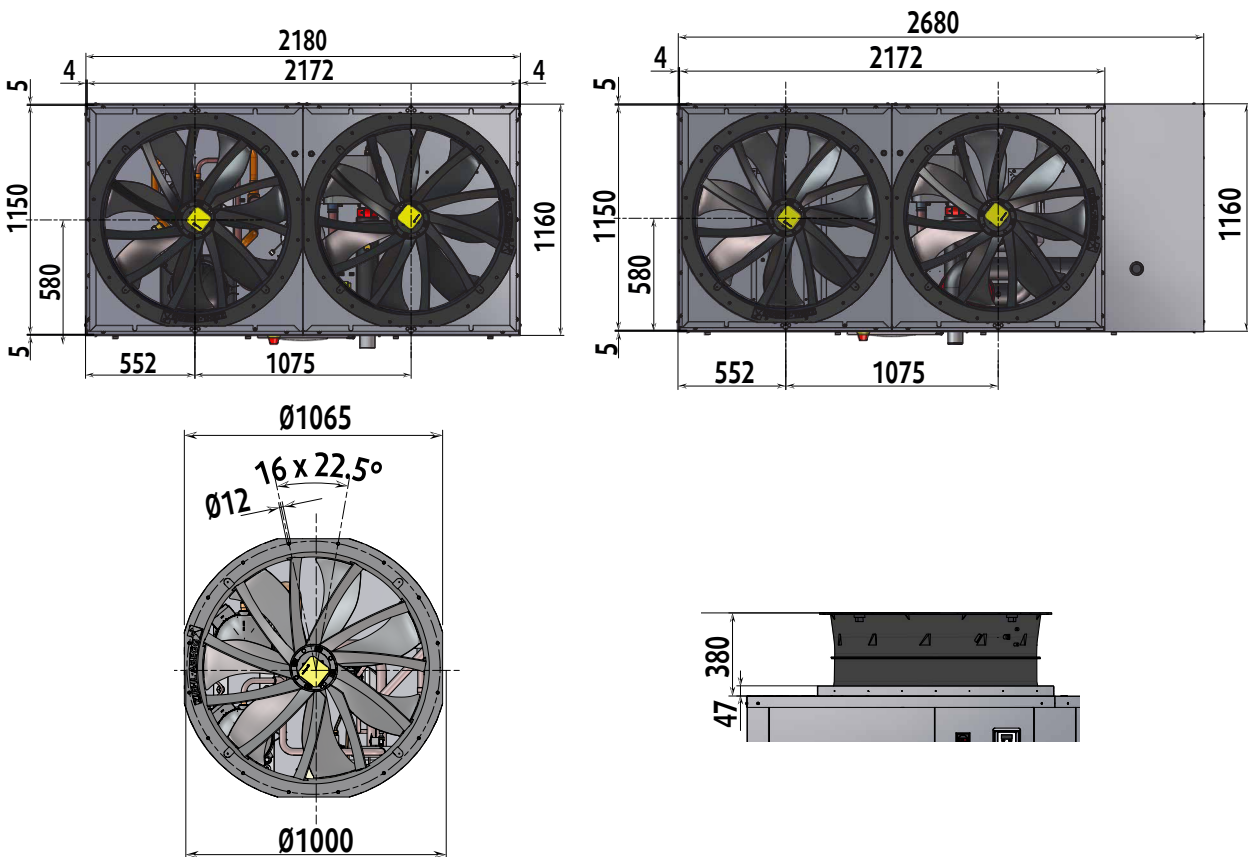

Space Requirements (mm)

SYSAQUA.L/SYSAQUA.H 20 to 40

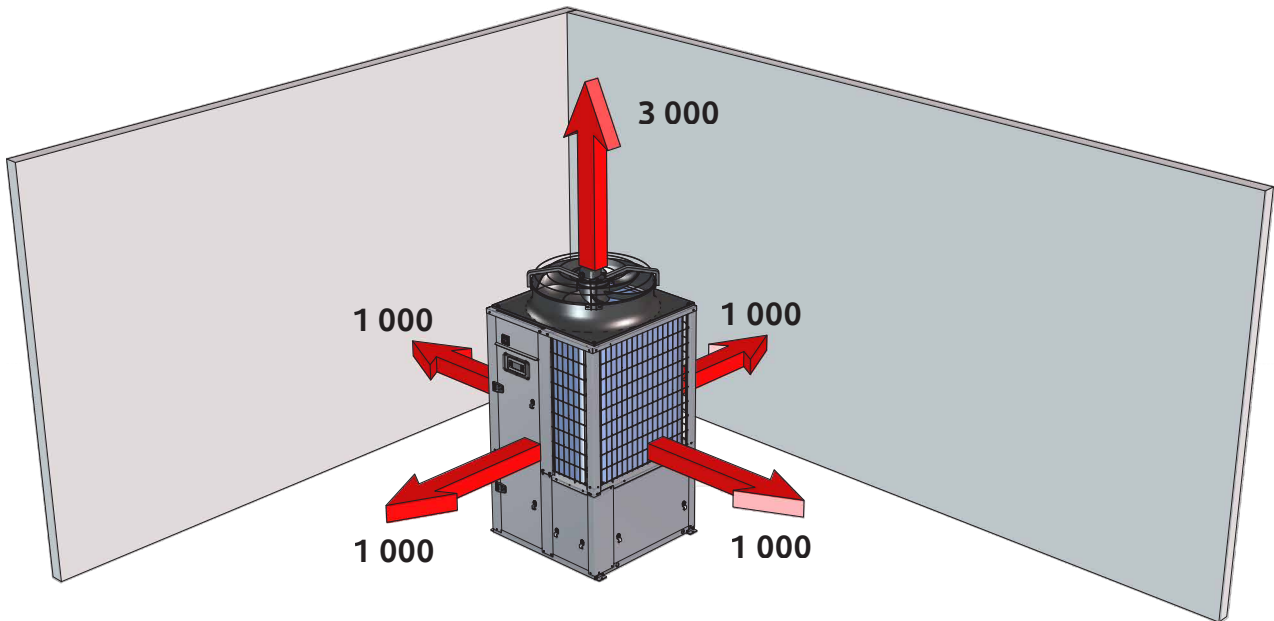

SYSAQUA.L/SYSAQUA.H 45 to 125

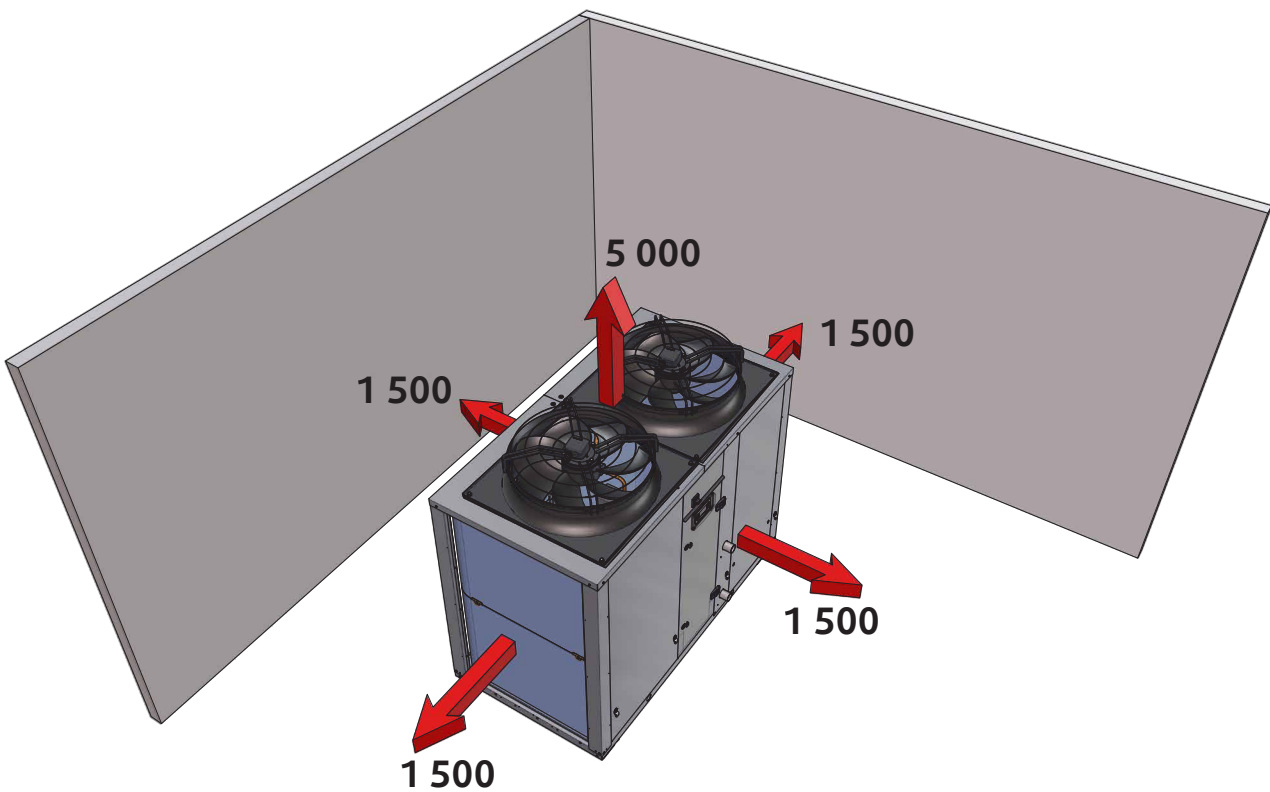

Masses distributions

SYSAQUA.L/SYSAQUA.H 20 to 40

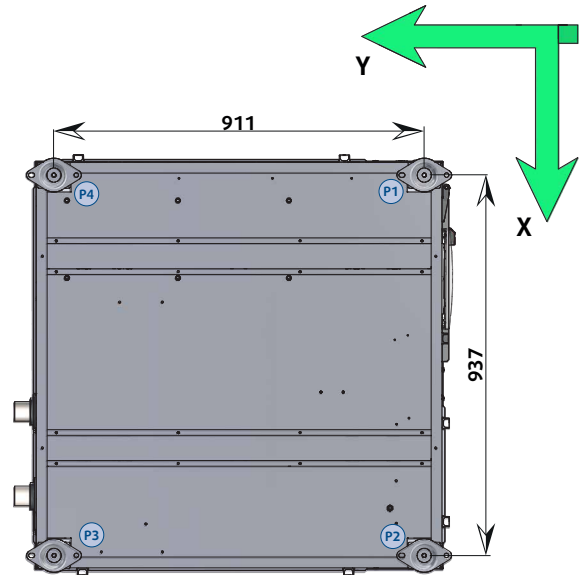

	M*	XG	YG	ZG	P1	P2	P3	P4
	kg	mm	mm	mm	kg	kg	kg	kg
20	280	470	460	850	69	70	71	70
25	290	470	460	850	72	72	73	73
30	320	470	460	850	79	79	81	81
35	330	470	460	850	81	82	84	83
40	330	470	460	850	81	82	84	83

* Operating weight

SYSAQUA.L/SYSAQUA.H 25 to 40 with buffer tank

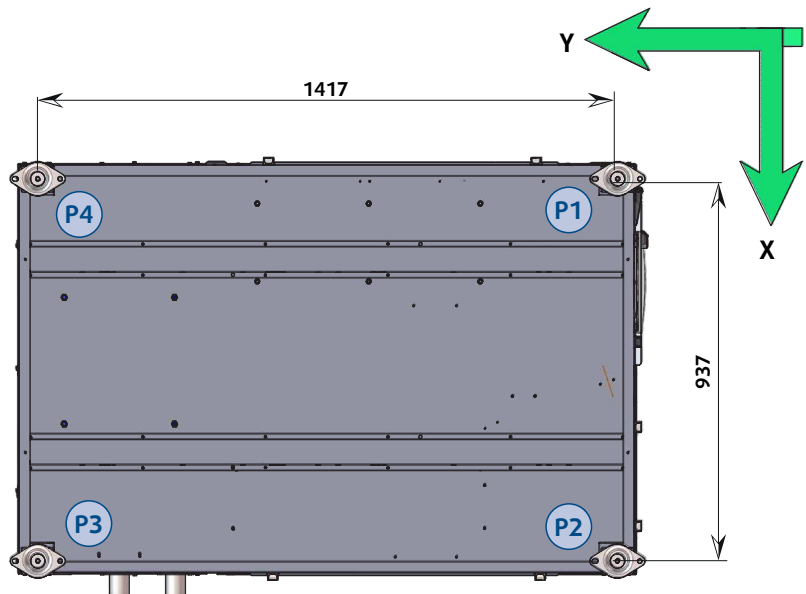
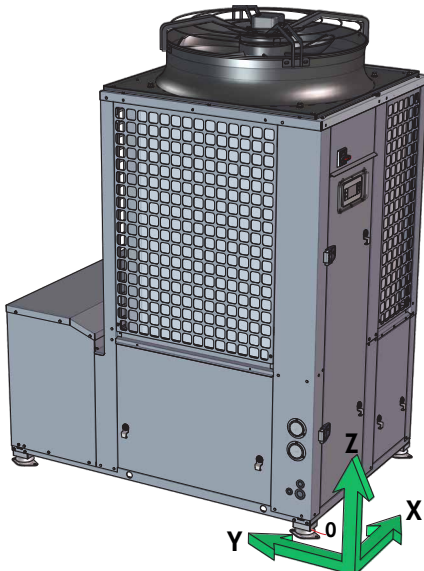

	M*	XG	YG	ZG	P1	P2	P3	P4
	kg	mm	mm	mm	kg	kg	kg	kg
20	460	480	640	800	123	129	107	101
25	465	480	640	800	125	130	108	102
30	495	480	640	800	133	139	115	109
35	505	480	640	800	135	142	117	111
40	505	480	640	800	135	142	117	111

* Operating weight

Masses distributions

SYSAQUA.L/SYSAQUA.H 45 to 125 without buffer tank

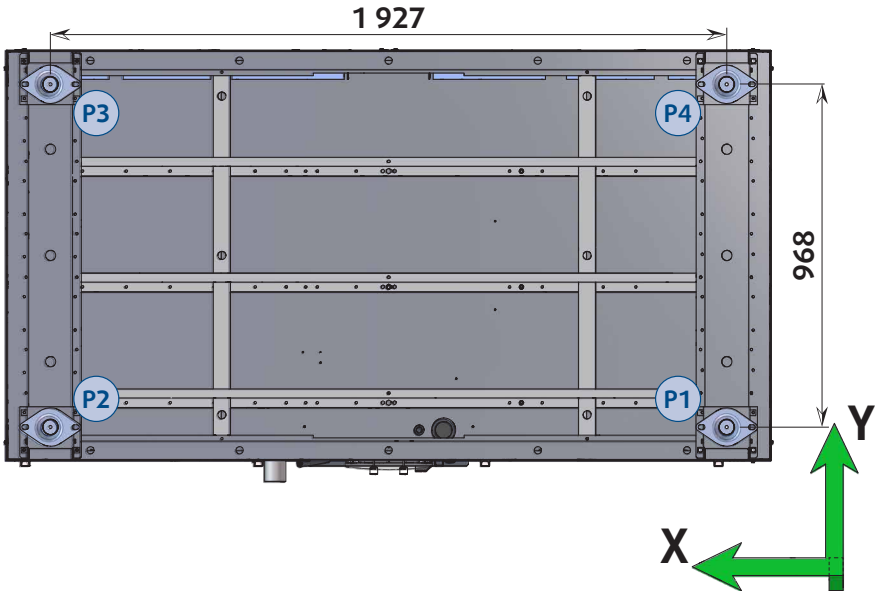
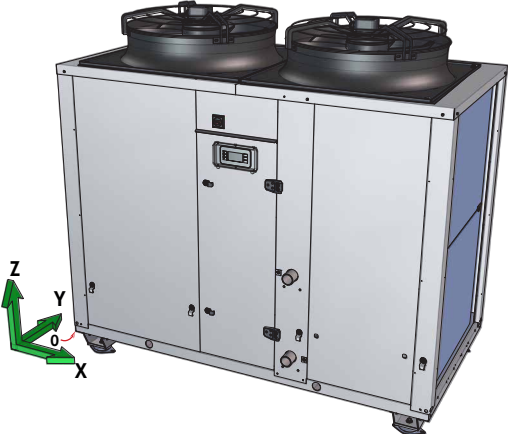

	M*	XG	YG	ZG	P1	P2	P3	P4
	kg	mm	mm	mm	kg	kg	kg	kg
45	540	940	480	700	139	133	131	137
55	540	940	480	700	139	133	131	137
65	610	1 000	540	750	129	141	176	164
75	610	1 000	540	750	129	141	176	164
90	790	1 000	500	850	183	198	212	197
105	900	1 000	500	850	209	226	241	224
125	920	1 000	500	850	214	231	246	229

* Operating weight

Masses distributions

SYSAQUA.L/SYSAQUA.H 45 to 125 with buffer tank

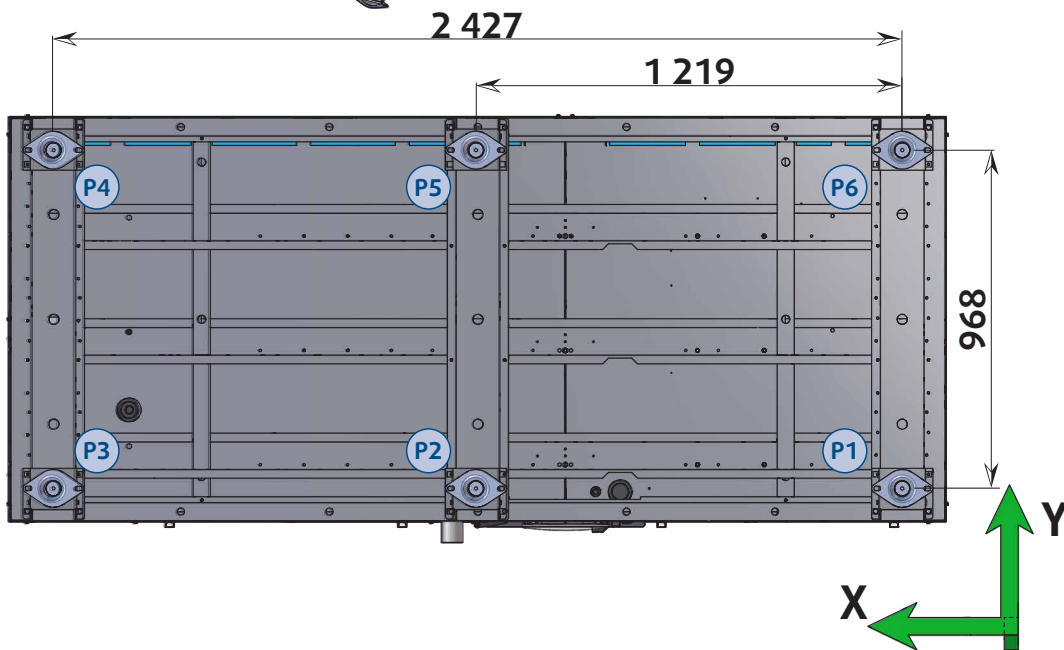

	M*	XG	YG	ZG	P1	P2	P3	P4	P5	P6
	kg	mm	mm	mm	kg	kg	kg	kg	kg	kg
45	1 010	1 450	480	650	183	207	230	163	140	116
55	1 010	1 450	480	650	183	207	230	163	140	116
65	1 080	1 450	480	700	200	193	262	175	131	138
75	1 080	1 450	480	700	200	193	262	175	131	138
90	1 260	1 350	480	800	254	256	259	176	173	171
105	1 370	1 350	480	800	275	278	281	191	188	185
125	1 390	1 350	480	800	279	282	285	194	191	188

* Operating weight

Systemair AC SAS · route de Verneuil, 27570 Tillières-sur- Avre · Tél. 02 32 60 61 00 · Fax 02 32 32 55 13
www.systemair.fr

