

**TSO-F**  
Supply Diffuser  
Handbook



# Table of Contents

Description . . . . .	.3
Setup Possibilities . . . . .	.5
Dimensions & Weights . . . . .	.6
Ordering Codes . . . . .	.7
Accessories . . . . .	.8
Technical Parameters . . . . .	.17
Installation . . . . .	.33
Transport, Storage and Operation . . . . .	.47
Supplement . . . . .	.48



## Description

TSO-F is a square perforated diffuser for installation in T-bar suspended ceilings. It is mainly intended for air supply and can be used for air extract as well. The recommended installation height is up to 4 m. The field of application is offices, schools, medical premises, shops, halls and corridors.

### Highlights

- Simple and safe design, easy installation and handling
- Operable also without plenum box, connected directly to duct bend or tee
- Low installation space height requirements
- Hidden deflector for omni-directional or restricted angle horizontal air discharge
- Well balanced ratio between air flow capacity, pressure drop and sound generation

### Accessories:

- THOR-F: Plenum Box
- THOR: Plenum Box
- THOR-E: Plenum Box
- CBO: Connection Box

## Design

The TSO-F is made from galvanized steel sheet with powder paint surface finish. It consists of the backing box with circular duct connection equipped by rubber gasket and the perforated front plate. An adjustable deflector is attached to the backing box by thread bolts. The outer shape of the backing box fits into T-bar ceiling frames with raster 600 mm or 625 mm. The front plate holds in the backing box by simple hinges on one side and by spring fixing brackets on the other side. The front plate can be opened or detached easily without tools. To prevent the free fall of the front plate during manipulation on the diffuser a safety string connects it detachably to the backing box. For easy opening of the front plate without tools there is a folding ear on the edge of the plate.

**Product Parts**

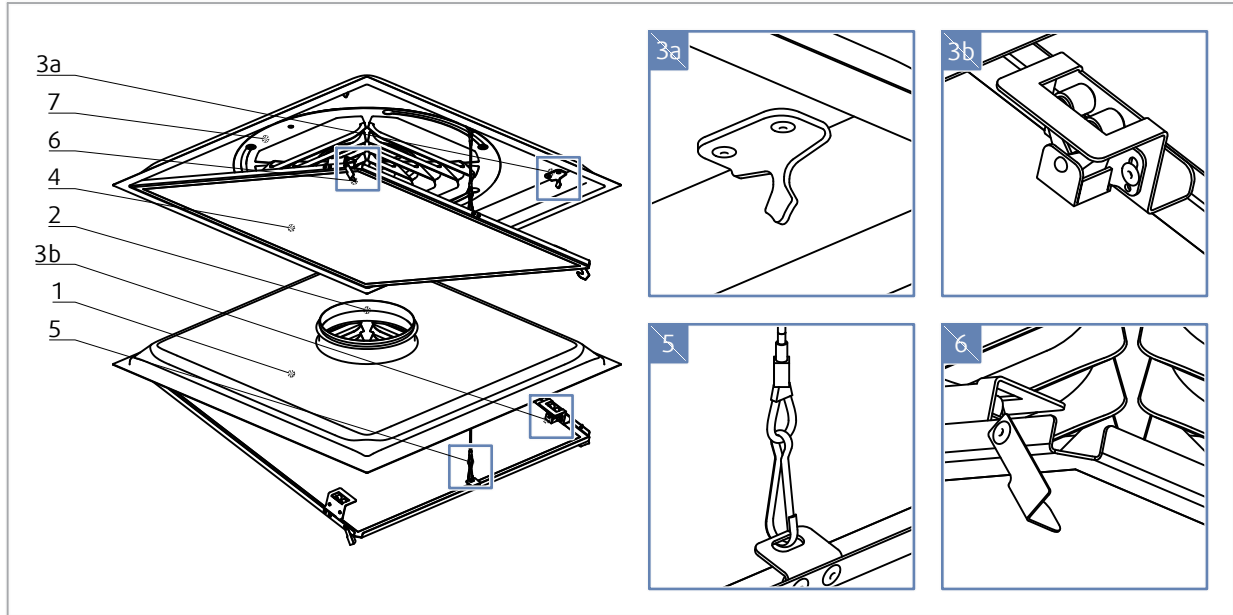

**Legend**

- 1** Backing box
- 2** Connection with rubber gasket
- 3** Spring clips for diffuser plate fixing (inside the backing box)
- 4** Diffuser plate
- 5** Safety cable (inside the backing box)
- 6** Commissioning tubes pull cut-outs
- 7** Deflectors



### Setup Possibilities

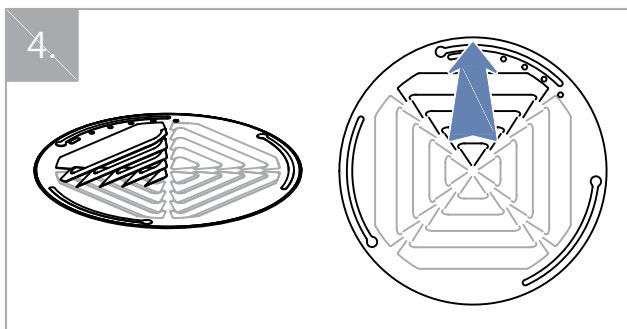
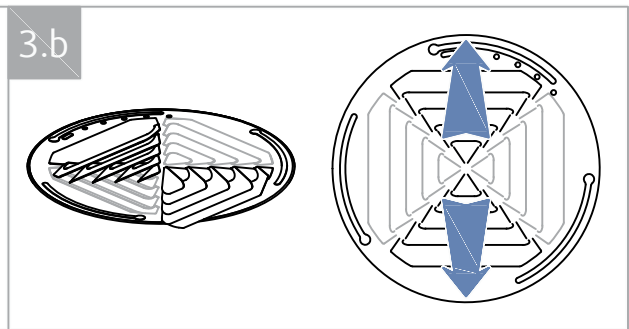
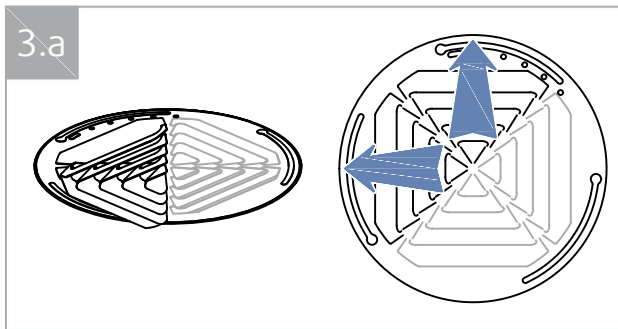
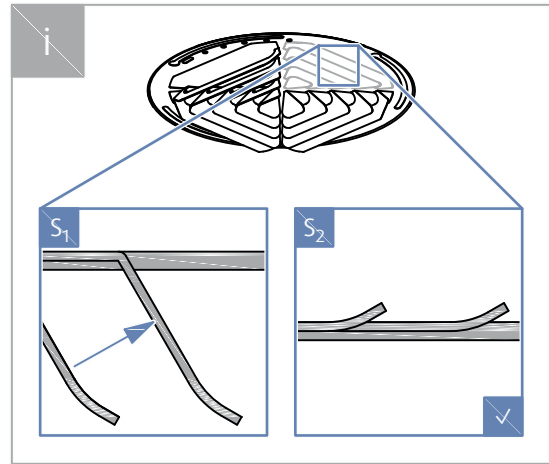
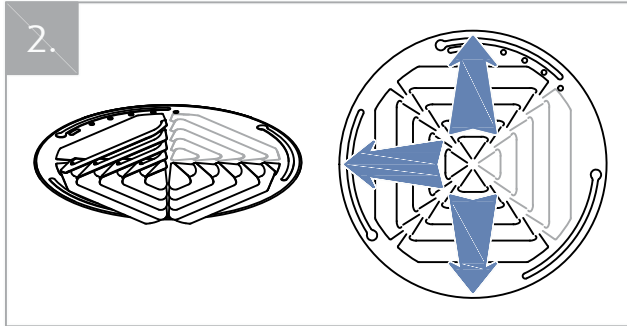
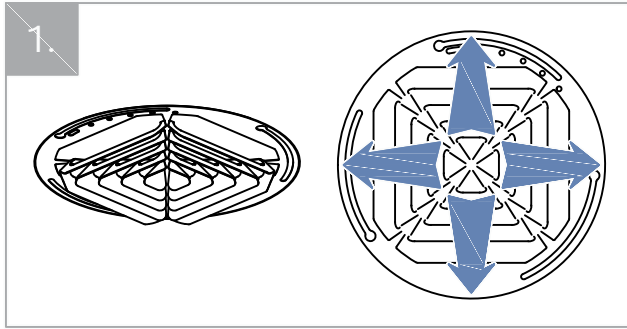

# Dimensions & Weights

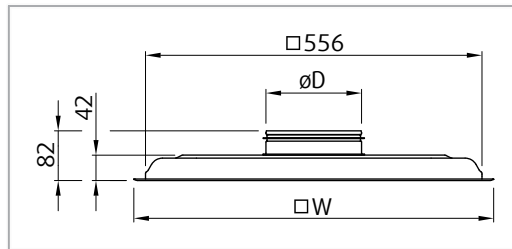

TSO-F	DN	øD	□W	m
	mm			kg
125	123	595	5,3	
		620	5,4	
160	158	595	5,3	
		620	5,4	
200	198	595	5,3	
		620	5,4	
250	248	595	5,2	
		620	5,4	
315	313	595	5,1	
		620	5,3	

# Ordering Codes

Size - inlet  $\varnothing$  (mm)

125

160

200

250

315

T-bar ceiling raster (mm)

600

625

Surface finish

**SW** Signal white (RAL9003, gloss 30%)

**RALxxxx** Other colour powder coating

Example of the Ordering Code

**TSO-F-250-600**

Diffuser of connection size 250 mm, for T-bar ceiling with raster 600mm, signal white RAL9003

Notes: If no surface finish is stated in ordering code, the product will be delivered in signal white RAL9003.

# Accessories

## THOR-F

Plenum Box



### Description

The THOR-F plenum box is used together with air diffusers for pressure reduction, airflow balancing and sound attenuation as well as for measuring and adjusting the air flow. The plenum box can be used for air inlet and extract.

### Design

THOR-F plenum boxes are manufactured from hot-dip galvanized sheet steel with inlet connection sleeve fitted with a rubber seal tested for air-tightness. The inlet is equipped by the damper with impulse tubes for measuring differential pressure for flow volume calculation, using a portable measuring device. It can be adjusted manually using a cable gearing.

## Dimensions

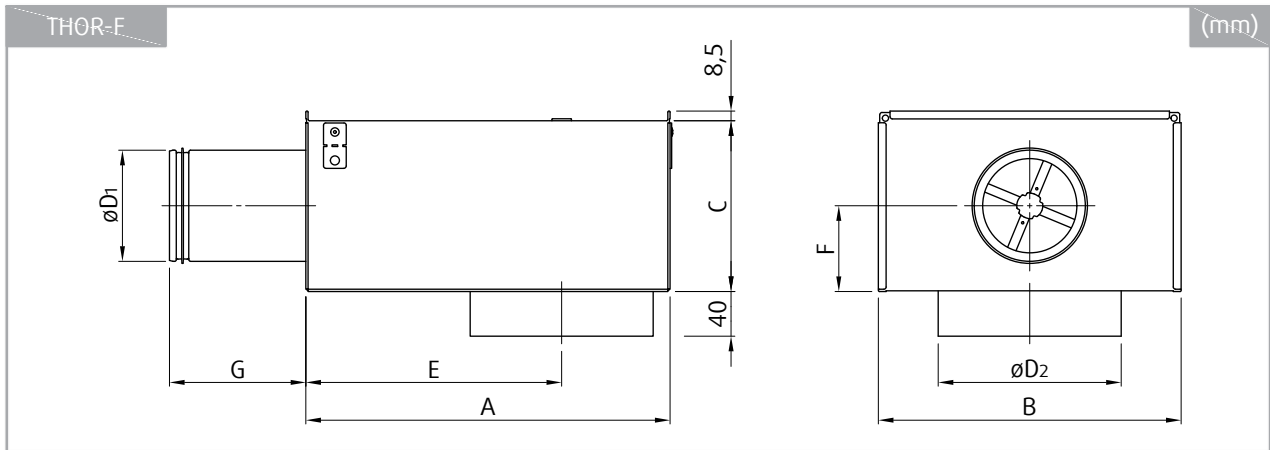

THOR-F	A	B	C	$\varnothing D_1$	$\varnothing D_2$	E	F	G	m
	mm								kg
100-125	320	267	150	98	125	243	75	132	3,8
100-160	320	267	150	98	160	225	75	132	3,8
125-200	360	267	160	123	200	245	80	147	4,4
160-250	450	317	195	158	250	310	98	162	6,1
200-315	500	367	250	198	315	328	125	172	8,0

## Ordering Codes

## Nominal size: Inlet-Outlet

100-125

100-160

125-200

160-250

200-315

## Example of the Ordering Code

THOR-F-100-125

Plenum box THOR-F with 100 mm circular inlet and 125 mm circular outlet (nominal dimensions).

## THOR

### Plenum Box

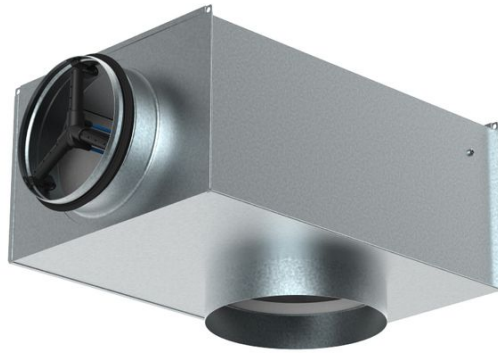

### Description

The THOR plenum box is used together with air diffusers for pressure reduction, airflow balancing and sound attenuation as well as for measuring and adjusting the air flow. The plenum box can be used for air inlet and extract.

### Design

THOR plenum boxes are manufactured from hot-dip galvanized sheet steel with inlet connection sleeve fitted with a rubber seal tested for air-tightness. The inlet is equipped by the ZEUS damper with impulse tubes for measuring differential pressure for flow volume calculation, using a portable measuring device. It can be adjusted manually using a cable gearing.

## Dimensions

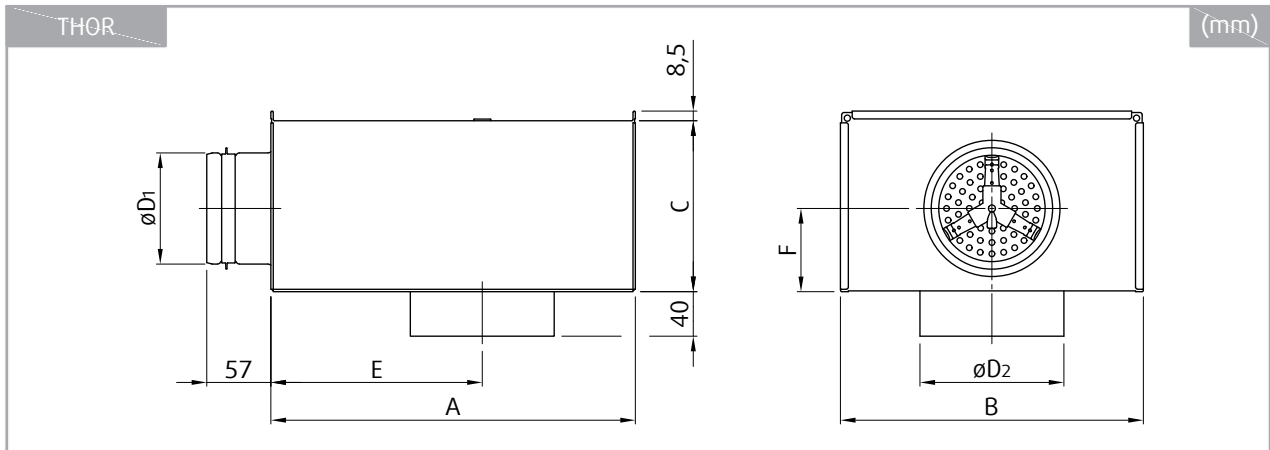

THOR	A	B	C	$\varnothing D_1$	$\varnothing D_2$	E	F	m
	mm							
100-125	320	267	150	98	126	185	75	2,5
125-160	360	267	160	123	161	210	80	2,9
160-200	450	317	195	158	201	280	98	4,0
200-250	500	367	250	198	251	305	125	5,4
250-315	565	467	300	248	316	330	150	7,3



### Ordering Codes

#### Nominal size: Inlet-Outlet

100-125

125-160

160-200

200-250

250-315

#### Example of the Ordering Code

THOR-100-125

Plenum box THOR with 100 mm circular inlet and 125 mm circular outlet (nominal dimensions).

## THOR-E

### Plenum Box



### Description

The THOR-E plenum box is used together with air diffusers for pressure reduction, airflow balancing and sound attenuation as well as for adjusting the air flow. The plenum box can be used for air supply and extract.

### Design

THOR-E plenum boxes are manufactured from hot-dip galvanized sheet steel with inlet connection sleeve without gasket. The inlet can be equipped by a simple sheet metal damper that is adjustable by pull-ropes from outside.

## Dimensions

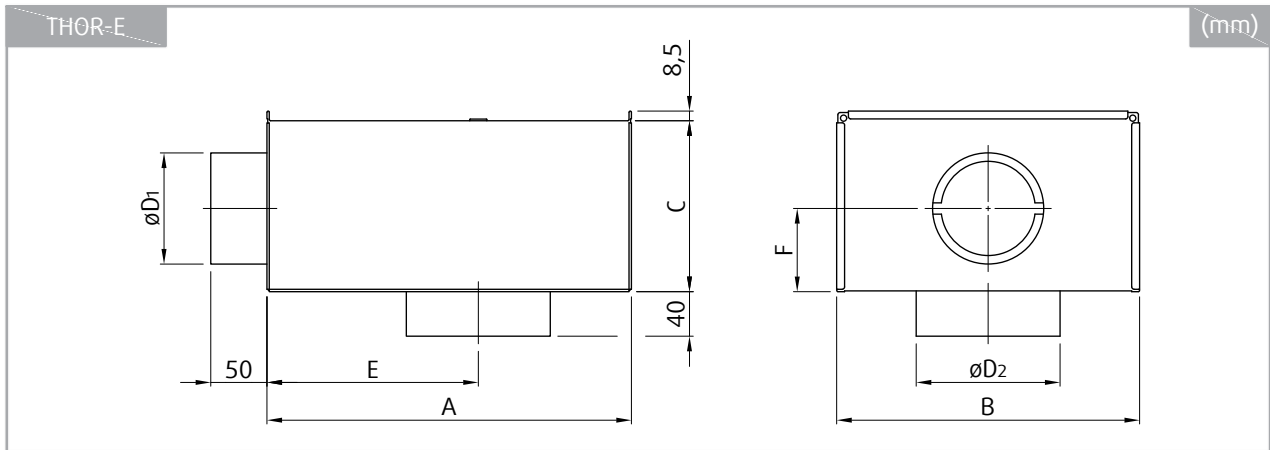

THOR-E	A	B	C	$\varnothing D_1$	$\varnothing D_2$	E	F	m
	mm							kg
100-125	320	267	150	98	126	185	75	2,3
125-160	360	267	160	123	161	210	80	2,6
160-200	450	317	195	158	201	280	98	3,7
200-250	500	367	250	198	251	305	125	4,9
250-315	565	467	300	248	316	330	150	6,9

## Ordering Codes

## Nominal size: Inlet-Outlet

100-125

125-160

160-200

200-250

250-315

## Damper

**D1** Adjustment damper

- Without damper

## Example of the Ordering Code

THOR-E-100-125-D1

Plenum box THOR-E with 100 mm circular inlet and 125 mm circular outlet (nominal dimensions) with damper.

## CBO

Connection Box



### Description

CBO is a connection box for the diffusers. It is recommended for use in installations with limited vertical space. It connects the diffuser with the horizontal duct so that the needed installation space height is less than 285 mm for the largest nominal size.

### Design

CBO is made from galvanized steel sheet. It has an immersed circular connection with nominal size for the diffuser. The duct connection of larger nominal sizes has oval shape that reduces the required installation height profile.

## Dimensions

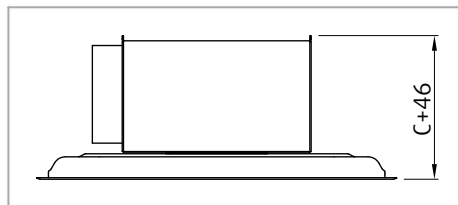
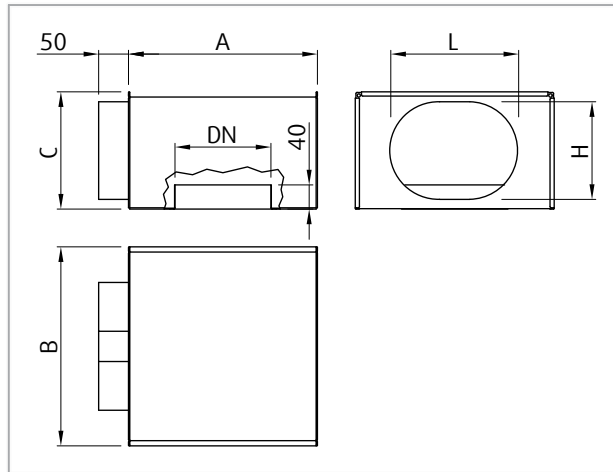

CBO	DN	A	B	C	L	H	m
	mm						kg
	125	212	196	158	ø123		1,3
	160	247	231	193	ø158		1,8
	200	287	271	233	ø198		2,4
	250	337	319	233	277	198	2,9
	315	402	421	233	379	198	3,9

## Ordering Codes

Nominal outlet size  $\varnothing$  (mm)

125

160

200

250

315

## Example of the Ordering Code

CBO-125

Connection box CBO with 125 mm circular outlet (nominal dimensions).

# Technical Parameters

## Legend

$p_s$  (Pa) Pressure drop

$q_v$  (m<sup>3</sup>/h or l/s) Air flow volume

$L_{WA}$  (dB(A)) A-weighted total radiated sound power level

$L_{pA}$  (dB(A)) A-weighted total sound pressure level expressed for 10 m<sup>2</sup> room absorption area

$L_W$  (dB) Non weighted total sound power level

$L_{0,2}$  (m) Air throw length with terminal velocity 0,2 m/s

$L_x$  (m) Air throw length calculated for specific terminal velocity

$x$  (m/s) Terminal velocity in range of 0,1 m/s ... 1 m/s

**0%, 20%, 40%, 60%, 80%, 100%** The plenum box damper positions in pressure drop/noise diagrams are represented as percentage. In case of THOR-E, 0% is fully closed damper. In case of THOR-F and THOR, 20% is fully closed damper. 100% is fully open damper.

## Calculation of Air Throw for Different Terminal Velocities

$$L_x = L_{0,2} \cdot 0,2/x$$

Pressure drop and radiated sound power level dependent on air flow volume. Connected directly to the duct.  
 Throw length with terminal velocity 0,2 m/s dependent on air flow volume.

**TSO-F-125-600-SW**

Pressure drop & A-weighted sound power level in dB(A)

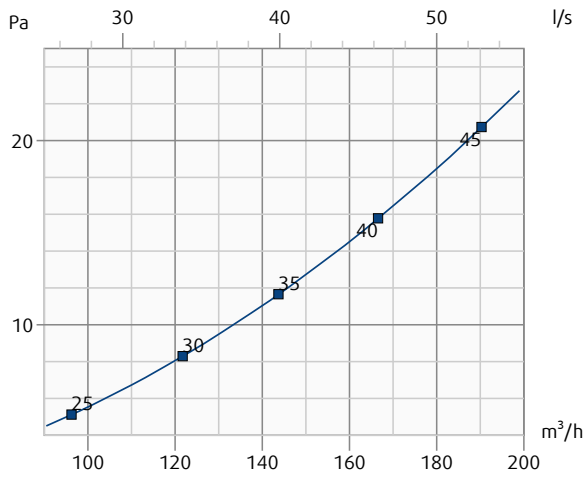

**TSO-F-160-600-SW**

Pressure drop & A-weighted sound power level in dB(A)

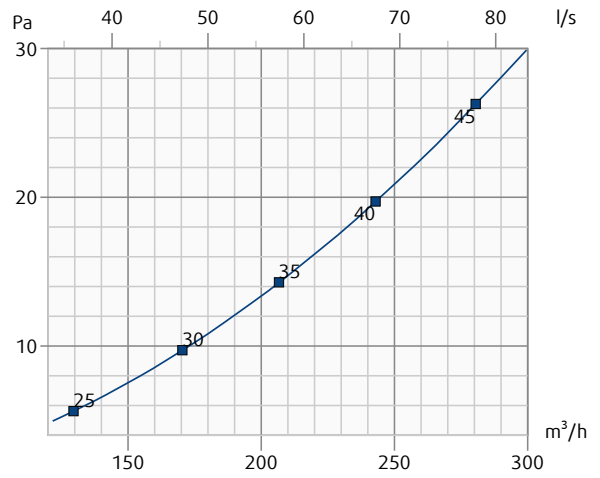

**TSO-F-125-600-SW**

Throw length (terminal velocity 0.2 m/s)

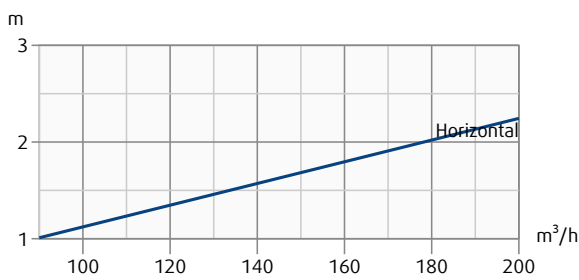

**TSO-F-160-600-SW**

Throw length (terminal velocity 0.2 m/s)

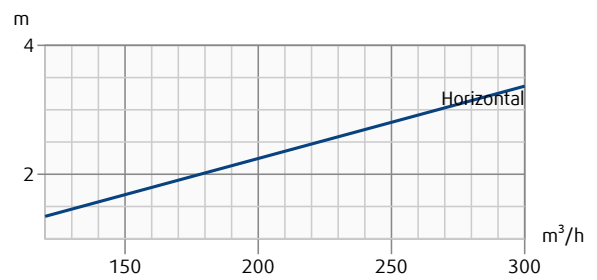



Pressure drop and radiated sound power level dependent on air flow volume. Connected directly to the duct.  
 Throw length with terminal velocity 0,2 m/s dependent on air flow volume.

**TSO-F-200-600-SW**

Pressure drop & A-weighted sound power level in dB(A)

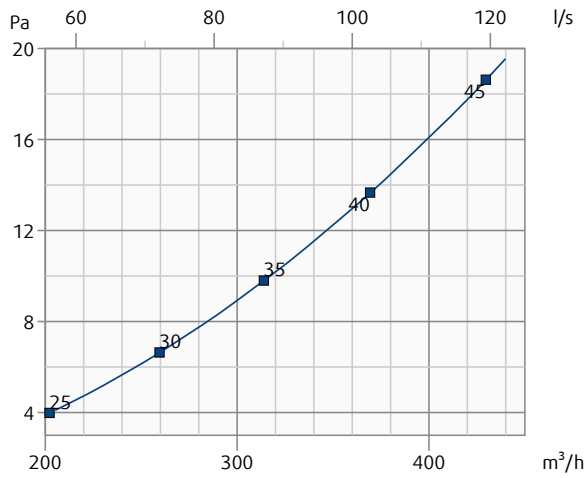

**TSO-F-250-600-SW**

Pressure drop & A-weighted sound power level in dB(A)

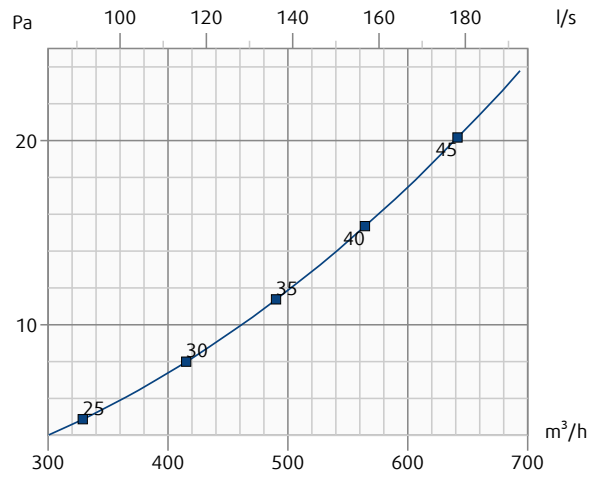

**TSO-F-200-600-SW**

Throw length (terminal velocity 0.2 m/s)

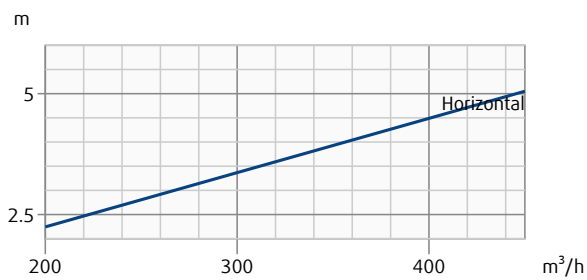

**TSO-F-250-600-SW**

Throw length (terminal velocity 0.2 m/s)

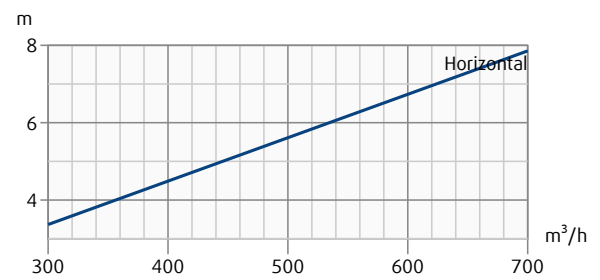

Pressure drop and radiated sound power level dependent on air flow volume. Connected directly to the duct.  
 Throw length with terminal velocity 0,2 m/s dependent on air flow volume.

**TSO-F-315-600-SW**

Pressure drop & A-weighted sound power level in dB(A)

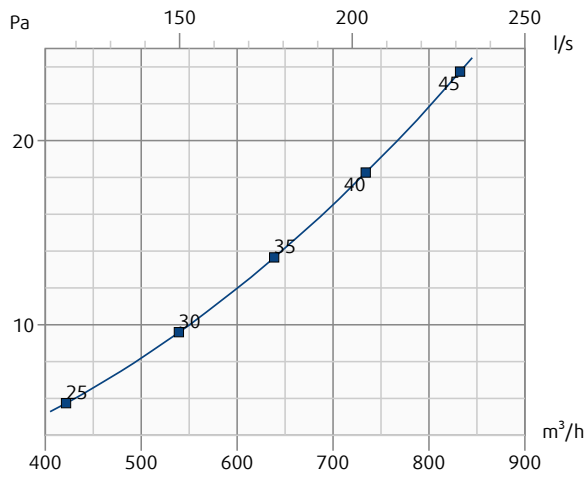

**TSO-F-315-600-SW**

Throw length (terminal velocity 0.2 m/s)

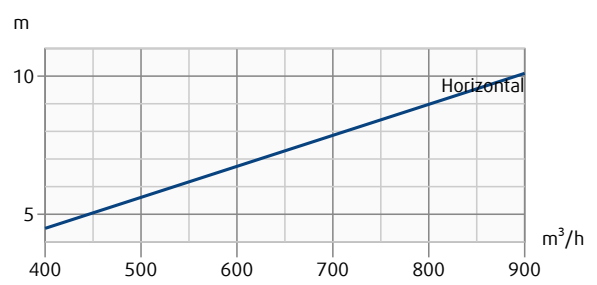

Pressure drop and radiated sound power level dependent on air flow volume, measured with THOR-F plenum box.  
 Throw length with terminal velocity 0,2 m/s dependent on air flow volume.

**TSO-F-125-600-SW + THOR-F-100-125**

Pressure drop & A-weighted sound power level in dB(A)

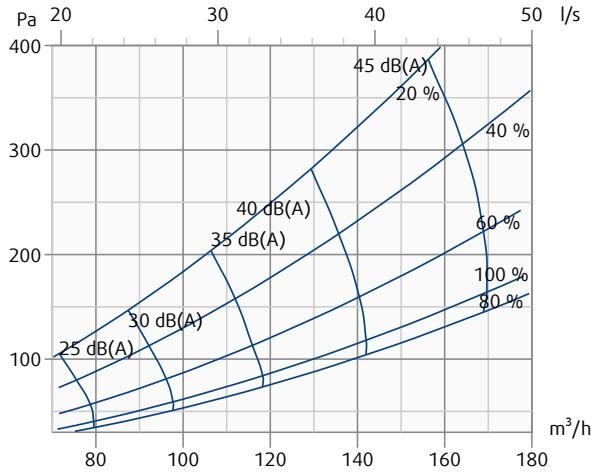

**TSO-F-160-600-SW + THOR-F-100-160**

Pressure drop & A-weighted sound power level in dB(A)

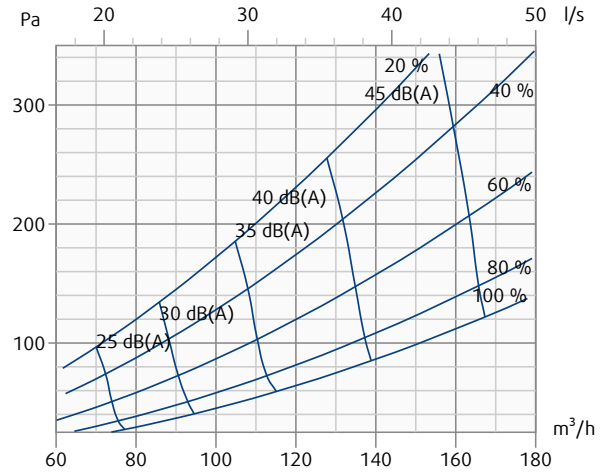

**TSO-F-125-600-SW + THOR-F-100-125**

Throw length (terminal velocity 0.2 m/s)

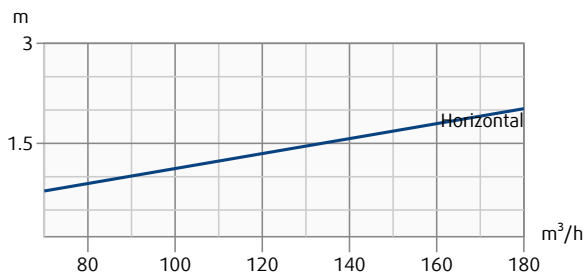

**TSO-F-160-600-SW + THOR-F-100-160**

Throw length (terminal velocity 0.2 m/s)

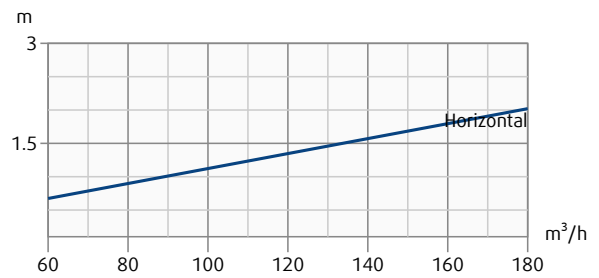

Pressure drop and radiated sound power level dependent on air flow volume, measured with THOR-F plenum box.  
 Throw length with terminal velocity 0,2 m/s dependent on air flow volume.

**TSO-F-200-600-SW + THOR-F-125-200**

Pressure drop & A-weighted sound power level in dB(A)

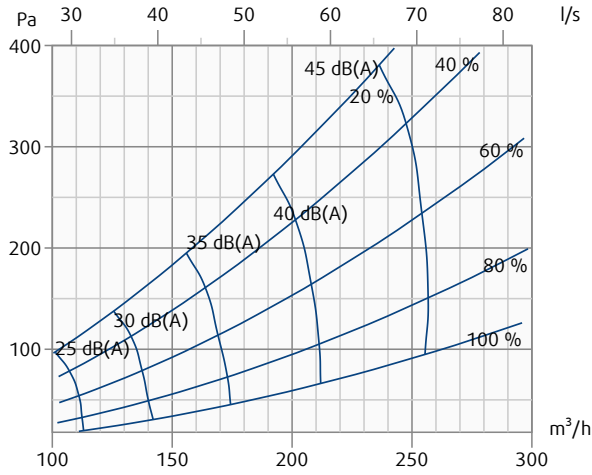

**TSO-F-250-600-SW + THOR-F-160-250**

Pressure drop & A-weighted sound power level in dB(A)

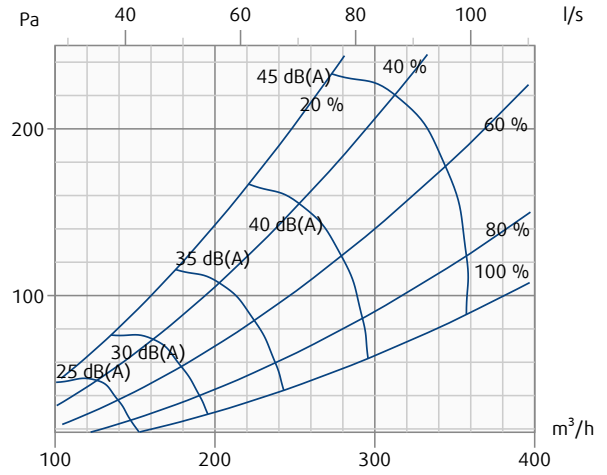

**TSO-F-200-600-SW + THOR-F-125-200**

Throw length (terminal velocity 0.2 m/s)

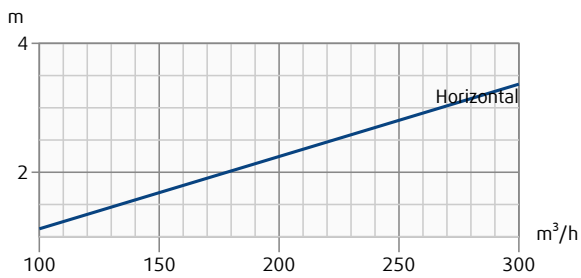

**TSO-F-250-600-SW + THOR-F-160-250**

Throw length (terminal velocity 0.2 m/s)

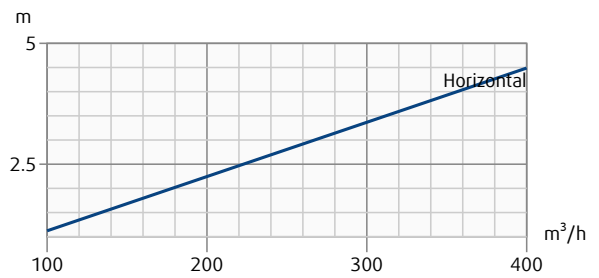

Pressure drop and radiated sound power level dependent on air flow volume, measured with THOR-F plenum box.  
 Throw length with terminal velocity 0,2 m/s dependent on air flow volume.

**TSO-F-315-600-SW + THOR-F-200-315**

Pressure drop & A-weighted sound power level in dB(A)

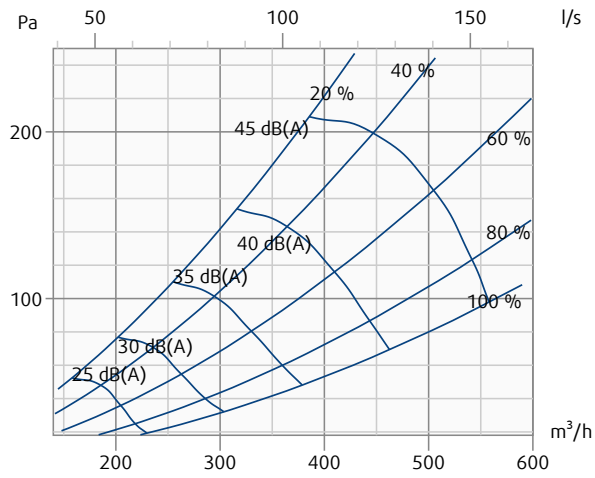

**TSO-F-315-600-SW + THOR-F-200-315**

Throw length (terminal velocity 0.2 m/s)

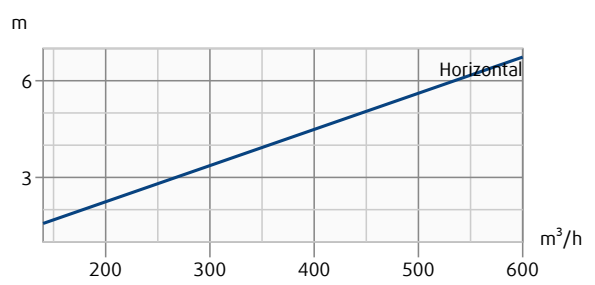

Pressure drop and radiated sound power level dependent on air flow volume, measured with THOR plenum box.  
 Throw length with terminal velocity 0,2 m/s dependent on air flow volume.

**TSO-F-125-600-SW + THOR-100-125**

Pressure drop & A-weighted sound power level in dB(A)

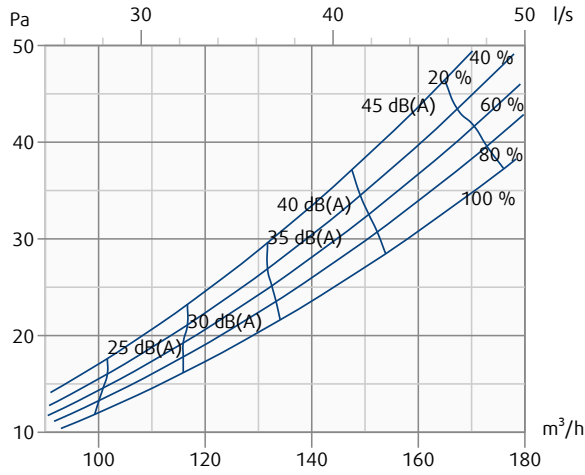

**TSO-F-160-600-SW + THOR-125-160**

Pressure drop & A-weighted sound power level in dB(A)

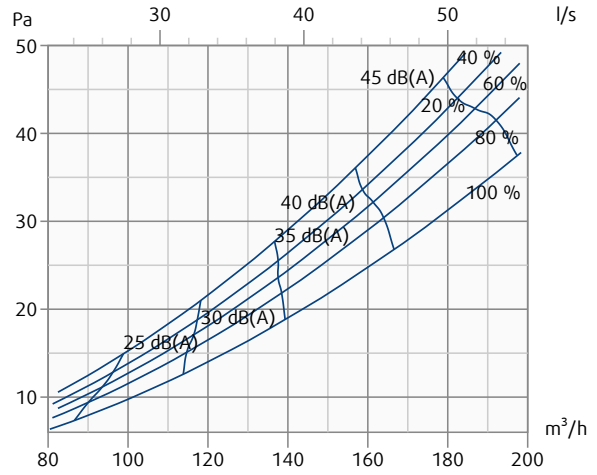

**TSO-F-125-600-SW + THOR-100-125**

Throw length (terminal velocity 0.2 m/s)

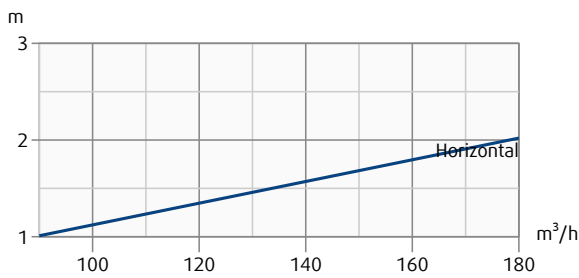

**TSO-F-160-600-SW + THOR-125-160**

Throw length (terminal velocity 0.2 m/s)

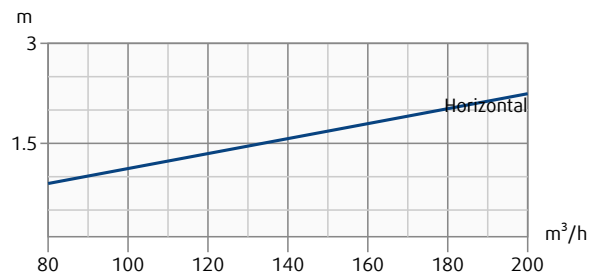

Pressure drop and radiated sound power level dependent on air flow volume, measured with THOR plenum box.  
 Throw length with terminal velocity 0,2 m/s dependent on air flow volume.

**TSO-F-200-600-SW + THOR-160-200**

Pressure drop & A-weighted sound power level in dB(A)

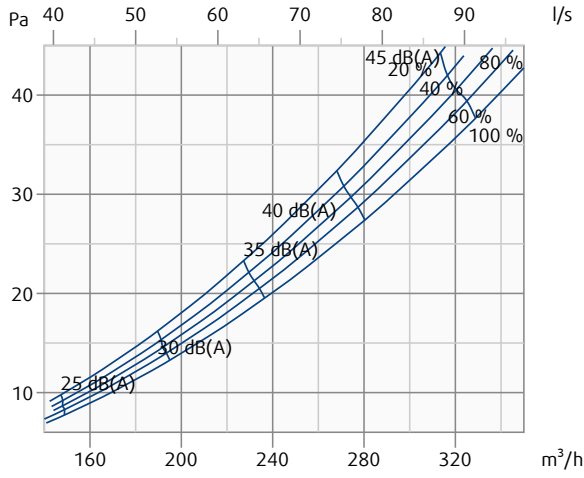

**TSO-F-250-600-SW + THOR-200-250**

Pressure drop & A-weighted sound power level in dB(A)

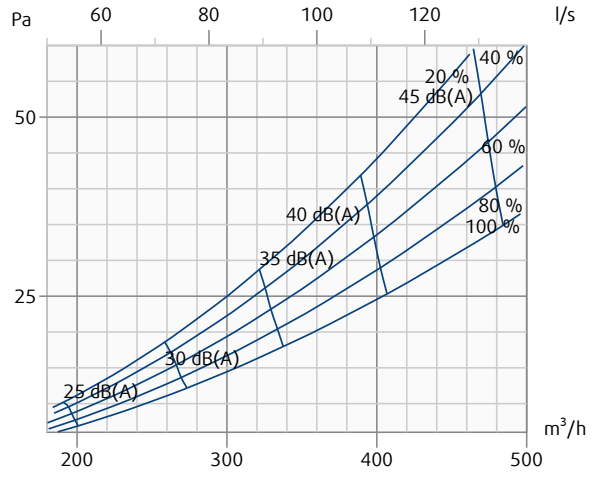

**TSO-F-200-600-SW + THOR-160-200**

Throw length (terminal velocity 0.2 m/s)

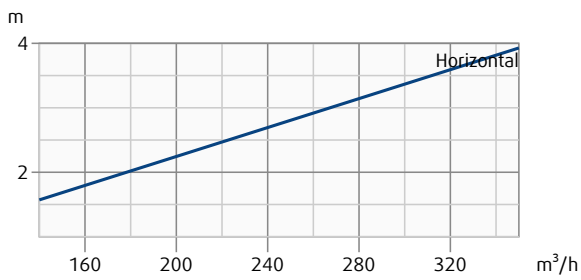

**TSO-F-250-600-SW + THOR-200-250**

Throw length (terminal velocity 0.2 m/s)

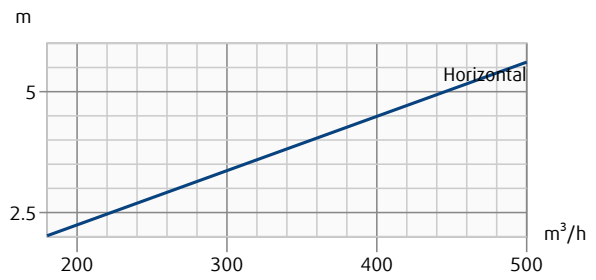



Pressure drop and radiated sound power level dependent on air flow volume, measured with THOR plenum box.  
 Throw length with terminal velocity 0,2 m/s dependent on air flow volume.

**TSO-F-315-600-SW + THOR-250-315**

Pressure drop & A-weighted sound power level in dB(A)

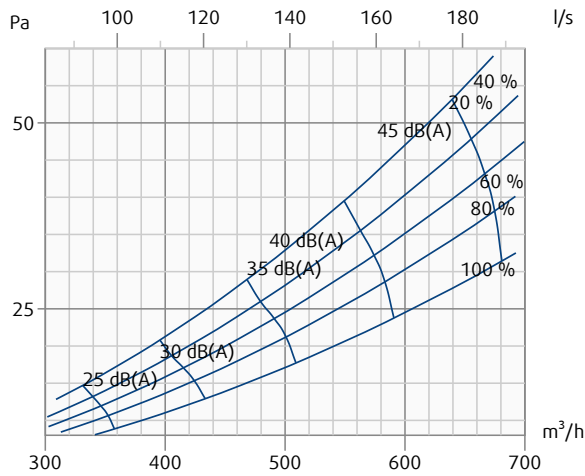

**TSO-F-315-600-SW + THOR-250-315**

Throw length (terminal velocity 0.2 m/s)

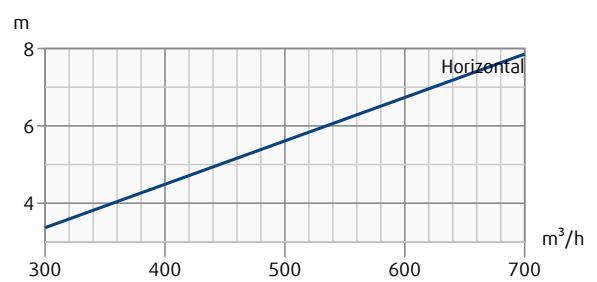

Pressure drop and radiated sound power level dependent on air flow volume, measured with THOR-E plenum box.  
 Throw length with terminal velocity 0,2 m/s dependent on air flow volume.

**TSO-F-125-600-SW + THOR-E-100-125**

Pressure drop & A-weighted sound power level in dB(A)

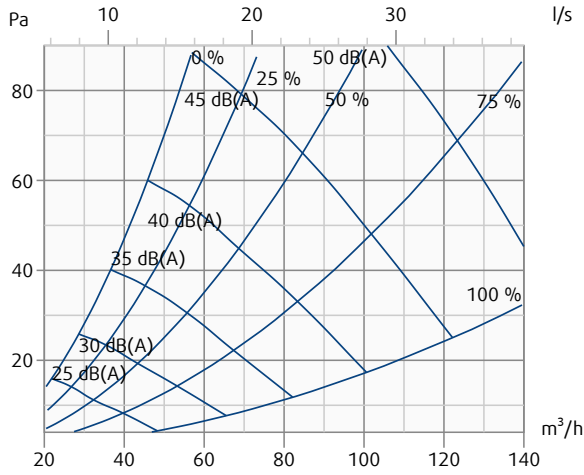

**TSO-F-160-600-SW + THOR-E-125-160**

Pressure drop & A-weighted sound power level in dB(A)

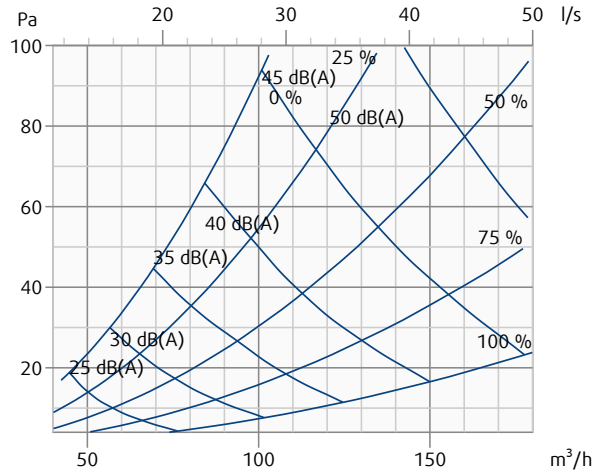

**TSO-F-125-600-SW + THOR-E-100-125**

Throw length (terminal velocity 0.2 m/s)

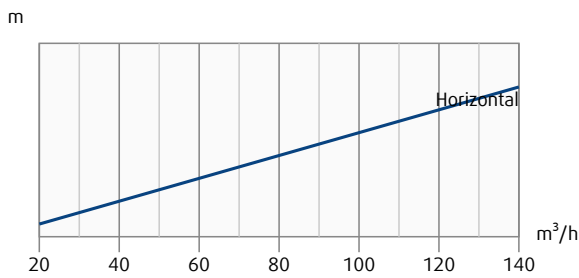

**TSO-F-160-600-SW + THOR-E-125-160**

Throw length (terminal velocity 0.2 m/s)

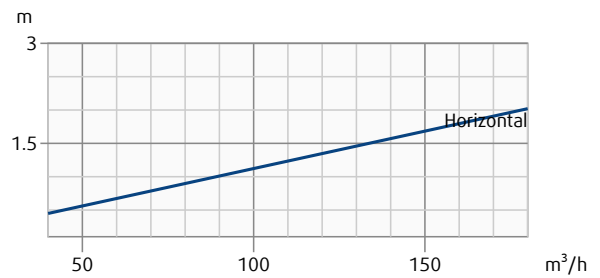

Pressure drop and radiated sound power level dependent on air flow volume, measured with THOR-E plenum box.  
 Throw length with terminal velocity 0,2 m/s dependent on air flow volume.

**TSO-F-200-600-SW + THOR-E-160-200**

Pressure drop & A-weighted sound power level in dB(A)

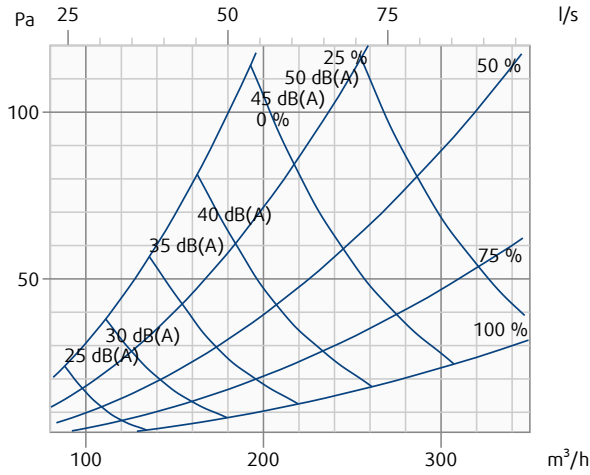

**TSO-F-250-600-SW + THOR-E-200-250**

Pressure drop & A-weighted sound power level in dB(A)

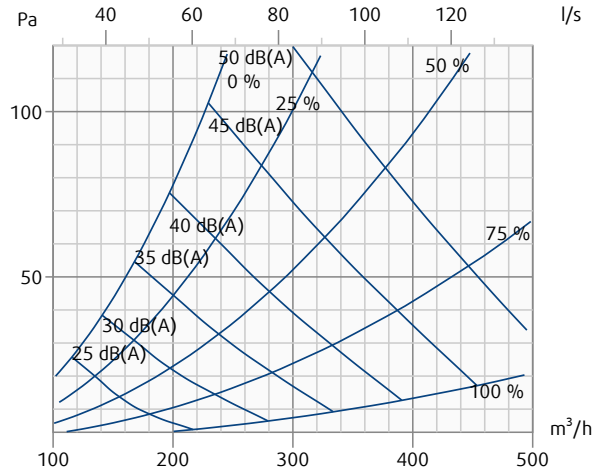

**TSO-F-200-600-SW + THOR-E-160-200**

Throw length (terminal velocity 0.2 m/s)

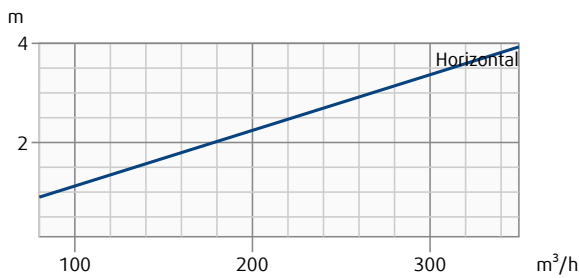

**TSO-F-250-600-SW + THOR-E-200-250**

Throw length (terminal velocity 0.2 m/s)

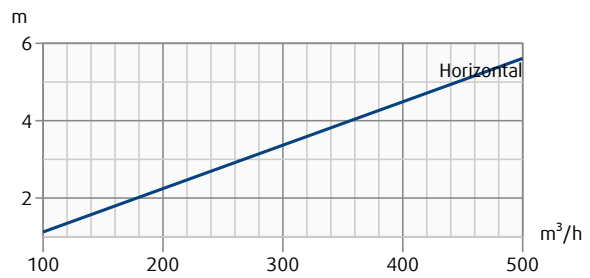

Pressure drop and radiated sound power level dependent on air flow volume, measured with THOR-E plenum box.  
 Throw length with terminal velocity 0,2 m/s dependent on air flow volume.

**TSO-F-315-600-SW + THOR-E-250-315**

Pressure drop & A-weighted sound power level in dB(A)

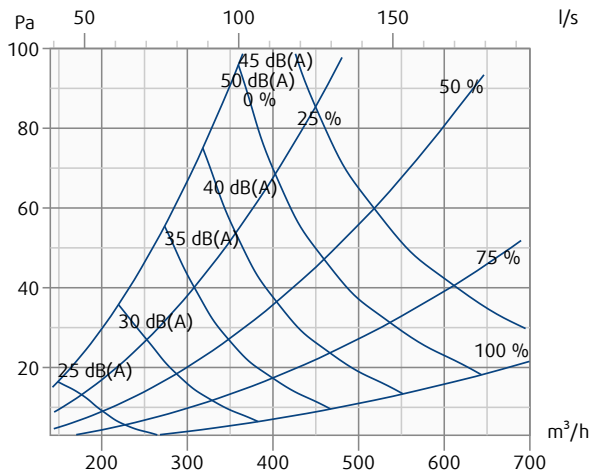

**TSO-F-315-600-SW + THOR-E-250-315**

Throw length (terminal velocity 0.2 m/s)

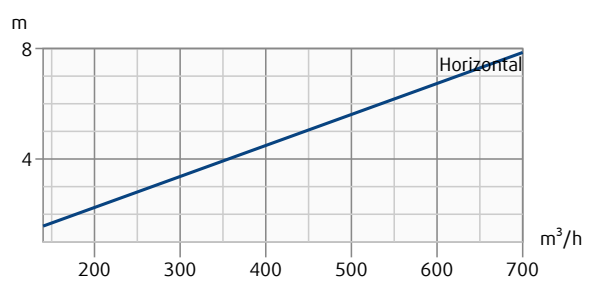

Pressure drop and radiated sound power level dependent on air flow volume, measured with CBO plenum box.  
 Throw length with terminal velocity 0,2 m/s dependent on air flow volume.

**TSO-F-125-600-SW + CBO-125**

Pressure drop & A-weighted sound power level in dB(A)

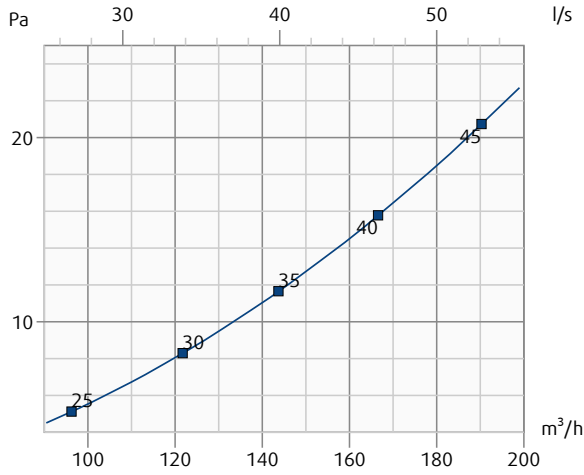

**TSO-F-160-600-SW + CBO-160**

Pressure drop & A-weighted sound power level in dB(A)

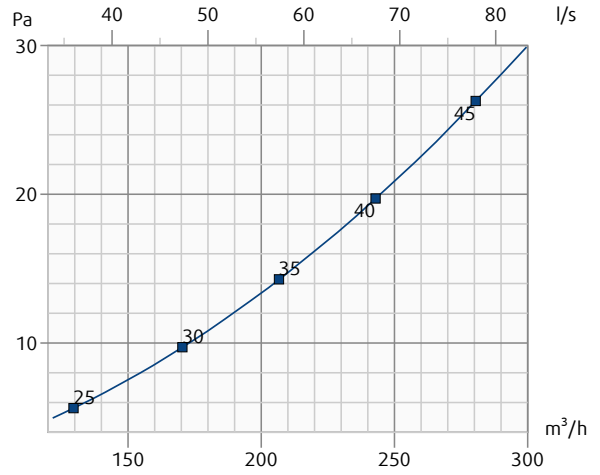

**TSO-F-125-600-SW + CBO-125**

Throw length (terminal velocity 0.2 m/s)

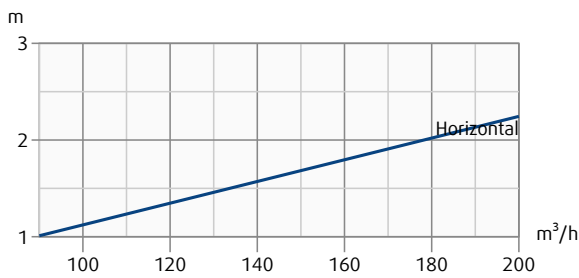

**TSO-F-160-600-SW + CBO-160**

Throw length (terminal velocity 0.2 m/s)

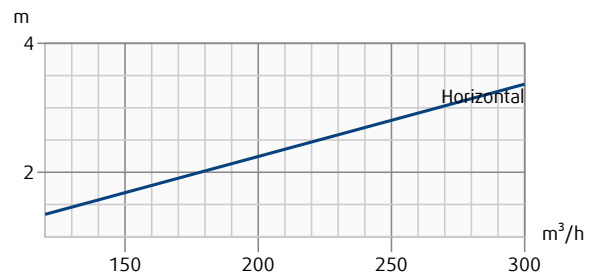

Pressure drop and radiated sound power level dependent on air flow volume, measured with CBO plenum box.  
 Throw length with terminal velocity 0,2 m/s dependent on air flow volume.

**TSO-F-200-600-SW + CBO-200**

Pressure drop & A-weighted sound power level in dB(A)

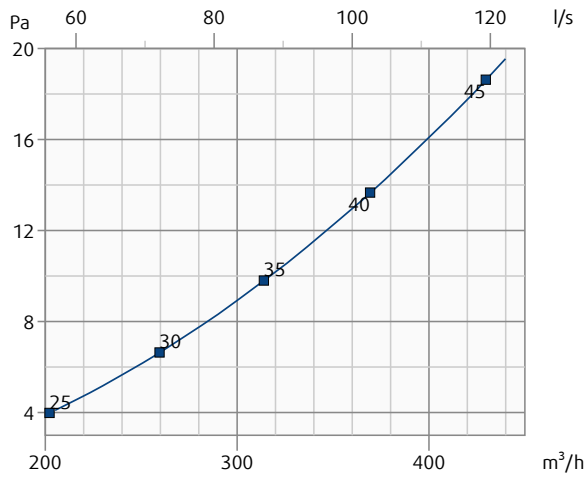

**TSO-F-250-600-SW + CBO-250**

Pressure drop & A-weighted sound power level in dB(A)

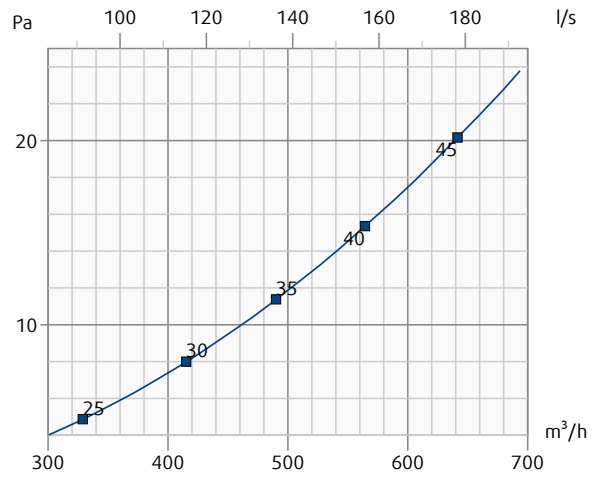

**TSO-F-200-600-SW + CBO-200**

Throw length (terminal velocity 0.2 m/s)

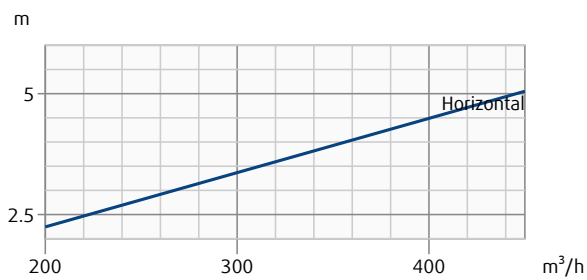

**TSO-F-250-600-SW + CBO-250**

Throw length (terminal velocity 0.2 m/s)

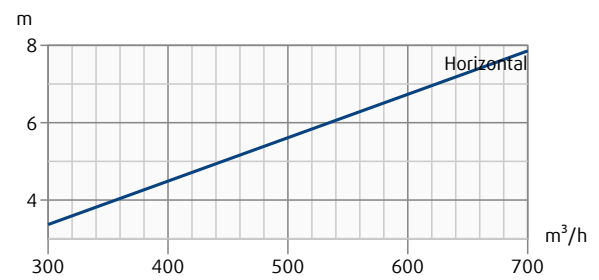

Pressure drop and radiated sound power level dependent on air flow volume, measured with CBO plenum box.  
 Throw length with terminal velocity 0,2 m/s dependent on air flow volume.

**TSO-F-315-600-SW + CBO-315**

Pressure drop & A-weighted sound power level in dB(A)

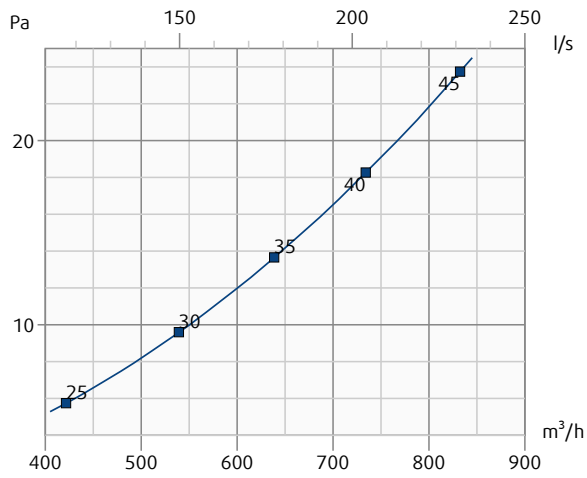

**TSO-F-315-600-SW + CBO-315**

Throw length (terminal velocity 0.2 m/s)

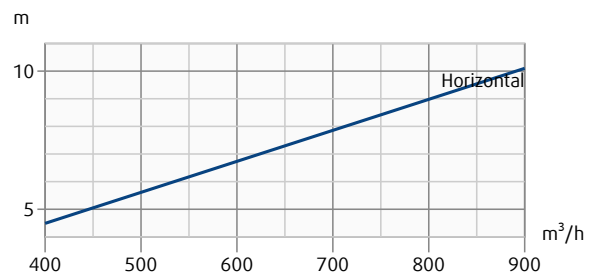



# Installation

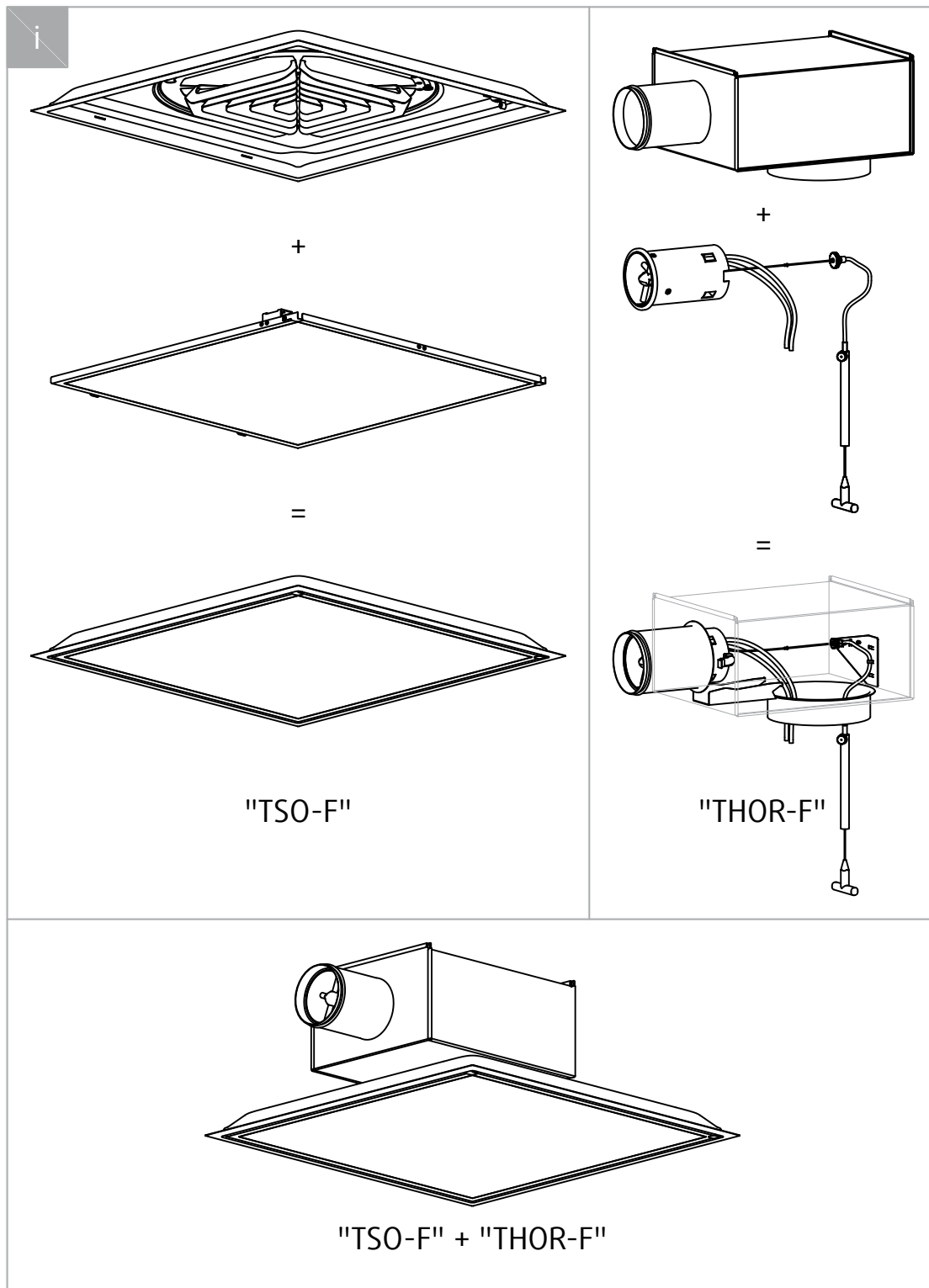

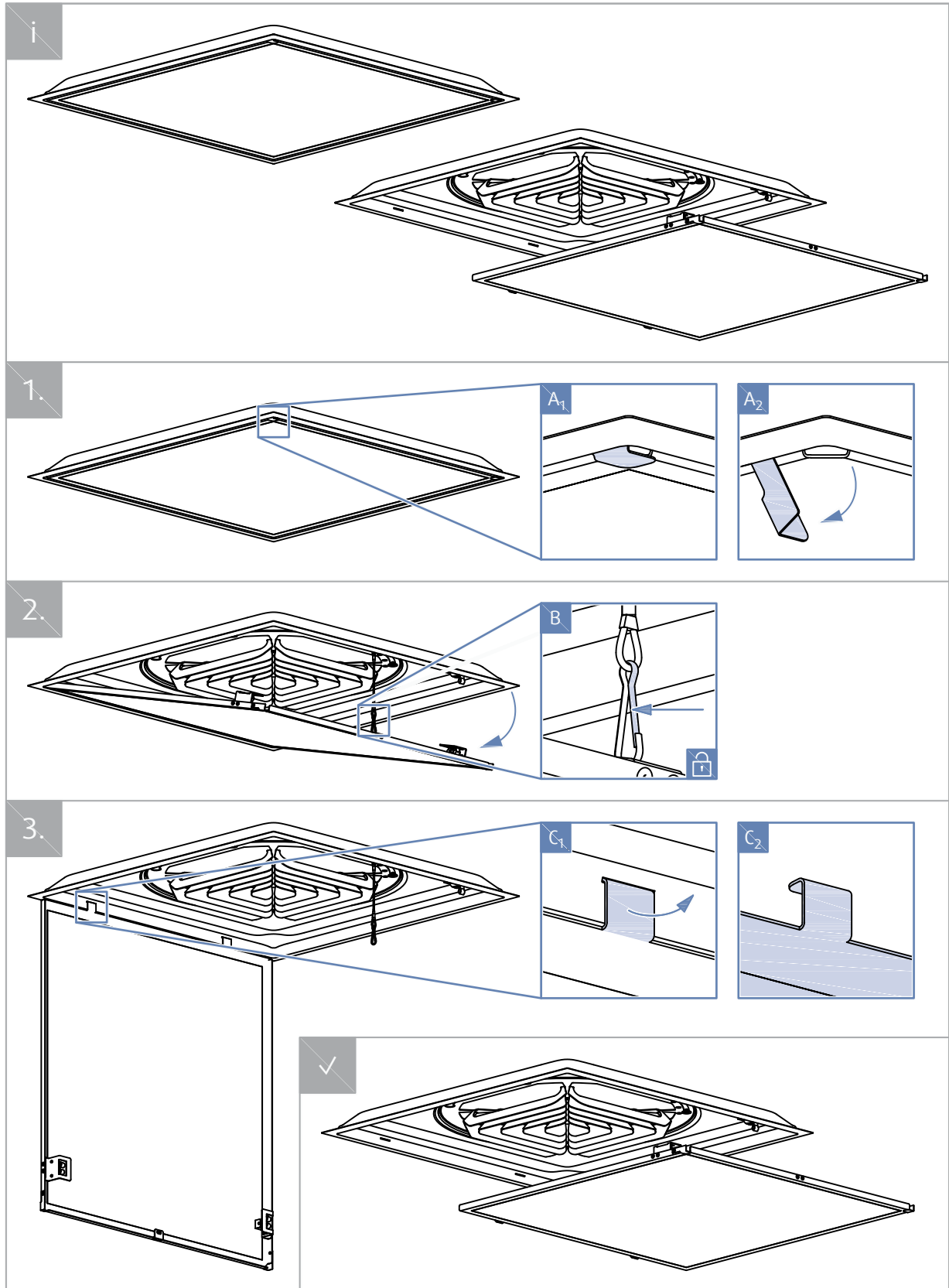

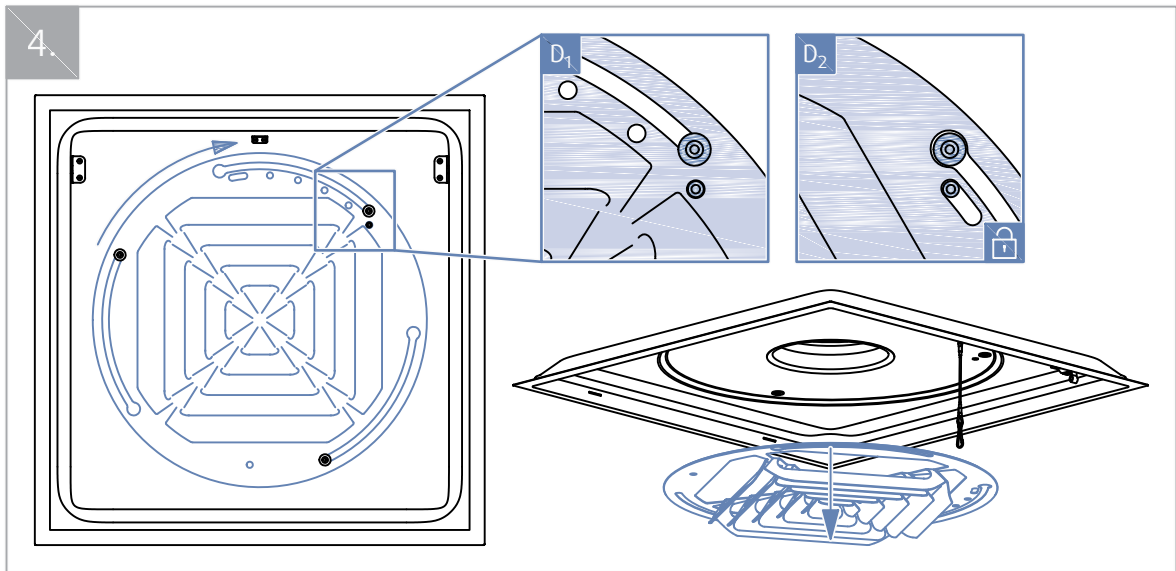

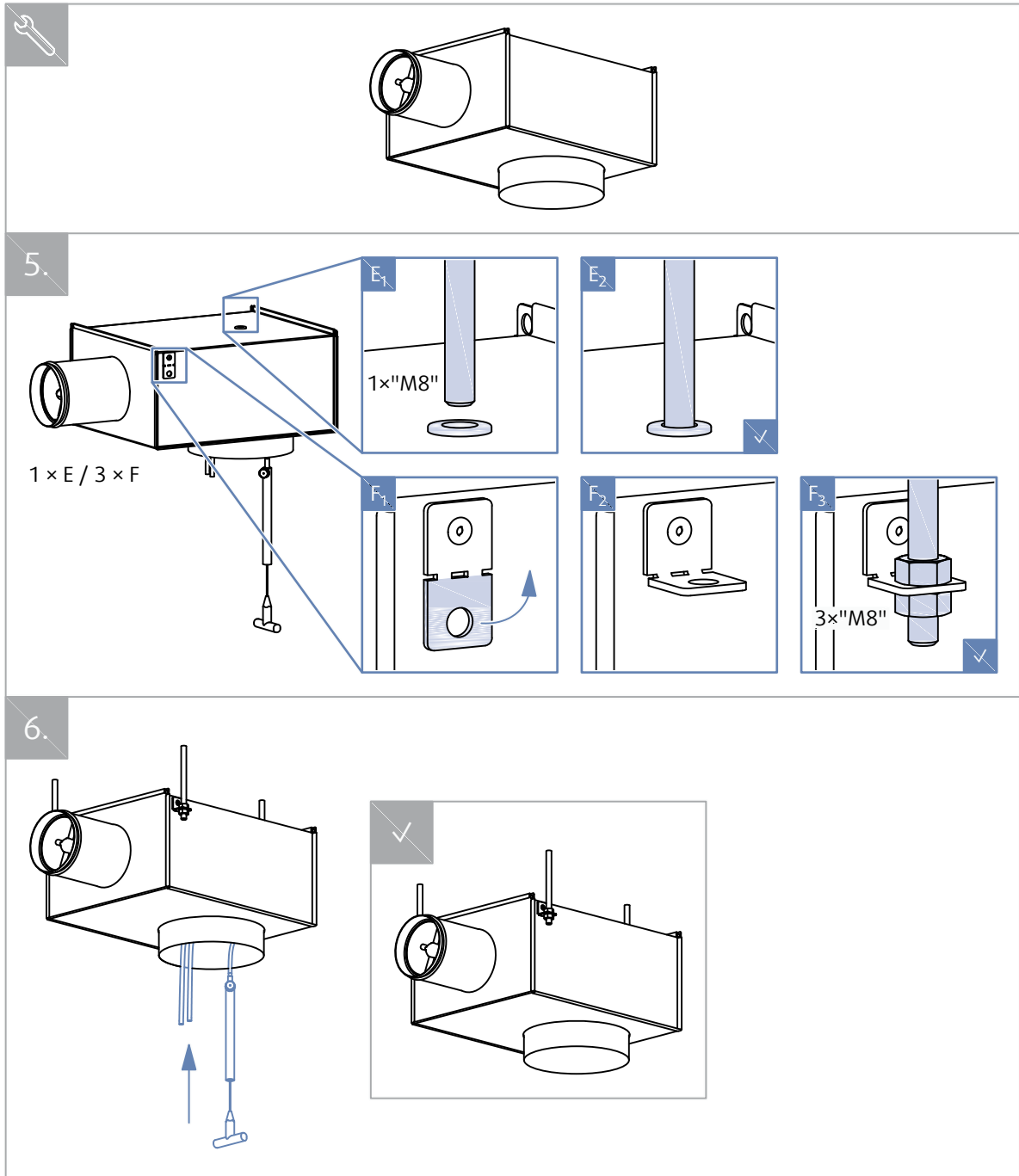

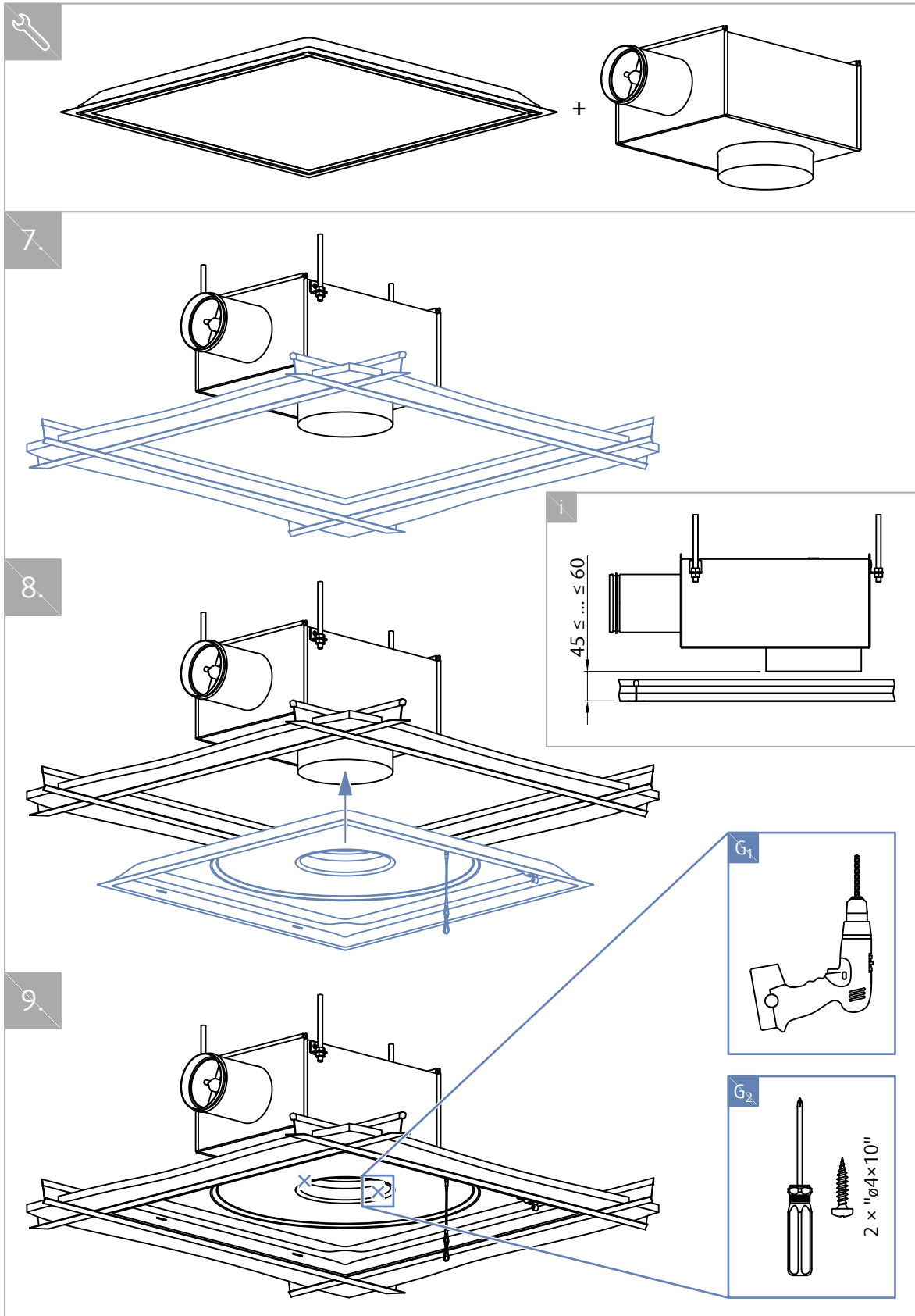

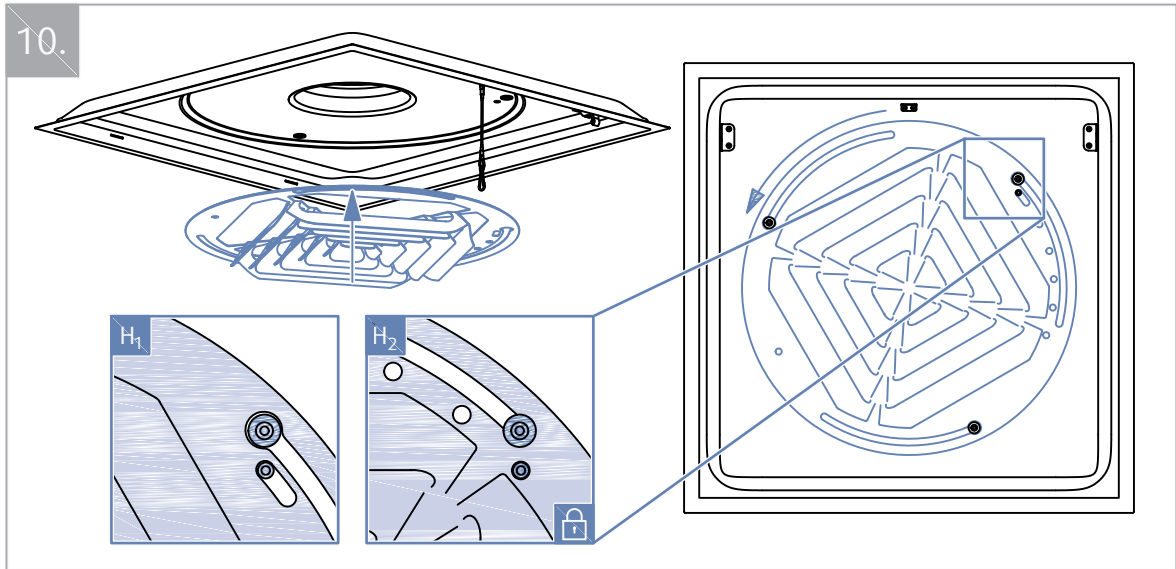

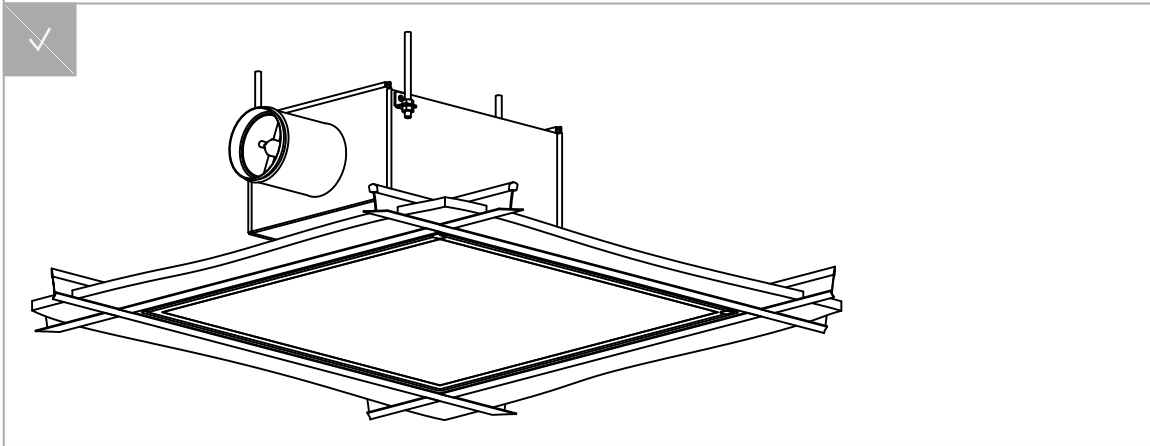
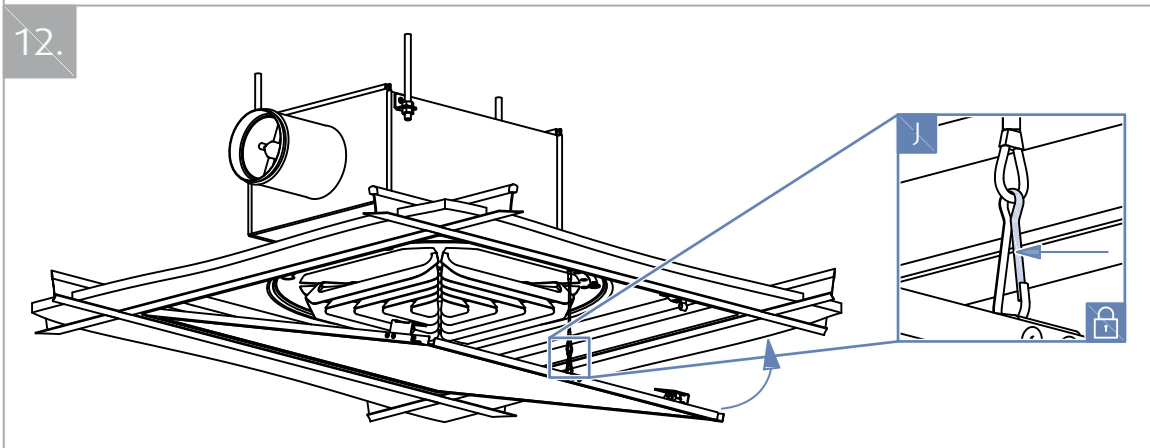
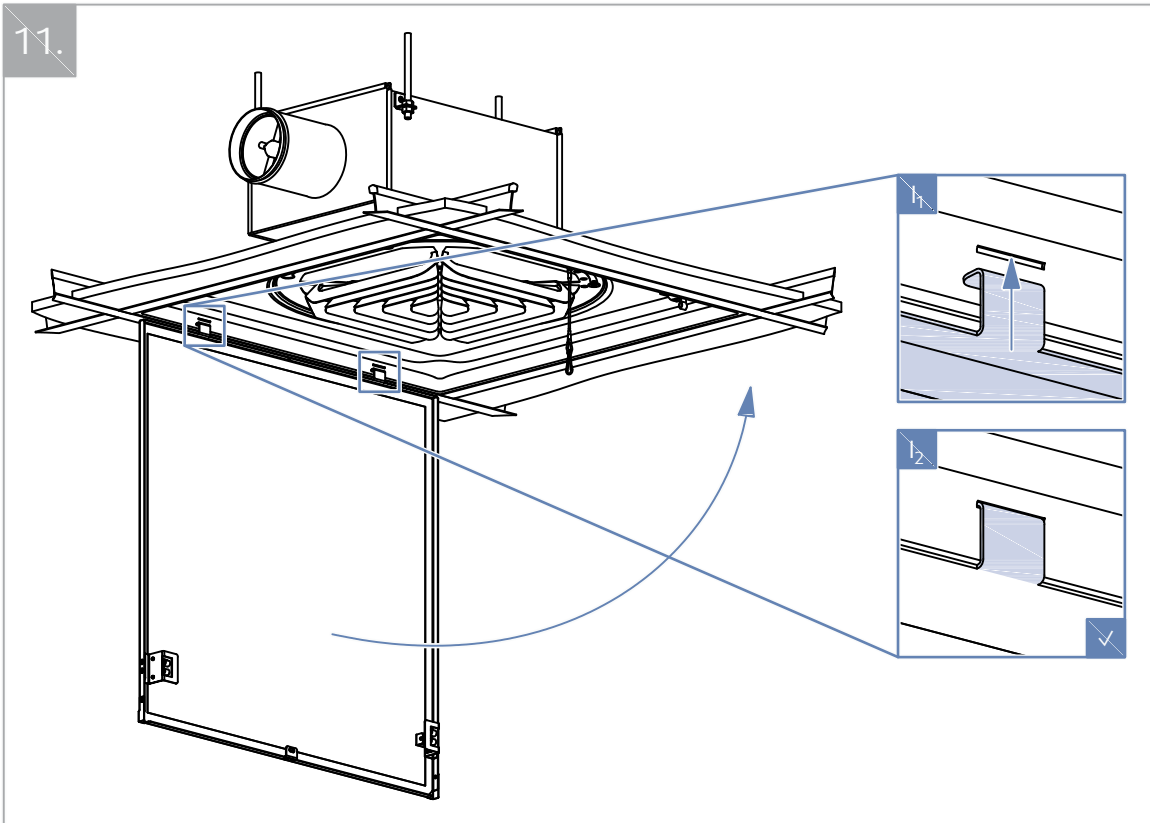

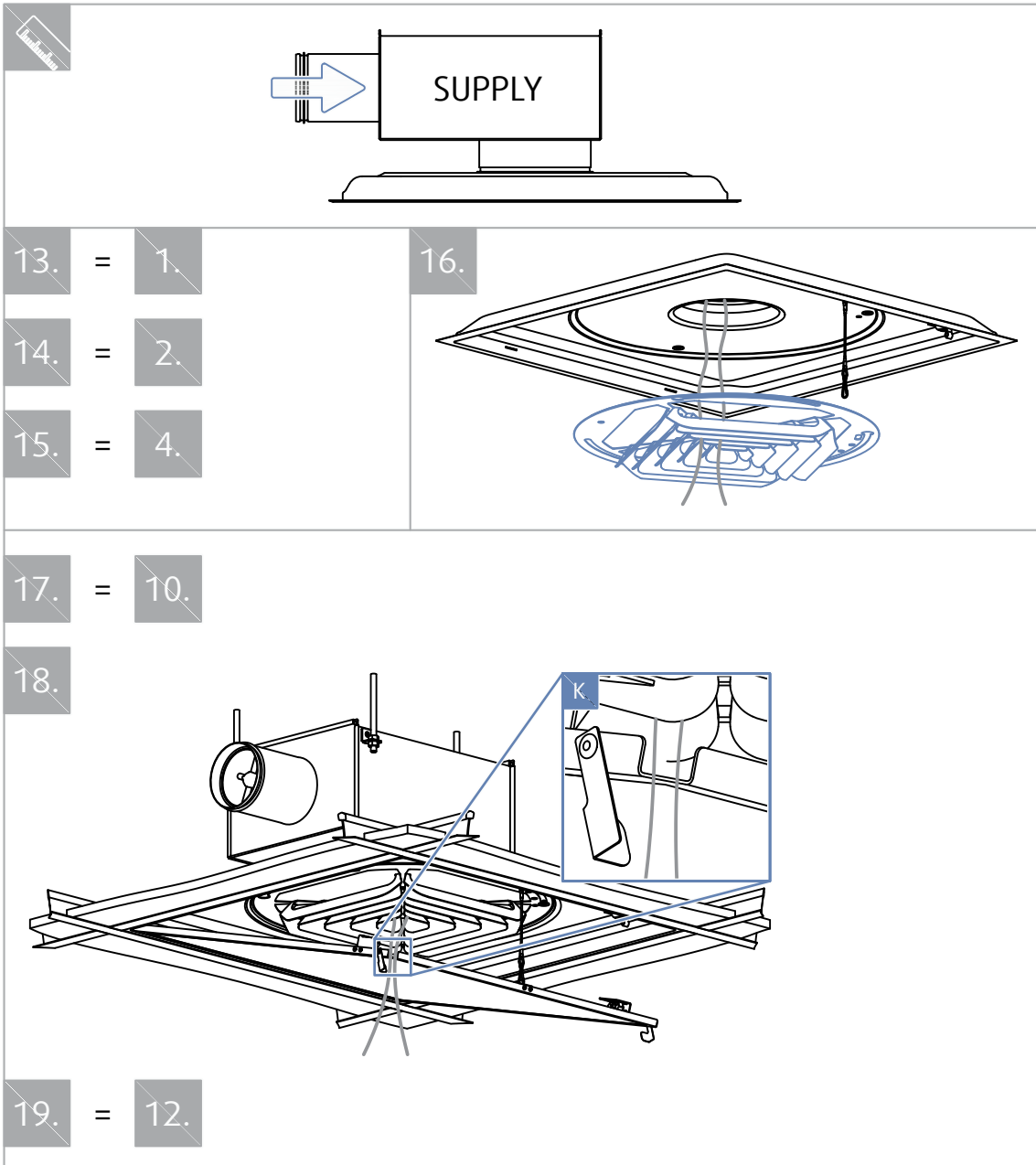



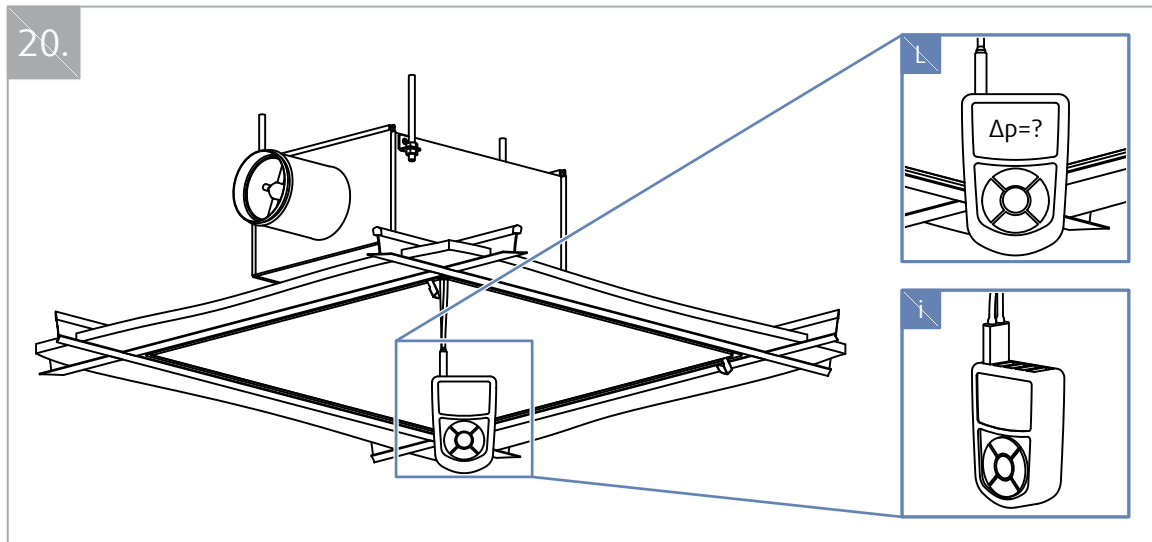







SUPPLY 	k	
TSO-F	m <sup>3</sup> /h	l/s
125	42,12	11,70
160	54,68	15,19
200	100,35	27,88
250	145,59	40,44
315	173,08	48,08

SUPPLY 	k			
TSO-F	THOR	m <sup>3</sup> /h	l/s	
125	100-125	19,08	5,30	
160	125-160	33,12	9,20	
200	160-200	57,24	15,90	
250	200-250	93,60	26,00	
315	250-315	150,12	41,70	

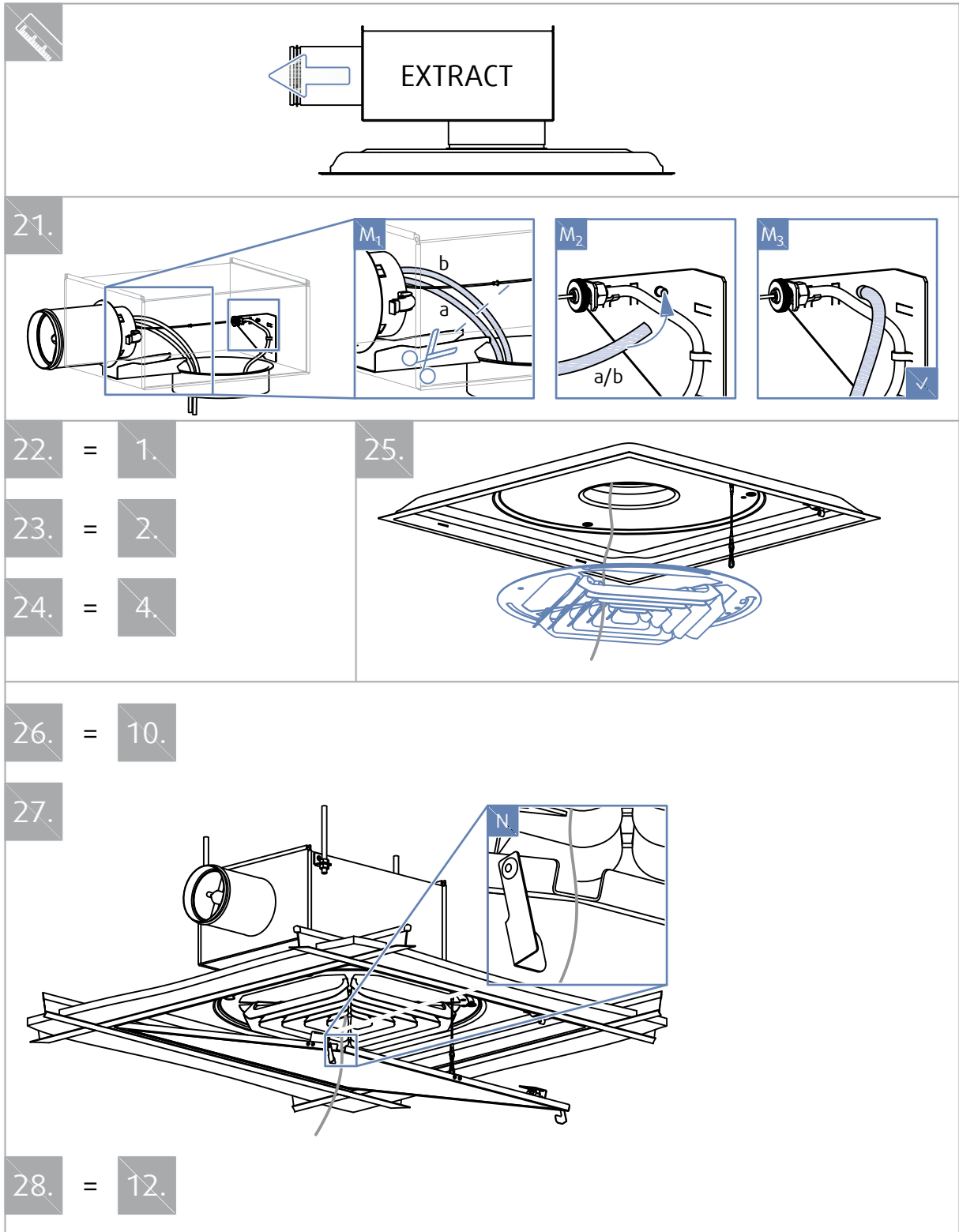
SUPPLY 	k		
TSO-F	THOR-F	m <sup>3</sup> /h	l/s
125	100-125	16,72	4,64
160	100-160	16,72	4,64
200	125-200	28,21	7,84
250	160-250	51,84	14,40
315	250-315	84,57	23,49

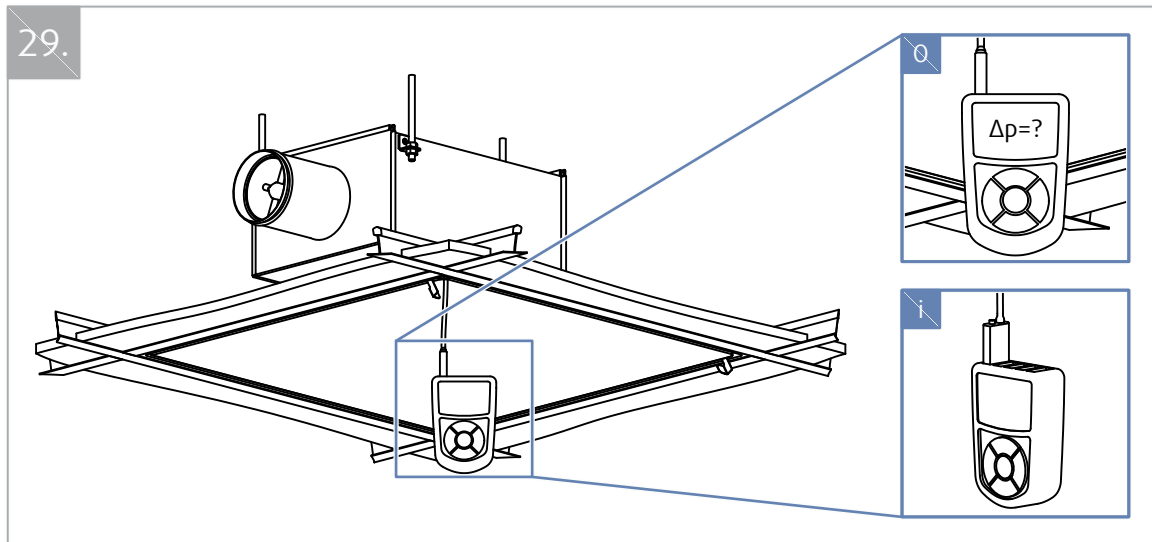



EXTRACT 	k	
TSO-F	m <sup>3</sup> /h	l/s
125	34,23	9,51
160	42,52	11,81
200	71,93	19,98
250	112,52	31,26
315	166,65	46,29

EXTRACT 	k			
TSO-F	THOR	m <sup>3</sup> /h	l/s	
125	100-125	30,20	8,39	
160	125-160	41,81	11,61	
200	160-200	70,13	19,48	
250	200-250	111,06	30,85	
315	250-315	131,10	36,42	

EXTRACT 	k			
TSO-F	THOR-F	m <sup>3</sup> /h	l/s	
125	100-125	25,84	7,18	
160	100-160	37,29	10,36	
200	125-200	70,98	19,72	
250	160-250	99,91	27,75	
315	250-315	149,79	41,61	

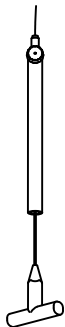
30. = 1.

31. = 2.

32. = 4.

33. 

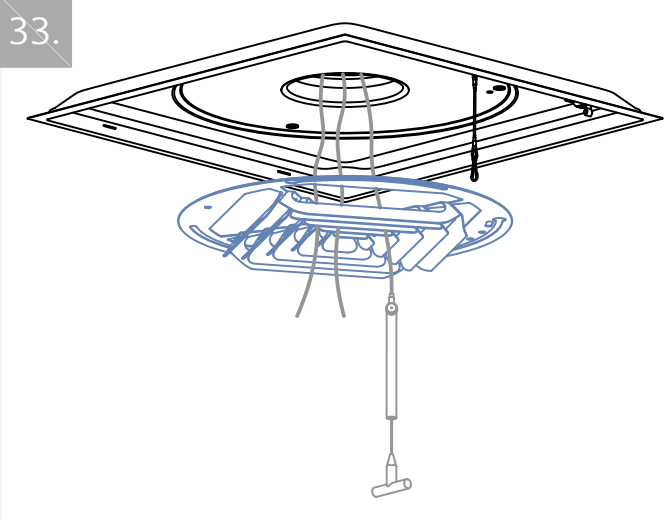
34. = 10.

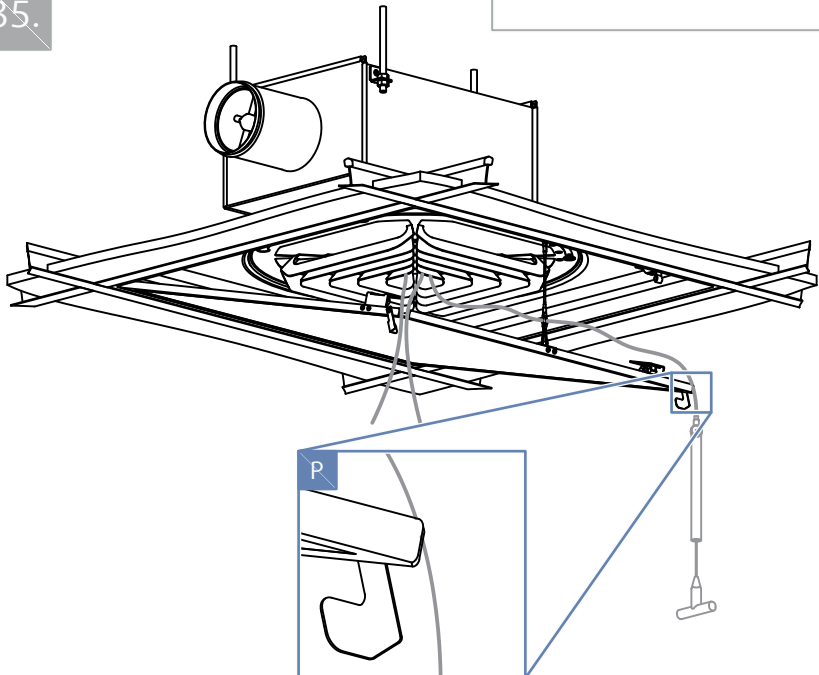
35. 

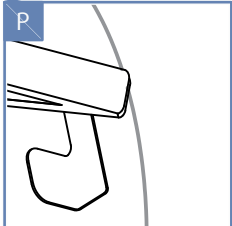

36. = 12.

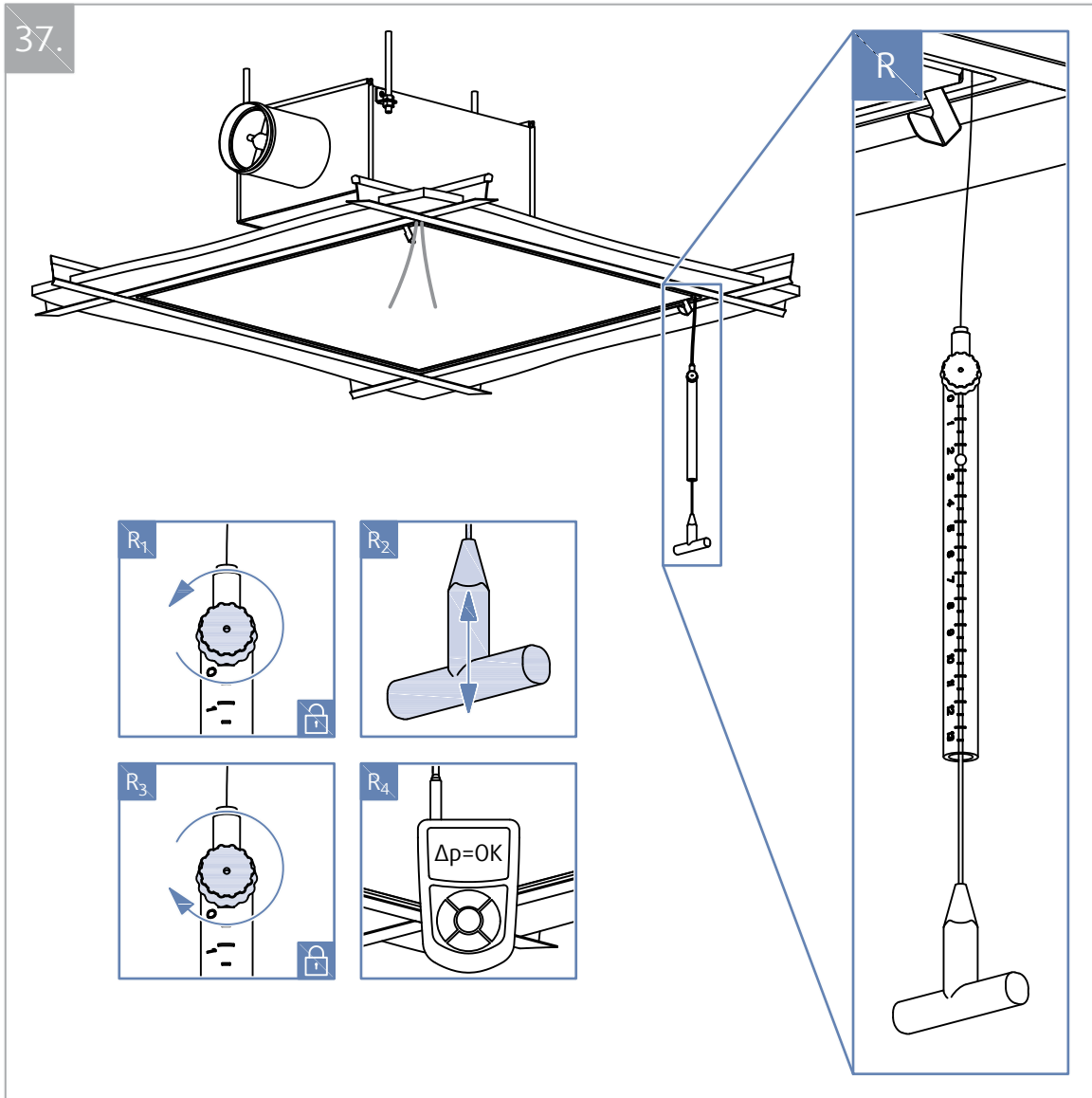

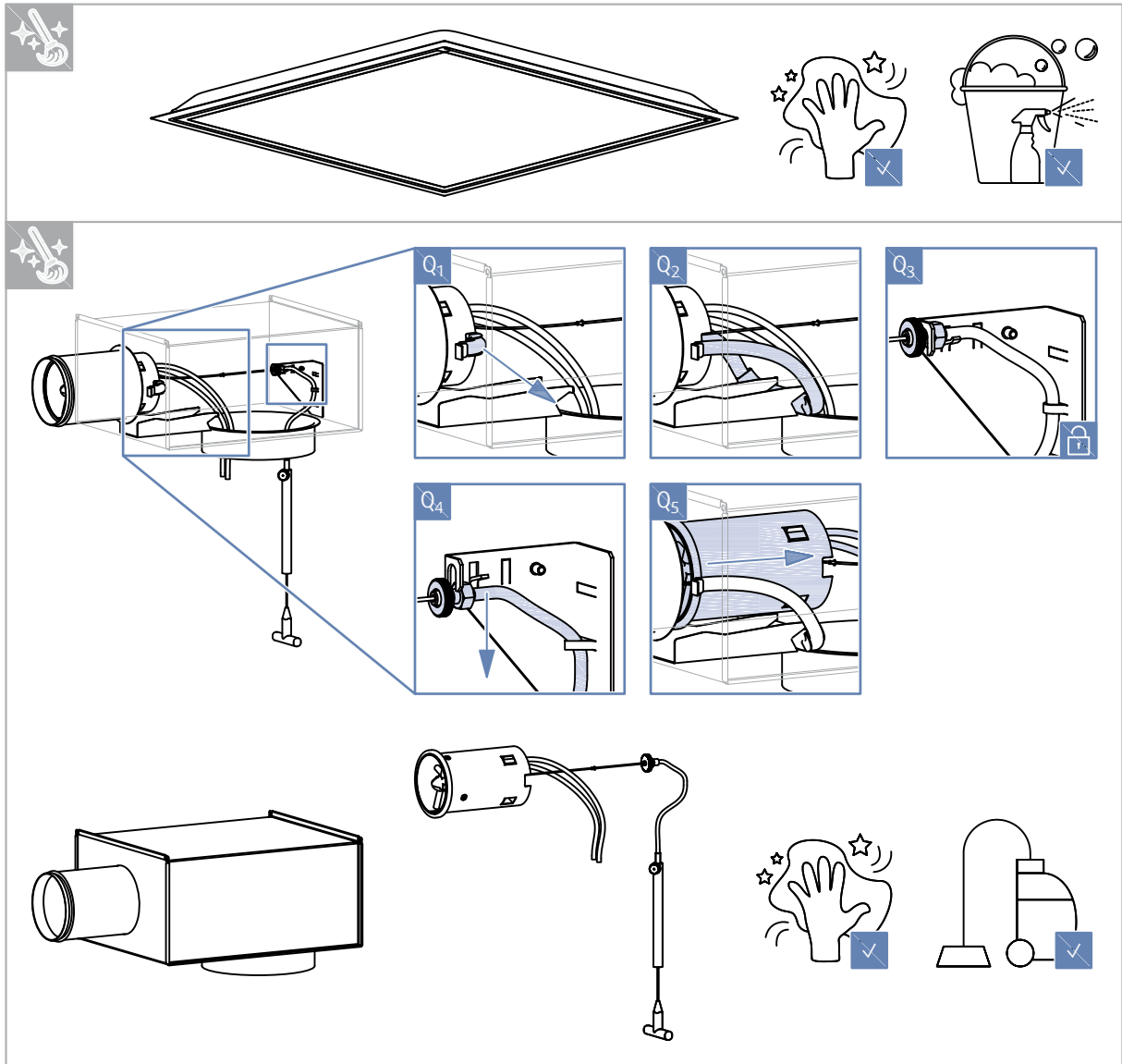

# Transport, Storage and Operation

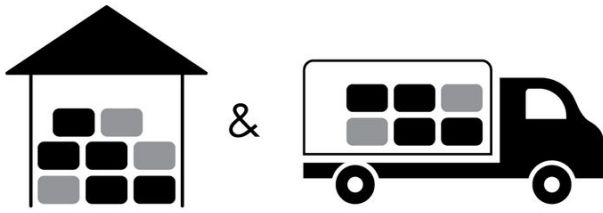

 °C -40°C ... +50°C

 % ≤ 95%



 °C -20°C ... +70°C

 % ≤ 95%

# Supplement

Any deviations from the technical specifications contained herein and the terms should be discussed with the manufacturer. We reserve the right to make any changes to the product without prior notice, provided that these changes do not affect the quality of the product and the required parameters.

Current information on all products is available on [design.systemair.com](http://design.systemair.com).



