

FDS

Rectangular Fire Damper

Handbook

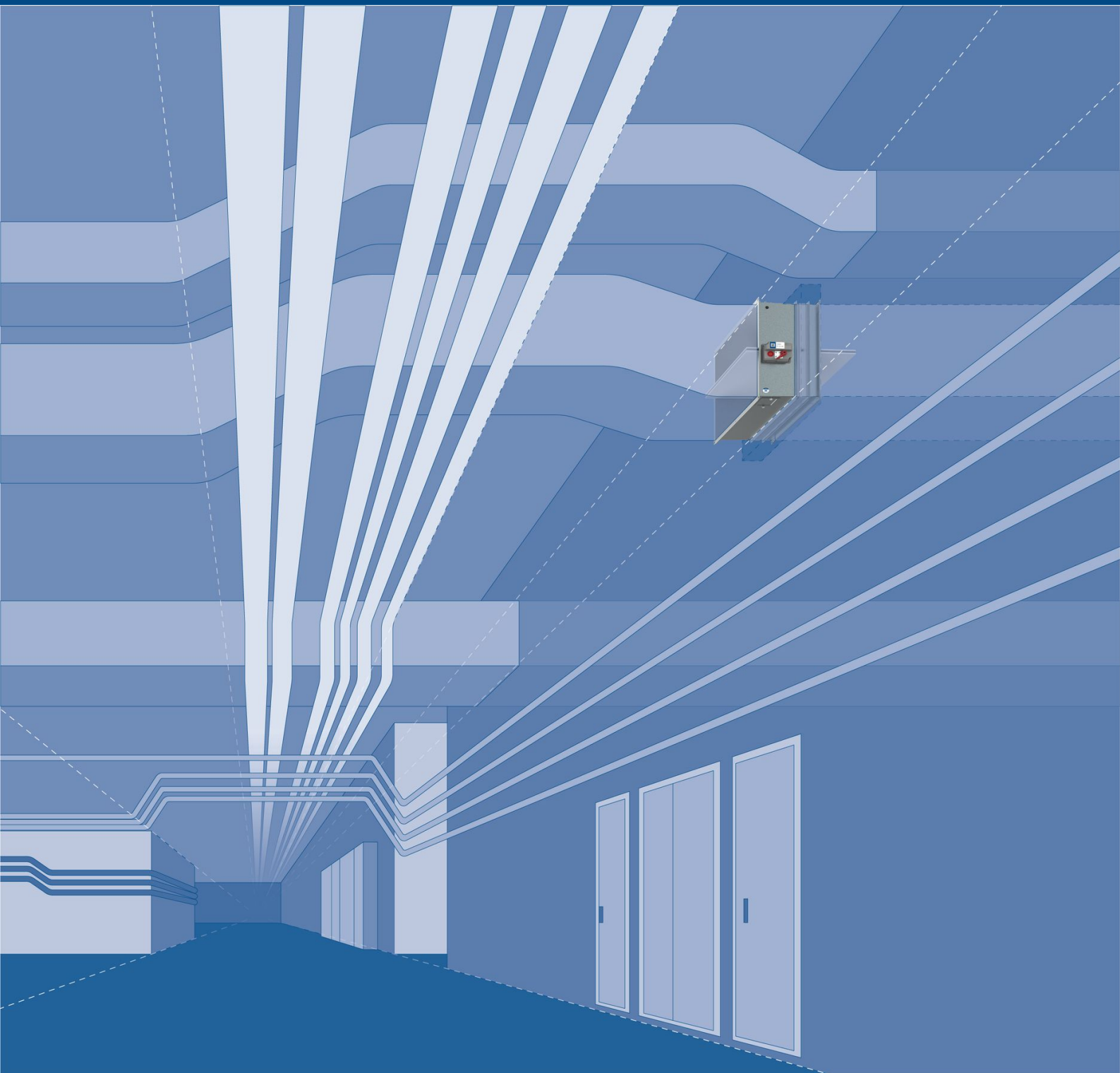
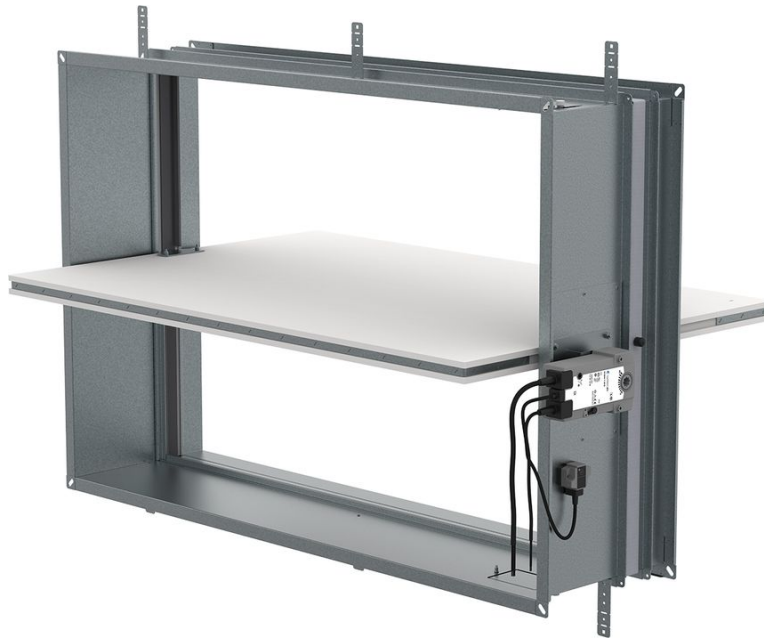

Table of Contents

Overview3
Technical Parameters6
Diagrams12
Dimensions & Weights15
Ordering Code21
Installation23
Electrical Parameters65
Operation Manual91



Description

Fire dampers represent passive fire protection, designed with the help of compartmentalization to prevent the spread of toxic gases, smoke and fire. Standard fire dampers are designed and certified in accordance with EN 15650 and tested for EIS criteria according to EN 1366-2. Fire damper together with its installation form an inseparable part of fire resistivity rating. FDS-3G, FDS-EI90S and FDS-EI120S fire dampers are designed for the installations listed and described in their Handbook. By default, all fire dampers are supplied with a manual mechanism or actuator mechanism, optionally with a supply and communication unit. The activation mechanisms are removable and are interchangeable, for example an actuator operated mechanism instead of a manually operated mechanism.

Highlights

- Lightweight construction
- Casing tightness class C as standard
- Exceptionally low pressure drop
- Changeable mechanism
- Two inspection openings for all sizes greater than 200x200 mm
- Great variety of installations rated up to EI120S
- Multiple FDS-EI90S damper installation - up to 4 dampers with a maximum size of 3260 × 2060 mm
- Modulated actuator suitable for system balancing - possibility to open the blade at the desired angle.

Product Types

- FDS-3G

Rectangular fire damper with a maximum fire resistivity of 120 minutes and a single body design. Size range from 100x100 up to 1200x800 mm.

- FDS-EI90S

Rectangular fire damper with a maximum fire resistivity of 90 minutes. Construction of two sheet metal bodies, conductively connected through a calcium-silicate frame. Width greater than 1200 mm and/or Height greater than 800 mm up to maximum size 1600x1000 mm.

- FDS-EI120S

Rectangular fire damper with a maximum fire resistivity of 120 minutes. Construction of two sheet metal bodies, conductively connected through a calcium-silicate frame. Width greater than 1200 mm and/or Height greater than 800 mm up to maximum size 1600x1000 mm.

Activation Types

Manually Operated Fire Dampers

By default, all manually operated fire dampers are supplied with manual control, optionally with micro switches and electromagnets. In case of fire, the fire damper is closed automatically. Depending on the version, the damper closes either after the melting of the thermal fuse or by means of remote activation through an electromagnet in impulse connection. After the closing of the damper blade, it is mechanically locked in the closed position and can only be opened manually. The actuating mechanism is activated when the temperature of the air in the duct reaches 74°C and the damper closes within 10 seconds after the melting of the fuse.

- **H0**

Fire damper with an activation mechanism with a cover, manual crank and with a spring return release mechanism activated by a fusible thermal link set to 74°C (on-demand 100°C).

- **H2**

Fire damper with an activation mechanism H0 + open and closed indication with 230V AC or 24V AC/DC contact switches.

- **H5-2**

Fire damper with an activation mechanism H0 + a 24V AC/DC electromagnetic release mechanism in the impulse connection (release takes place when the electromagnet is activated) + open and closed indication with 230V AC or 24V AC/DC contact switches.

- **H6-2**

Fire damper with an activation mechanism H0 + a 230V AC electromagnetic release mechanism in the impulse connection (release takes place when the electromagnet is activated) + open and closed indication with 230V AC or 24V AC/DC contact switches.

Actuator- Operated Fire Dampers

By default, all actuator operated fire dampers are supplied with an actuator with micro switches, optionally with a power and communication unit. A fire damper can be equipped with a spring return actuator can be closed with command from the building management system, or after the breaching of the thermoelectric fuse. Actuator operated fire dampers are standardly equipped with a thermoelectric fuse, that activates the closing of the damper after the reaching or exceeding of the ambient temperature of 72°C. The actuator power circuit is interrupted and its spring closes the damper blade within 20 seconds.

Belimo actuator available with on demand fuse 95 °C or 120 °C.

- **B230T or G230T**

Fire damper with an activation mechanism with a Belimo or Gruner spring return actuator (230V AC) with electro-thermal fuse 72°C and auxiliary switches.

- **B24T or G24T**

Fire damper with an activation mechanism with a Belimo or Gruner spring return actuator (24V AC/DC) with electro-thermal fuse 72°C and auxiliary switches.

- **B24T-W or G24T-W**

Fire damper with an activation mechanism with a Belimo or Gruner spring return actuator (24V AC/DC) with an electro-thermal fuse 72°C and auxiliary switches, with provided cable connectors for the supply and communication unit (communication unit not part of the mechanism).

- **B24T-SR or G24T-SR**

Fire damper with an activation mechanism with a Belimo or Gruner spring return actuator (24V AC/DC) with electro-thermal fuse 72°C and auxiliary switches for Modulated dampers (possibility to open the blade at the desired angle). For fire dampers in the size H ≥ 160 mm. Not available for FDS-EI90S/EI120S.

- **BST0 or GST0**

Fire damper with an activation mechanism with a Belimo (BST0) or Gruner (GST0) spring return actuator (AC/DC 24 V) with an electro-thermal fuse 72°C and auxiliary switches, with a Belimo supply unit BKN230-24 (supply through unit: AC 230 V, communication: 2-wire to BKS...) or Gruner supply and communication unit FSC-UFC24-2 (supply through unit: AC 24 V, communication: Modbus/BACnet).

- **BST1**

Fire damper with an activation mechanism with a Belimo spring return actuator (AC/DC 24 V) with an electro-thermal fuse 72°C and auxiliary switches, with a supply and communication unit (SLC powered) BC24-G2 (THC).

- **BST2**

Fire damper with an activation mechanism with a Belimo spring return actuator (AC/DC 24 V) with an electro-thermal fuse 72°C and auxiliary switches, with a Belimo supply and communication unit (AC 230 V) BKN230-24-MOD (Modbus/BACnet).

- **BST3**

Fire damper with an activation mechanism with a Belimo spring return actuator (AC/DC 24 V) with an electro-thermal fuse 72°C and auxiliary switches, with a Belimo supply and communication unit (AC 230 V) BKN230-24-C-MP (SBS/MP).

- **BST10**

Fire damper with an activation mechanism with a Belimo spring return actuator (AC/DC 24 V) with an electro-thermal fuse 72°C and auxiliary switches, with a Belimo supply and communication unit (AC 230 V) BKN230-24-PL (Powerline). Other communication units are possible on demand.

Design

Fire dampers have casings made from galvanized sheet metal. Blades from non-asbestos insulants have a rubber seal for cold smoke and an intumescent seal, that expands in a fire situation.

Material Composition

The product contains galvanized sheet metal, calcium silicate board, fireproof carbon fiberglass, polyurethane foam and ethylene-propylene rubber. These are processed in accordance with local regulations. The product contains no hazardous substances, except for the solder in the thermofuse, which contains a milligram of lead.

List of Accessories

Detailed information about accessories for FDS-3G, FDS-EI90S and FDS-EI120S is available in SystemairDESIGN under Fire Damper Accessories.

- AM-FD: Activation Mechanisms
- CBS-FD: Cover Boards
- IPOS-FD: Insulation Cover Plates
- IKOWS-FD: Installation Kit for Installation on a Wall and out of a Wall Using Promatect Boards

Technical Parameters

Durability test

- 50 cycles/manually operated activation mechanism – with no change of the required properties
- 10000 + 100 + 100 cycles/actuator operated activation mechanism – with no change of the required properties
- 20 000 cycles/modulated actuator (B24T-SR) – with no change of the required properties

Fire testing pressure

Underpressure up to 300 Pa

Safety position

Closed. (In fire scenario the damper closes via spring in actuator or spring in manual mechanism)

Airflow direction

Both directions

Allowed air velocity

Damper can still operate at max. 12 m/s. Air without any mechanical or chemical contamination

Side with fire protection

Depending on installation classification: From both sides (i <-> o)

Repeated opening

Suitable for daily check procedure. It is not possible to operate the device after reaching Activation temperature.

Activation Temperature

- Manually operated: 74 °C as standard (100 °C on request) by means of a spring after the melting of the thermofuse.
- Actuator operated: 72 °C as standard (95 °C or 120 °C on request) by means of the spring after current interruption in the electro-thermal fuse.

Operational temperature

- Minimum: 0 °C
- Maximum: 60 °C for 74 °C and 72 °C thermofuse
- Maximum: 85 °C for 95 °C and 100 °C thermofuse
- Maximum 105 °C for 120 °C thermofuse

Environment suitability

Protected against weather disruptions, with temperature above 0 °C, up to 95% Rha, (3K5 according to EN 60721-3-3)

Open/Closed indication

- Manually operated microswitches - Activation types H2 up to H6-2
- Actuator operated built-in microswitches - Activation types B230T/G230T up to B24T-SR/G24T-SR

Closing/Opening time

Manually operated < 10 s, actuator operated < 20 s

Inspection possibility

By opening of the inspection lid. For smaller sizes than 200 mm after removing of the activation mechanism, or a inspection opening must be added to the connected duct.

Maintenance

Not required. Dry cleaning if demanded by law in the country in which the dampers are installed.

Revisions

Determined by law in the country in which the fire dampers are installed but at least every 12 months.

Allowed pressure

1200 Pa

Blade tightness (STN EN 1751)

Class 3 as standard for all nominal sizes greater than 800x600 mm, For smaller sizes Class 2 as standard and Class 3 on demand.

Tightness of the housing (STN EN 1751)

Class C as standard

Conformity with EC directives

2006/42/EC Machinery Directive

2014/35/EU Low Voltage Directive

2014/30/EU Electromagnetic Compatibility Directive

Modulated Actuator

Can be set to any position when opening the blade - see types of activation mechanisms B24T-SR/G24T-SR

Driving actuator types

Belimo: BLF230-T, BLF24-T, BFL24-SR-T, BF230-T, BF24-T, BF24-SR-T, BFN230-T, BFN24-T, BFN24-T, BFL230-T, BFL24-T, BFL24-SR-T (also with connection possibilities with acronyms ST, W)

Gruner: 360TA-230-12-S2, 360CTA-024-12-S2, 360TA-024-12-S2, 340TA-230D-03-S2, 340TA-024D-03-S2, 340CTA-024D-03-S2, 340TA-230-05-S2, 340TA-024-05-S2, 340CTA-024-05-S2 (also with connection possibilities with acronyms ST, W)

Transport and Storage

Dry indoor conditions with a temperature range of -20 °C to +50 °C

Product parts

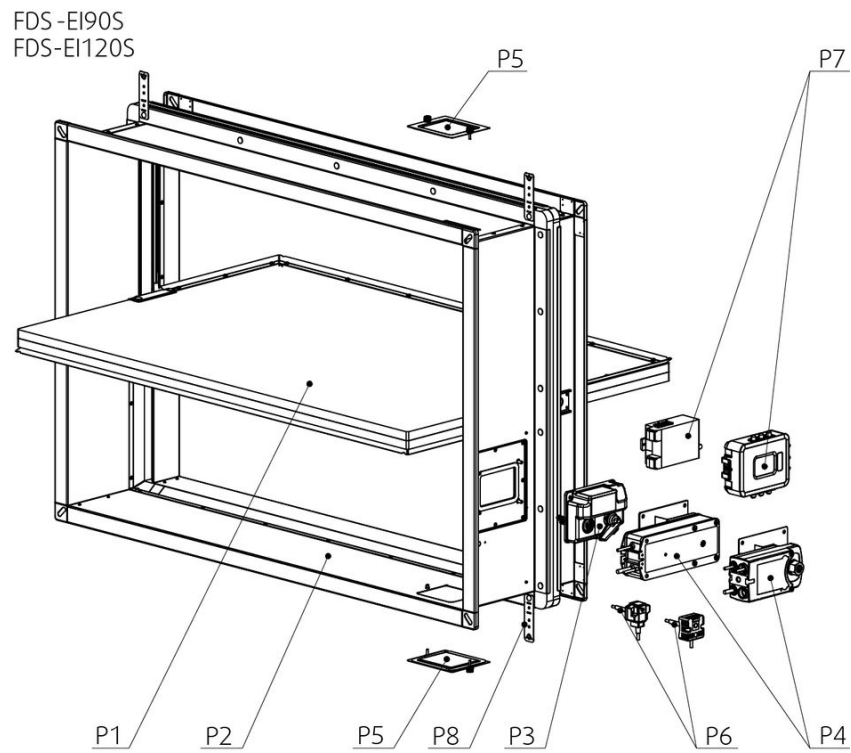
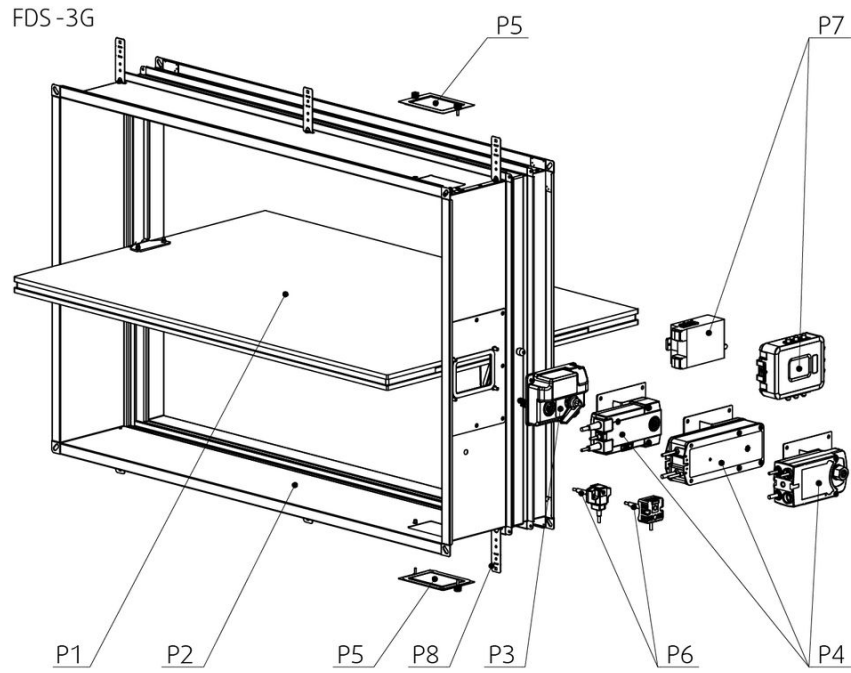

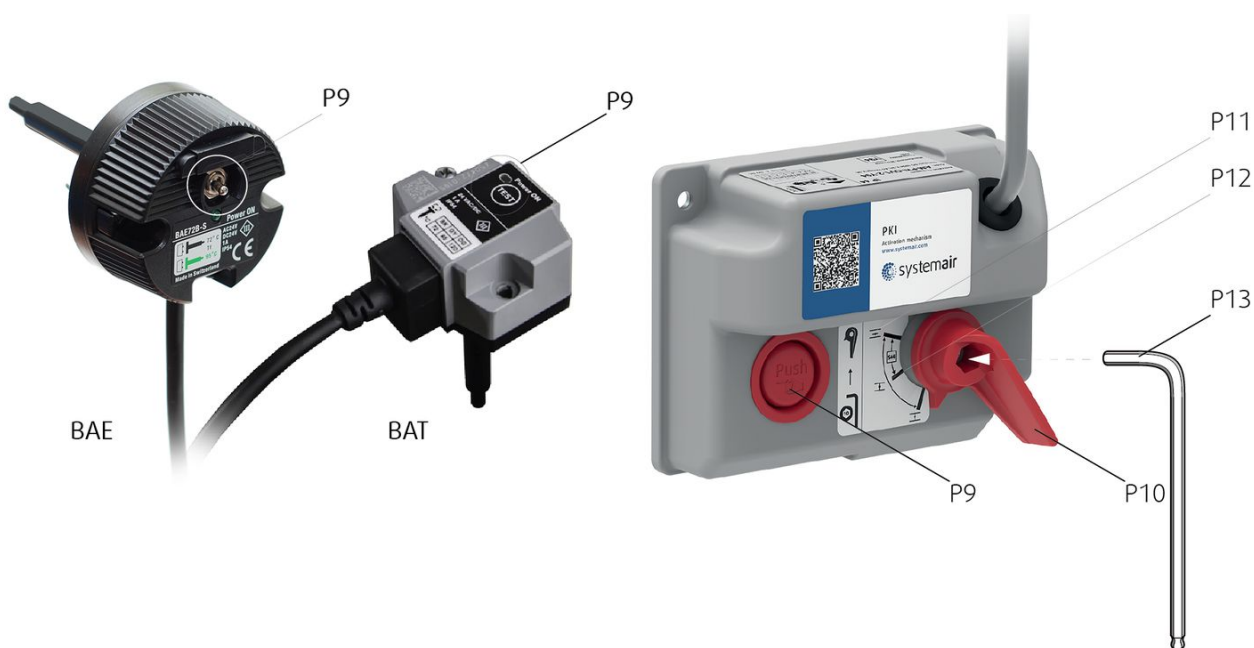

Legend

- P1** Blade
- P2** Casing
- P3** Manually operated activation mechanism (H0;H...)
- P4** Actuator operated activation mechanism (B...;G...)
- P5** Inspection lid
- P6** Thermoelectric fuse (BAT72;TA-72)
- P7** Supply and communication unit (BKN230-24;FS-UFC24-2)
- P8** Bendable hanger
- P9** Release and test button
- P10** Crank
- P11** Open position
- P12** Closed position
- P13** Hexagon bent wrench No.10 (not part of delivery)

Assessed Performance - FDS-3G

19 CE 1396

Systemair Production a.s.

Hlavná 371, 900 43 Kalinkovo, Slovakia

1396-CPR-0163, FDS-3G

(valid for subgroups: ...EX, ...KS, ...OF)

EN 15650 : 2010

Rectangular fire dampers

Nominal activation conditions/sensitivity	Pass
<ul style="list-style-type: none"> sensing element load bearing capacity sensing element response temperature 	
Response delay (response time)	Pass
<ul style="list-style-type: none"> closure time 	
Operational reliability	Pass
<ul style="list-style-type: none"> motorized cycle 10.200 cycles manual cycle 50 cycles modulated 20.200 cycles 	
Fire resistance:	
Resistivity depending on installation method and situation	
<ul style="list-style-type: none"> integrity E maintenance of the cross section (under E) mechanical stability (under E) cross section (under E) insulation I smoke leakage S 	
Durability of response delay	Pass
<ul style="list-style-type: none"> sensing element response temperature and load bearing capacity 	
Durability of operational reliability	Pass
<ul style="list-style-type: none"> open and closing cycle 	

Assessed Performance - FDS-EI90S, FDS-EI120S

19 CE 1396

Systemair Production a.s.

Hlavná 371, 900 43 Kalinkovo, Slovakia

1396-CPR-0169, FDS-EI90S, FDS-EI120S

(valid for subgroups: ...EX)

EN 15650 : 2010

Rectangular fire dampers

Nominal activation conditions/sensitivity		Pass
<ul style="list-style-type: none"> sensing element load bearing capacity sensing element response temperature 		
Response delay (response time)		Pass
<ul style="list-style-type: none"> closure time 		
Operational reliability		Pass
<ul style="list-style-type: none"> motorized cycle manual cycle modulated 	<ul style="list-style-type: none"> 10.200 cycles 50 cycles 20.200 cycles 	
Fire resistance:		
FDS-EI90S	EI90(ve ho i↔o)S	
FDS-EI120S	EI120(ve ho i↔o)S	
<ul style="list-style-type: none"> integrity E maintenance of the cross section (under E) mechanical stability (under E) cross section (under E) insulation I smoke leakage S 		
Durability of response delay		Pass
<ul style="list-style-type: none"> sensing element response temperature and load bearing capacity 		
Durability of operational reliability		Pass
<ul style="list-style-type: none"> open and closing cycle 		

Diagrams

The pressure drop and A-weighted total discharged sound power level depend on the nominal width and height of the damper and air flow volume at different duct pressures. The type of activation does not influence the airflow parameter, therefore only one activation type is shown in the diagrams.

FDS-3G-...

Pressure drop & A-weighted sound power level in dB(A)

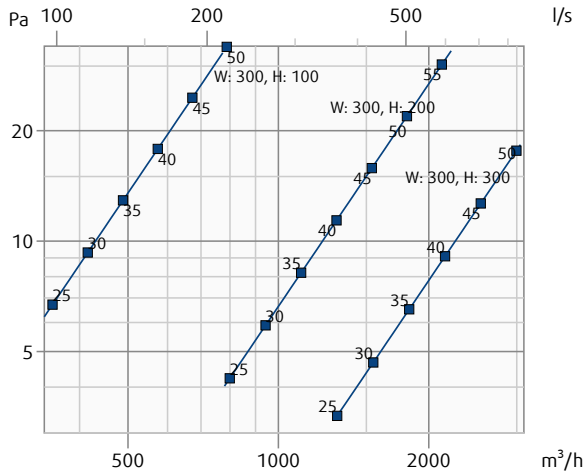

FDS-3G-...

Pressure drop & A-weighted sound power level in dB(A)

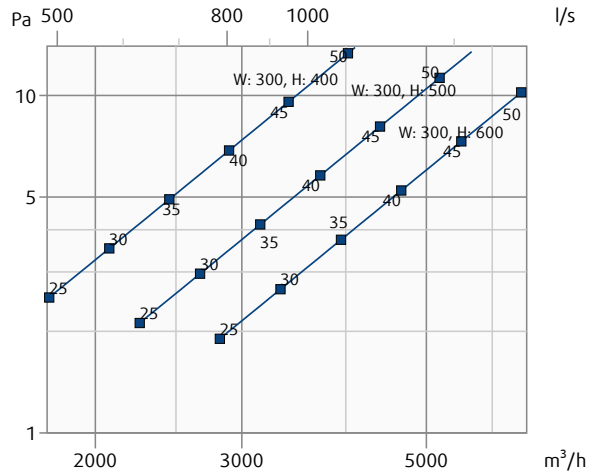

FDS-3G-...

Pressure drop & A-weighted sound power level in dB(A)

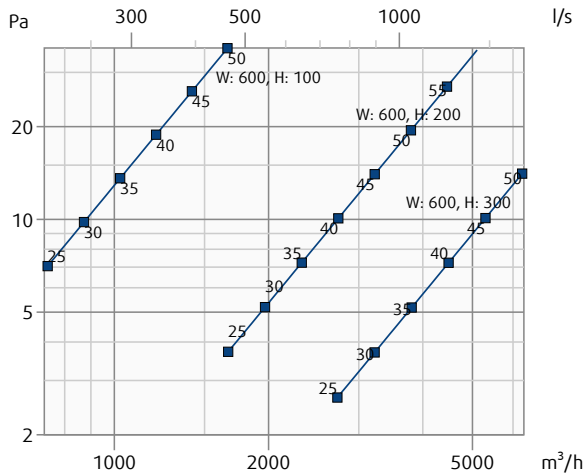

FDS-3G-...

Pressure drop & A-weighted sound power level in dB(A)

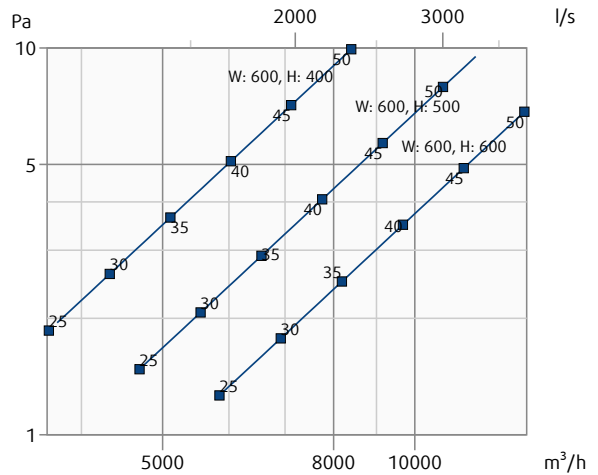

FDS-3G-...

Pressure drop & A-weighted sound power level in dB(A)

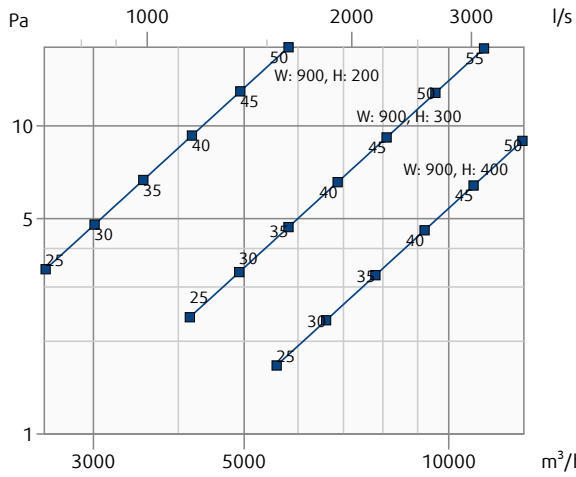

FDS-3G-...

Pressure drop & A-weighted sound power level in dB(A)

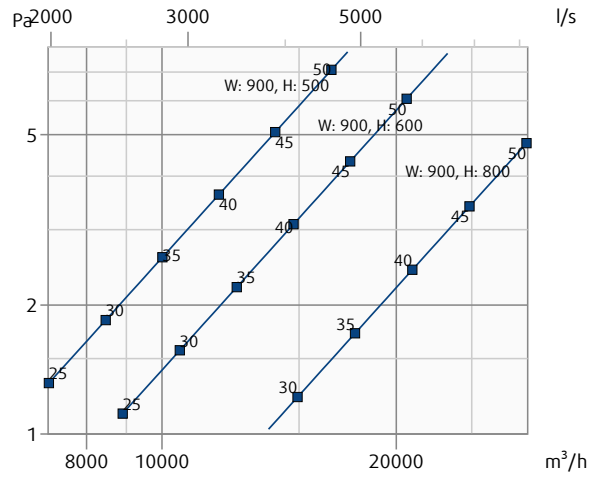

FDS-3G-...

Pressure drop & A-weighted sound power level in dB(A)

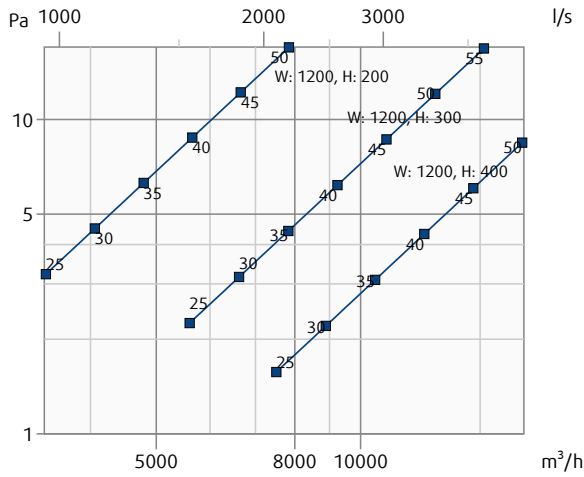

FDS-3G-...

Pressure drop & A-weighted sound power level in dB(A)

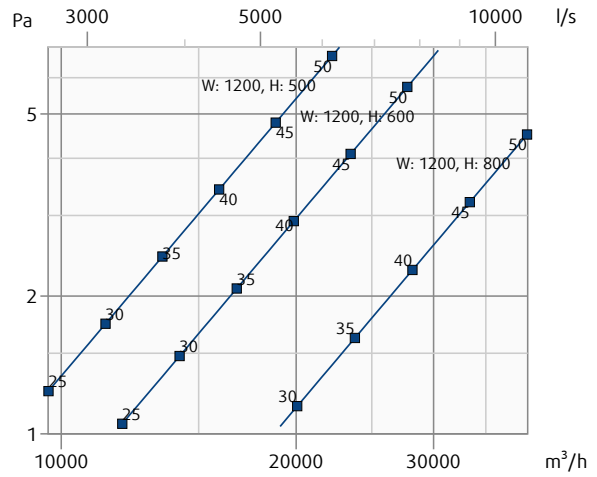

FDS-EI90S-...

Pressure drop & A-weighted sound power level in dB(A)

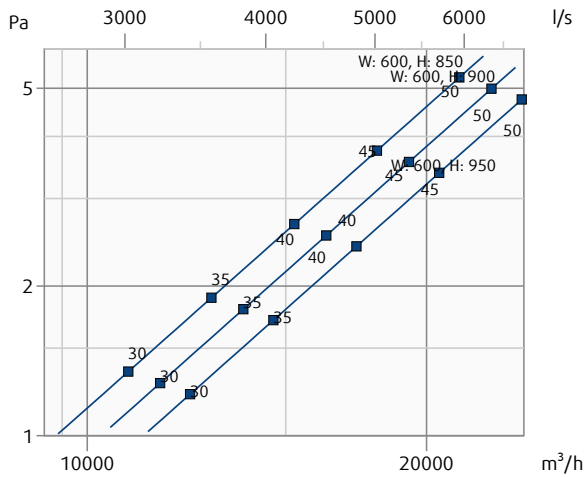

FDS-EI90S-...

Pressure drop & A-weighted sound power level in dB(A)

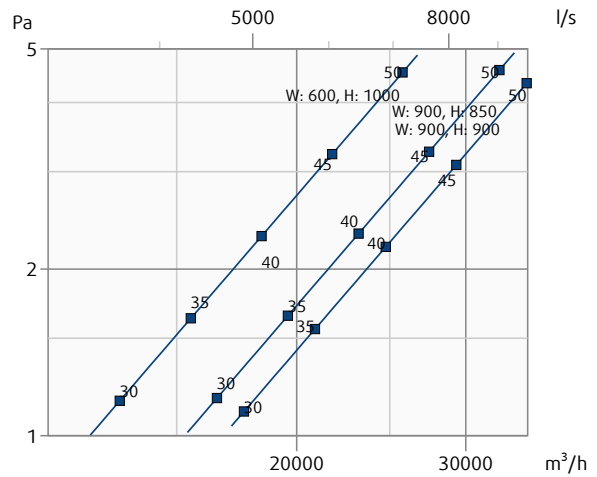

FDS-EI90S-...

Pressure drop & A-weighted sound power level in dB(A)

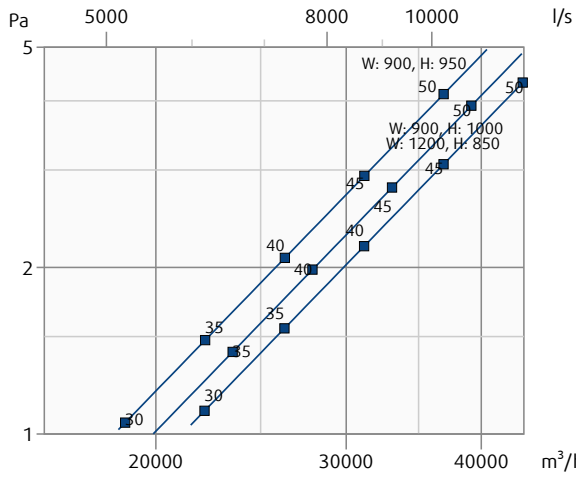

FDS-EI90S-...

Pressure drop & A-weighted sound power level in dB(A)

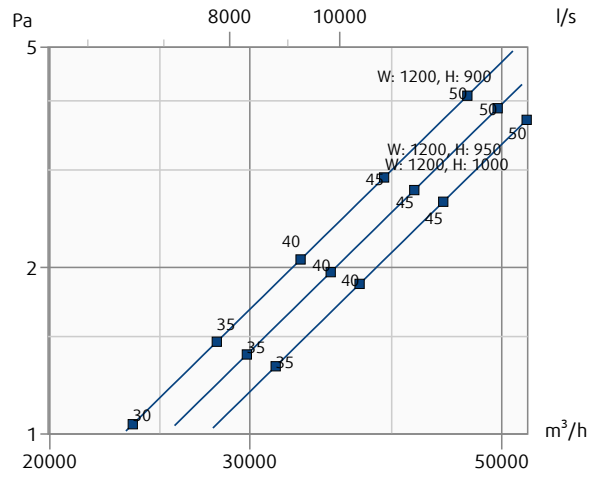

FDS-EI90S-...

Pressure drop & A-weighted sound power level in dB(A)

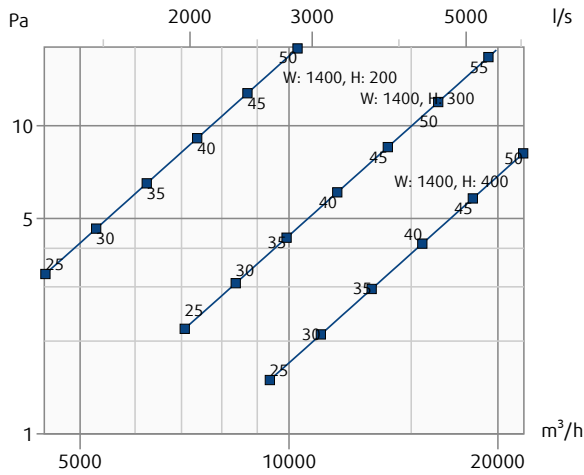

FDS-EI90S-...

Pressure drop & A-weighted sound power level in dB(A)

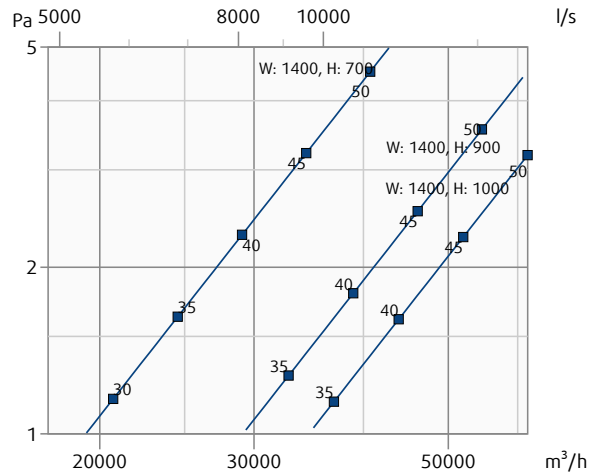

FDS-EI90S-...

Pressure drop & A-weighted sound power level in dB(A)

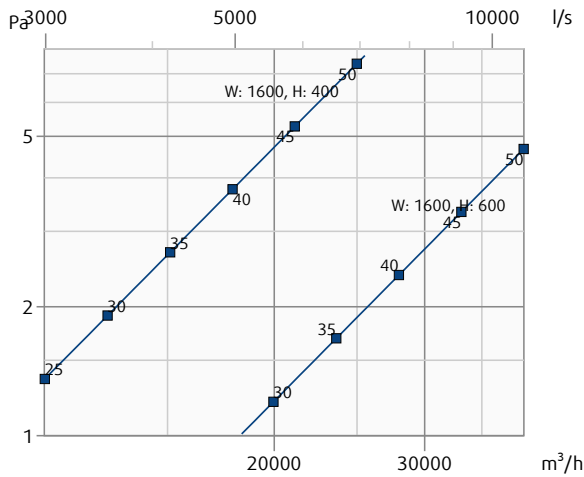

FDS-EI90S-...

Pressure drop & A-weighted sound power level in dB(A)

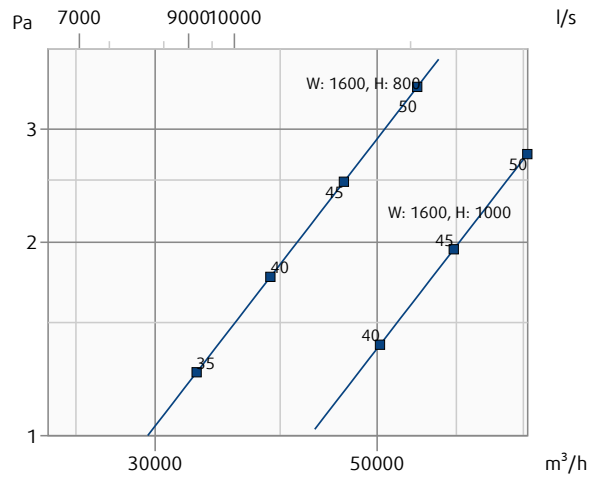



Free area

A _v (m ²)	W (mm)																				
	100	150	200	250	300	315	350	355	400	450	500	550	560	600	630	650	700	710	750	800	
H (mm)	100	0,007	0,010	0,014	0,018	0,022	0,023	0,026	0,026	0,030	0,030	0,034	0,037	0,038	0,041	0,043	0,044	0,048	0,049	0,051	0,055
	150	0,011	0,015	0,021	0,027	0,033	0,034	0,038	0,039	0,044	0,047	0,052	0,058	0,059	0,063	0,066	0,068	0,074	0,075	0,079	0,085
	175	0,013	0,019	0,026	0,033	0,040	0,042	0,047	0,048	0,054	0,058	0,064	0,071	0,072	0,078	0,082	0,084	0,091	0,092	0,098	0,104
	180	0,014	0,019	0,027	0,034	0,041	0,043	0,048	0,049	0,056	0,060	0,067	0,074	0,075	0,081	0,085	0,087	0,094	0,096	0,101	0,108
	200	0,016	0,022	0,030	0,039	0,047	0,049	0,055	0,056	0,063	0,067	0,074	0,082	0,084	0,090	0,095	0,098	0,105	0,107	0,113	0,121
	250	-	0,029	0,040	0,050	0,061	0,064	0,072	0,073	0,083	0,088	0,099	0,109	0,111	0,119	0,125	0,129	0,140	0,142	0,150	0,160
	300	-	0,036	0,049	0,062	0,075	0,079	0,089	0,090	0,102	0,110	0,123	0,135	0,138	0,148	0,156	0,161	0,174	0,176	0,186	0,199
	315	-	-	0,052	0,066	0,080	0,084	0,094	0,095	0,108	0,116	0,130	0,143	0,146	0,157	0,165	0,170	0,184	0,187	0,197	0,211
	350	-	-	0,058	0,074	0,090	0,094	0,105	0,107	0,121	0,132	0,147	0,162	0,165	0,177	0,186	0,193	0,208	0,211	0,223	0,238
	355	-	-	0,059	0,075	0,091	0,096	0,107	0,109	0,123	0,134	0,149	0,165	0,168	0,180	0,190	0,196	0,211	0,214	0,227	0,242
	400	-	-	-	0,086	0,104	0,109	0,122	0,124	0,140	0,153	0,171	0,189	0,192	0,206	0,217	0,224	0,242	0,245	0,260	0,277
	450	-	-	-	0,094	0,114	0,120	0,134	0,136	0,154	0,175	0,195	0,215	0,219	0,235	0,248	0,256	0,276	0,280	0,296	0,316
	500	-	-	-	0,105	0,128	0,135	0,151	0,153	0,174	0,196	0,219	0,242	0,246	0,265	0,278	0,287	0,310	0,315	0,333	0,356
	550	-	-	-	-	0,142	0,15	0,167	0,170	0,193	0,218	0,243	0,268	0,273	0,294	0,309	0,319	0,344	0,349	0,369	0,395
	560	-	-	-	-	0,145	0,153	0,171	0,173	0,197	0,222	0,248	0,274	0,279	0,300	0,315	0,325	0,351	0,356	0,377	0,403
	600	-	-	-	-	0,156	0,165	0,184	0,187	0,212	0,240	0,267	0,295	0,301	0,323	0,339	0,351	0,378	0,384	0,406	0,434
	630	-	-	-	-	-	0,151	0,171	0,174	0,199	0,227	0,255	0,283	0,288	0,311	0,328	0,339	0,367	0,372	0,395	0,423
	650	-	-	-	-	-	-	0,177	0,180	0,206	0,235	0,264	0,293	0,299	0,322	0,339	0,351	0,380	0,386	0,409	0,438
	700	-	-	-	-	-	-	0,192	0,195	0,224	0,255	0,287	0,318	0,324	0,350	0,369	0,381	0,413	0,419	0,444	0,476
	710	-	-	-	-	-	-	-	-	0,227	0,259	0,291	0,323	0,330	0,355	0,374	0,387	0,419	0,426	0,451	0,483
750	-	-	-	-	-	-	-	-	0,241	0,275	0,309	0,343	0,350	0,377	0,398	0,411	0,445	0,452	0,479	0,513	
800	-	-	-	-	-	-	-	-	-	0,296	0,332	0,369	0,376	0,405	0,427	0,442	0,478	0,485	0,515	0,551	
850	-	-	-	-	-	-	-	-	-	0,358	0,399	0,439	0,447	0,479	0,503	0,520	0,560	0,568	0,600	0,640	
	-	-	-	-	-	-	-	-	-	0,349	0,389	0,429	0,437	0,469	0,493	0,509	0,549	0,557	0,589	0,628	
900	-	-	-	-	-	-	-	-	-	0,381	0,423	0,466	0,475	0,509	0,535	0,552	0,595	0,603	0,637	0,680	
	-	-	-	-	-	-	-	-	-	0,371	0,413	0,456	0,464	0,498	0,524	0,541	0,583	0,592	0,625	0,668	
950	-	-	-	-	-	-	-	-	-	-	0,448	0,494	0,503	0,539	0,566	0,584	0,629	0,638	0,675	0,720	
	-	-	-	-	-	-	-	-	-	-	0,438	0,483	0,492	0,528	0,555	0,573	0,617	0,626	0,662	0,707	
1000	-	-	-	-	-	-	-	-	-	-	0,473	0,521	0,530	0,569	0,597	0,616	0,664	0,674	0,712	0,760	
	-	-	-	-	-	-	-	-	-	-	0,462	0,510	0,519	0,557	0,585	0,604	0,652	0,661	0,699	0,747	

FDS-3G (L = 325 mm)
FDS-EI90S (L = 350 mm)
FDS-EI120S (L = 350 mm)

A _v (m ²)		W (mm)																
		850	900	950	1000	1050	1100	1120	1150	1200	1250	1300	1350	1400	1450	1500	1550	1600
H (mm)	100	-	-	-	-	-	-	-	-	-	-	-	-	-	-	-	-	-
	150	-	-	-	-	-	-	-	-	-	-	-	-	-	-	-	-	-
	175	-	-	-	-	-	-	-	-	-	-	-	-	-	-	-	-	-
	180	-	-	-	-	-	-	-	-	-	-	-	-	-	-	-	-	-
	200	0,105	0,111	0,118	0,124	0,131	0,137	0,140	0,144	0,150	0,193	0,201	0,209	0,217	0,224	0,232	-	-
											0,183	0,19	0,198	0,205	0,212	0,22	-	-
	250	0,145	0,154	0,163	0,172	0,181	0,190	0,194	0,199	0,208	0,256	0,266	0,276	0,286	0,297	0,307	-	-
											0,245	0,255	0,265	0,274	0,284	0,294	-	-
	300	0,185	0,197	0,208	0,220	0,231	0,243	0,247	0,254	0,266	0,318	0,331	0,343	0,356	0,369	0,382	-	-
											0,307	0,319	0,331	0,344	0,356	0,369	-	-
	315	0,197	0,209	0,222	0,234	0,246	0,258	0,263	0,271	0,283	0,337	0,35	0,364	0,377	0,391	0,404	-	-
											0,325	0,338	0,352	0,365	0,378	0,391	-	-
	350	0,225	0,239	0,253	0,267	0,281	0,295	0,301	0,309	0,323	0,38	0,395	0,411	0,426	0,441	0,457	-	-
											0,369	0,383	0,398	0,413	0,428	0,443	-	-
	355	0,229	0,244	0,258	0,272	0,286	0,301	0,306	0,315	0,329	0,386	0,402	0,417	0,433	0,449	0,464	-	-
											0,375	0,39	0,405	0,42	0,436	0,451	-	-
	400	0,266	0,282	0,299	0,315	0,332	0,348	0,355	0,365	0,381	0,442	0,46	0,478	0,496	0,514	0,531	0,549	0,567
											0,43	0,448	0,465	0,483	0,5	0,518	0,535	0,553
	450	0,306	0,325	0,344	0,363	0,382	0,401	0,409	0,420	0,439	0,505	0,525	0,545	0,566	0,586	0,606	0,627	0,647
											0,492	0,512	0,532	0,552	0,572	0,592	0,612	0,632
	500	0,346	0,368	0,389	0,411	0,432	0,454	0,462	0,475	0,497	0,567	0,59	0,613	0,635	0,658	0,681	0,704	0,727
											0,554	0,577	0,599	0,622	0,644	0,667	0,689	0,712
	550	0,386	0,410	0,434	0,458	0,482	0,506	0,516	0,530	0,554	0,629	0,655	0,68	0,705	0,731	0,756	0,781	0,806
											0,616	0,641	0,666	0,691	0,716	0,741	0,766	0,791
	560	0,394	0,419	0,443	0,468	0,492	0,517	0,527	0,541	0,566	0,642	0,668	0,693	0,719	0,745	0,771	0,797	0,822
											0,629	0,654	0,68	0,705	0,731	0,756	0,781	0,807
	600	0,427	0,453	0,480	0,506	0,533	0,559	0,570	0,586	0,612	0,692	0,719	0,747	0,775	0,803	0,831	0,858	0,886
											0,678	0,706	0,733	0,761	0,788	0,816	0,843	0,87
	630	0,451	0,479	0,507	0,535	0,563	0,591	0,602	0,619	0,647	0,729	0,758	0,788	0,817	0,846	0,875	0,905	0,934
											0,715	0,744	0,773	0,802	0,831	0,86	0,889	0,918
650	0,467	0,496	0,525	0,554	0,583	0,612	0,624	0,641	0,670	0,754	0,784	0,815	0,845	0,875	0,905	0,936	0,966	
										0,74	0,77	0,8	0,83	0,86	0,89	0,92	0,95	
700	0,507	0,539	0,570	0,602	0,633	0,665	0,677	0,696	0,728	0,816	0,849	0,882	0,915	0,947	0,98	1,013	1,046	
										0,802	0,835	0,867	0,9	0,932	0,964	0,997	1,029	
710	0,515	0,547	0,579	0,611	0,643	0,675	0,688	0,707	0,739	0,829	0,862	0,895	0,929	0,962	0,995	1,028	1,062	
										0,815	0,848	0,88	0,913	0,946	0,979	1,012	1,045	
750	0,547	0,581	0,615	0,649	0,683	0,717	0,731	0,751	0,785	0,879	0,914	0,949	0,984	1,02	1,055	1,09	1,126	
										0,864	0,899	0,934	0,969	1,004	1,039	1,074	1,109	
800	0,588	0,624	0,661	0,697	0,734	0,770	0,785	0,807	0,843	0,941	0,979	1,016	1,054	1,092	1,13	1,168	1,205	
										0,926	0,964	1,001	1,038	1,076	1,113	1,151	1,188	
850	0,681	0,721	0,761	0,802	0,842	0,882	0,898	0,923	0,963	1,003	1,043	1,084	1,124	1,164	1,205	1,245	1,285	
										0,668	0,708	0,748	0,788	0,828	0,868	0,884	0,908	0,948
900	0,723	0,766	0,809	0,851	0,894	0,937	0,954	0,98	1,023	1,065	1,108	1,151	1,194	1,237	1,279	1,322	1,365	
										0,71	0,753	0,795	0,838	0,88	0,923	0,94	0,965	1,008
950	0,765	0,811	0,856	0,901	0,947	0,992	1,01	1,037	1,082	1,128	1,173	1,218	1,264	1,309	1,354	1,4	1,445	
										0,752	0,797	0,842	0,887	0,932	0,977	0,995	1,022	1,067
1000	0,808	0,855	0,903	0,951	0,999	1,047	1,066	1,094	1,142	1,19	1,238	1,286	1,333	1,381	1,429	1,477	1,525	
										0,794	0,842	0,889	0,937	0,984	1,032	1,051	1,079	1,126

 FDS-3G (L = 325 mm)
 FDS-EI90S (L = 350 mm)
 FDS-EI120S (L = 350 mm)

Dimensions & Weights

Dimensions

To avoid blocking the movement of a damper blade, connect a straight duct at minimal lengths respectively R1 or R2. R1 and R2 are the overhang of the fully open blade, including seals and gaskets on the damper blade.

NOTES

* For nominal size W = 100 mm the internal width dimension is 100 mm, flange outside width dimension 152 mm and/or for nominal size H = 100 mm the internal height dimension is 100 mm, flange outside height dimension 152 mm.

FDS-3G, 100 x 100 up to 1200 x 800

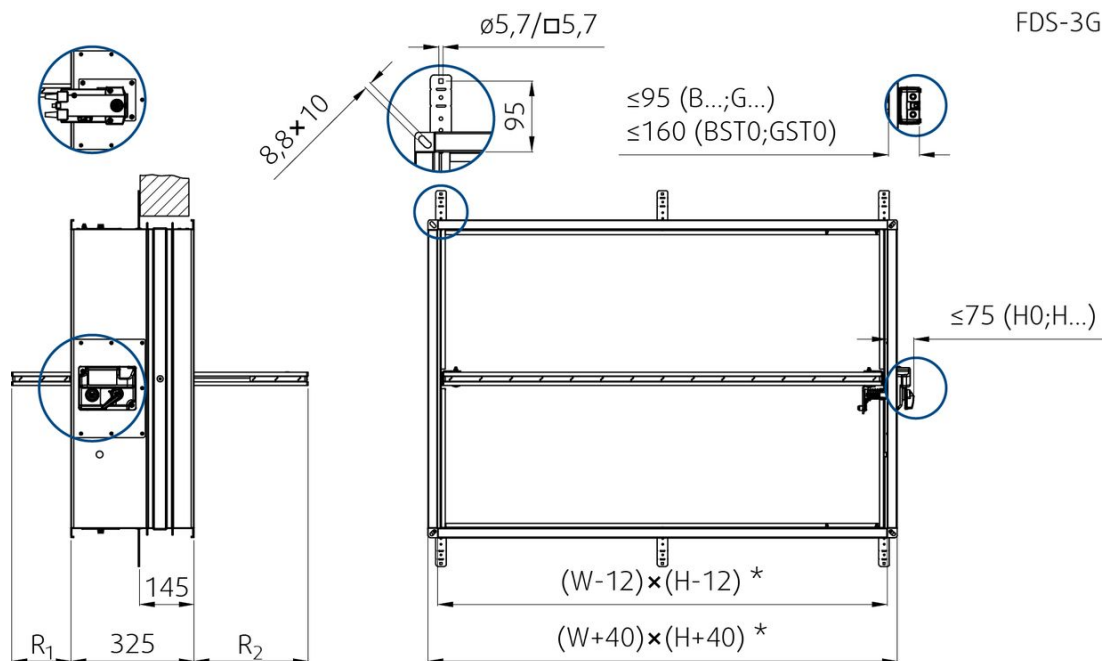

Weights

H0, H... m (kg ±10%)		W (mm)																			
		100	150	200	250	300	315	350	355	400	450	500	550	560	600	630	650	700	710	750	800
H (mm)	100	4,2	4,6	5,1	5,5	6,0	6,1	6,4	6,5	6,9	7,4	7,8	8,3	8,4	8,8	9,0	9,2	9,7	9,8	10,1	10,6
	150	4,6	5,1	5,6	6,2	6,7	6,8	7,2	7,3	7,7	8,3	8,8	9,3	9,4	9,9	10,2	10,4	10,9	11,0	11,4	11,9
	200	5,1	5,7	6,2	6,8	7,4	7,6	8,0	8,1	8,6	9,2	9,8	10,4	10,5	11,0	11,3	11,6	12,2	12,3	12,7	13,3
	250	-	6,2	6,8	7,5	8,1	8,3	8,8	8,9	9,4	10,2	10,8	11,5	11,6	12,1	12,5	12,8	13,4	13,5	14,1	14,7
	300	-	6,7	7,4	8,1	8,8	9,1	9,6	9,7	10,3	11,1	11,8	12,5	12,6	13,2	13,6	13,9	14,6	14,8	15,4	16,1
	315	-	-	7,6	8,3	9,1	9,3	9,8	9,9	10,5	11,3	12,1	12,8	13,0	13,5	14,0	14,3	15,0	15,2	15,8	16,5
	350	-	-	8,0	8,8	9,6	9,8	10,3	10,4	11,1	12,0	12,8	13,5	13,7	14,3	14,8	15,1	15,9	16,0	16,7	17,5
	355	-	-	8,1	8,9	9,7	9,9	10,4	10,5	11,2	12,1	12,9	13,6	13,8	14,4	14,9	15,2	16,0	16,2	16,8	17,6
	400	-	-	8,6	9,4	10,3	10,5	11,1	11,2	12,0	12,9	13,7	14,6	14,8	15,4	15,9	16,3	17,1	17,3	18,0	18,8
	450	-	-	-	10,1	11,0	11,3	11,9	12,0	12,8	13,8	14,7	15,6	15,8	16,5	17,1	17,5	18,4	18,6	19,3	20,2
	500	-	-	-	10,7	11,7	12,0	12,7	12,8	13,7	14,7	15,7	16,7	16,9	17,7	18,2	18,6	19,6	19,8	20,6	21,6
	550	-	-	-	-	12,4	12,7	13,5	13,6	14,5	15,6	16,7	17,7	17,9	18,8	19,4	19,8	20,9	21,1	21,9	22,9
	560	-	-	-	-	12,6	12,9	13,6	13,7	14,7	15,8	16,7	17,9	18,1	19,0	19,6	20,0	21,1	21,3	22,2	23,2
	600	-	-	-	-	13,1	13,5	14,2	14,4	15,4	16,5	17,7	18,8	19,0	19,9	20,5	21,0	22,1	22,3	23,2	24,3
	630	-	-	-	-	-	-	18,4	18,5	19,9	21,5	23,0	24,6	24,9	26,1	27,1	27,7	29,2	29,6	30,8	32,4
	650	-	-	-	-	-	-	18,8	19,0	20,4	22,0	23,6	25,2	25,5	26,8	27,7	28,3	29,9	30,3	31,5	33,1
	700	-	-	-	-	-	-	19,9	20,0	21,6	23,2	24,9	26,6	26,9	28,3	29,3	30,0	31,7	32,0	33,3	35,0
	710	-	-	-	-	-	-	-	20,3	21,8	23,5	25,2	26,9	27,2	28,6	29,6	30,3	32,0	32,3	33,7	35,4
	750	-	-	-	-	-	-	-	-	22,7	24,5	26,3	28,1	28,4	29,8	30,9	31,6	33,4	33,7	35,2	36,9
	800	-	-	-	-	-	-	-	-	23,9	25,8	27,6	29,5	29,9	31,4	32,5	33,2	35,1	35,5	37,0	38,9
850	-	-	-	-	-	-	-	-	-	36,0	38,9	41,2	42,3	43,3	45,4	47,5	48,5	48,9	50,6	53,4	
900	-	-	-	-	-	-	-	-	-	37,5	40,1	42,7	43,5	45,5	47,0	48,1	50,8	50,6	53,4	56,2	
950	-	-	-	-	-	-	-	-	-	-	41,7	44,6	45,5	47,6	50,1	51,7	53,0	53,4	55,7	58,8	
1000	-	-	-	-	-	-	-	-	-	-	43,5	46,5	47,7	49,4	53,0	55,1	55,2	55,3	58,2	61,1	

		B..., G...
FDS-3G (L = 325 mm)		+ 1,6
FDS-EI90S/FSD-EI120S (L = 350 mm)		+ 3,3

H0, H... m (kg ±10%)		W (mm)																
		850	900	950	1000	1050	1100	1120	1150	1200	1250	1300	1350	1400	1450	1500	1550	1600
H (mm)	100	-	-	-	-	-	-	-	-	-	-	-	-	-	-	-	-	-
	150	-	-	-	-	-	-	-	-	-	-	-	-	-	-	-	-	-
	200	21,2	22,8	24,5	26,1	28,0	29,8	31,7	33,5	34,8	34,9	35,5	36,2	36,9	37,6	38,3	-	-
	250	24,0	25,1	26,2	27,3	29,2	31,1	33,0	34,9	35,6	35,6	36,3	37,0	37,7	38,4	39,1	-	-
	300	26,5	27,7	29,0	30,2	31,5	32,7	34,0	35,2	36,1	36,6	37,8	39,0	40,2	41,3	42,5	-	-
	315	21,2	22,2	23,1	24,1	25,6	26,6	27,0	27,6	28,5	39,2	40,2	41,1	42,1	43,1	44,1	-	-
	350	22,6	23,6	24,7	25,7	27,3	28,3	28,7	29,3	30,4	40,4	41,0	42,7	45,1	47,4	49,8	-	-
	355	22,8	23,9	24,9	25,9	27,5	28,6	29,0	29,6	30,6	42,6	43,4	44,2	46,9	50,5	50,9	-	-
	400	24,6	25,7	26,9	28,0	29,7	30,8	31,2	31,9	33,0	44,1	45,2	46,3	48,8	51,4	51,8	53,2	54,6
	450	26,6	27,8	29,1	30,3	32,1	33,3	33,8	34,5	35,7	46,9	47,6	48,3	52,5	56,8	55,7	57,3	58,8
	500	28,6	29,9	31,3	32,6	34,4	35,7	36,3	37,1	38,4	51,0	52,1	53,3	56,4	59,4	59,8	60,0	60,2
	550	30,6	32,0	33,4	34,8	36,8	38,2	38,8	39,6	41,0	54,1	55,2	56,3	60,2	64,1	63,8	65,7	67,5
	560	31,0	32,5	33,9	35,3	37,3	38,7	39,3	40,1	41,6	55,5	56,2	57,0	62,2	67,4	66,6	68,0	69,3
	600	32,6	34,1	35,6	37,1	39,2	40,7	41,3	42,2	43,7	56,8	57,3	57,7	63,9	69,0	69,8	70,7	71,6
	630	33,9	35,5	37,0	38,6	40,7	42,2	42,8	43,8	45,3	66,0	67,4	68,5	69,6	70,5	71,0	72,1	73,1
	650	34,7	36,3	37,9	39,5	41,6	43,2	43,9	44,8	46,4	66,0	68,3	70,6	71,5	72,2	72,9	74,7	76,5
	700	36,7	38,4	40,1	41,8	44,0	45,7	46,4	47,4	49,1	64,0	65,2	66,4	71,5	73,9	75,7	77,9	80,0
	710	37,1	38,8	40,5	42,2	44,5	46,2	46,9	47,9	49,6	68,7	70,9	73,1	74,4	75,4	76,5	79,0	81,3
	750	38,7	40,5	42,3	44,0	46,4	48,2	48,9	49,9	51,7	73,8	75,2	73,7	76,1	78,6	79,6	81,8	83,9
	800	40,7	42,6	44,5	46,3	48,8	50,6	51,4	52,5	54,4	71,1	72,8	74,4	77,1	79,7	83,8	86,1	88,5
850	54,9	57,4	60,0	62,6	64,9	67,2	69,5	71,8	74,1	76,4	78,8	81,0	83,4	85,6	87,6	90,3	93,0	
900	57,9	60,5	63,0	65,6	68,2	70,9	72,3	73,7	76,1	78,6	81,0	83,5	86,7	90,0	91,9	94,6	97,2	
950	59,4	62,3	65,1	68,0	71,0	74,0	75,2	76,4	77,6	78,8	79,9	81,1	82,3	83,5	95,7	98,6	101,4	
1000	62,8	65,7	68,5	71,4	74,2	77,1	78,5	79,8	82,8	85,7	88,7	91,6	93,6	95,5	100,0	102,8	105,7	

		B..., G...
	FDS-3G (L = 325 mm)	+ 1,6
	FDS-EI90S/FSD-EI120S (L = 350 mm)	+ 1,6
	FDS-EI90S/FDS-EI120S (L = 350 mm)	+ 3,3

Ordering Code

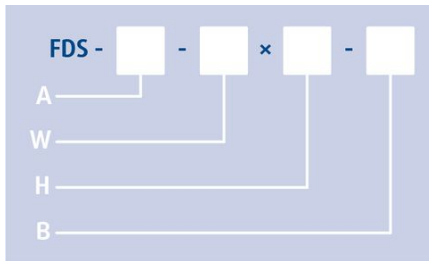

A - Damper type

3G
EI90S
EI120S

W - Width Dimension

from 100 mm up to 1200 mm (FDS-3G)
 from 450 mm up to 1600 mm (FDS-EI90S, FDS-EI120S)

H - Height Dimension

from 100 mm up to 800 mm (FDS-3G)
 from 200 mm up to 1000 mm (FDS-EI90S, FDS-EI120S)

B - Type of Activation (H0 up to G24T-SR)

- H0** - Manual crank, no switches
- H2** - Manual crank, 2 switches 230V AC or 24V AC/DC
- H5-2** - Manual crank, 24V AC/DC electromagnet, 2 switches 230V AC or 24V AC/DC
- H6-2** - Manual crank, 230V AC electromagnet, 2 switches 230V AC or 24V AC/DC
- B230T** - 230V AC Belimo Actuator
- G230T** - 230V AC Gruner Actuator
- B24T** - 24V AC/DC Belimo Actuator
- G24T** - 24V AC/DC Gruner Actuator
- B24T-W** - 24V AC/DC Belimo Actuator & Wire connector for comm.unit
- G24T-W** - 24V AC/DC Gruner Actuator & Wire connector for comm.unit
- BST0** - 230V AC supply and communication unit BKN230-24 & 24V AC/DC Belimo spring return Actuator
- GST0** - 24V AC/DC supply and communication unit FSC-UFC24-2 (Modbus/BACnet) & 24V AC/DC Gruner spring return Actuator
- BST1** - SLC powered supply and communication unit BC24-G2 (THC) & 24V AC/DC Belimo spring return actuator
- BST2** - 230 V AC supply and communication unit BKN230-24-MOD (Modbus/BACnet) & 24V AC/DC Belimo spring return actuator
- BST3** - 230 V AC supply and communication unit BKN230-24-C-MP (SBS/MP) & 24V AC/DC Belimo spring return actuator
- BST10** - 230 V AC supply and communication unit BKN230-24-PL (Powerline) & 24V AC/DC Belimo spring return actuator

Modulated activation types only for dimensions from WxH=160x160 mm up to WxH=1200x800 mm.

B24T-SR - 24V AC/DC Belimo spring return actuator, modulated (0)2 V ... 10 V

G24T-SR - 24V AC/DC Gruner spring return actuator, modulated (0)2 V ... 10 V

Example of the Rectangular Fire Dampers Ordering Code

FDS-3G

FDS-3G-1200x800-H5-2 Rectangular fire damper, nominal dimensions width × height = 1200 × 800 mm, with open and closed position indication with 230 V contact microswitches.

Note: The fire resistivity depends on the installation method.

FDS-EI90S, FDS-EI120S

FDS-EI120S-1600x1000-B24T Rectangular fire damper with fire resistivity EI120S, nominal dimensions width × height = 1600 × 1000 mm, with a 24V Belimo actuator and a thermoelectric fuse.

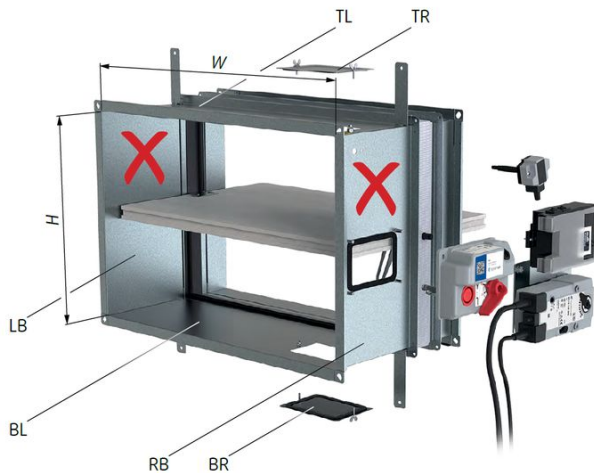

Inspection opening positions

(Removable mechanism is available for all sizes)

W and H < 200

No inspection opening. Inspection possible through removable mechanism or additional inspection opening must be added to the connecting duct.

W and H ≥ 200

Standardly in position: BR and TR; On demand in positions: TL*, BL.

H ≥ 250

Standardly in position: BR, TR; On demand in position: TL*, LB, BL.



































W > 800

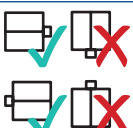



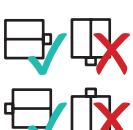



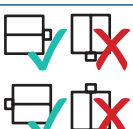





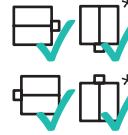
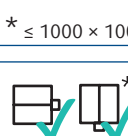



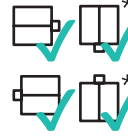
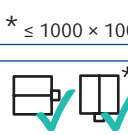

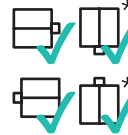
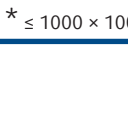

Standardly in position: BR, TR; On demand in position: TL*, LB, RB, BL.

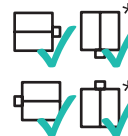
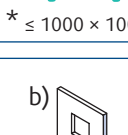
NOTES:

* An inspection lid cannot be placed on position BR and BL on one damper. ** An inspection lid cannot be placed on position TL and TR on one damper.

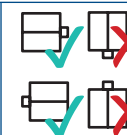
Installation Methods

 1 Wet	FDS-3G 100 × 100 1200 × 800	EI 60 ($v_e h_o i \leftrightarrow o$) S	a)  b)  c) 	 360°
		EI 90 ($v_e h_o i \leftrightarrow o$) S		
		EI 120 ($v_e h_o i \leftrightarrow o$) S		
 2 Dry	FDS-3G 100 × 100 1200 × 800	EI 60 ($v_e h_o i \leftrightarrow o$) S	a)  b)  c) 	 360°
		EI 90 ($v_e h_o i \leftrightarrow o$) S		
 3 Soft	FDS-3G 100 × 100 1200 × 800	EI 60 ($v_e i \leftrightarrow o$) S	a)  b) 	 360°
		EI 90 ($v_e i \leftrightarrow o$) S		
		EI 60 ($h_o i \leftrightarrow o$) S	c) 	
		EI 90 ($h_o i \leftrightarrow o$) S		
		EI 120 ($h_o i \leftrightarrow o$) S		
 3H Hilti	FDS-3G 100 × 100 1200 × 800	EI 60 ($v_e - i \leftrightarrow o$) S	a)  b) 	 360°
 5.1 On, Out	FDS-3G 100 × 100 1200 × 800	EI 60 ($v_e - i \leftrightarrow o$) S	a)  b) 	
		EI 90 ($v_e - i \leftrightarrow o$) S		
 5.2 On, Out	FDS-3G 100 × 100 1200 × 800	EI 60 ($v_e - i \leftrightarrow o$) S	a)  b) 	
 5.3 On, Out	FDS-3G 100 × 100 1200 × 800	EI 60 ($v_e - i \leftrightarrow o$) S	a)  b) 	
		EI 90 ($v_e - i \leftrightarrow o$) S		
 5.4 On, Out	FDS-3G 100 × 100 1200 × 800	EI 60 ($v_e - i \leftrightarrow o$) S	a)  b) 	

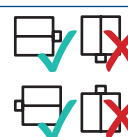
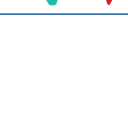
 1 Wet	FDS-EI90S $W \leq 1600 \ \& \ H \leq 1000$	EI 90 ($v_e \ h_o \ i \leftrightarrow o$) S	a) 	b) 	c) 	  $* \leq 1000 \times 1000$
	FDS-EI120S $W \leq 1600 \ \& \ H \leq 1000$	EI 120 ($v_e \ h_o \ i \leftrightarrow o$) S				
 2 Dry	FDS-EI90S $W \leq 1600 \ \& \ H \leq 1000$	EI 90 ($v_e \ h_o \ i \leftrightarrow o$) S	a) 	b) 	c) 	  $* \leq 1000 \times 1000$
	FDS-EI120S $W \leq 1600 \ \& \ H \leq 1000$	EI 120 ($v_e \ h_o \ i \leftrightarrow o$) S				
 3 Soft	FDS-EI90S $W \leq 1600 \ \& \ H \leq 1000$	EI 90 ($v_e \ h_o \ i \leftrightarrow o$) S	a) 	b) 	c) 	  $* \leq 1000 \times 1000$
	FDS-EI120S $W \leq 1600 \ \& \ H \leq 1000$	EI 120 ($h_o \ i \leftrightarrow o$) S	c) 	  $* \leq 1000 \times 1000$		
 5.1 On, Out	FDS-EI90S $W \leq 1600 \ \& \ H \leq 1000$	EI 90 ($v_e - i \leftrightarrow o$) S	a) 	b) 	 	
	FDS-EI120S $W \leq 1600 \ \& \ H \leq 1000$	EI 120 ($h_o - i \leftrightarrow o$) S				
 7 Multi	FDS-EI90S $W \leq 1600 \ \& \ H \leq 1000$	EI 90 ($v_e - i \leftrightarrow o$) S	b) 	 		
	FDS-EI120S $W \leq 1600 \ \& \ H \leq 1000$	EI 120 ($h_o - i \leftrightarrow o$) S				

Legend:

- 1. **Wet** - Wet installation, using Plaster/Mortar/Concrete Filling
- 2. **Dry** - Dry installation, using cover boards and mineral wool filing
- 3. **Soft** - Soft installation, using mineral wool filing
- 3H. **Hilti** - Filling made only from Hilti foam
- 5.1. **On & Out** - ON & OUT of the wall installation rated for EI90S, Using 2 layers of Mineral Wool
- 5.2. **On & Out** - ON & OUT of the wall installation rated for EI60S, Using 1 layer of Mineral Wool
- 5.3. **On & Out** - ON & OUT of the wall installation rated for EI90S, Using Promatect boards
- 5.4. **On & Out** - ON & OUT of the wall installation rated for EI60S, Using Promatect boards
- 7. **Multi** - Multiple damper installation rated for EI90S, using a set of FDS-EI90S fire dampers
- a) - Flexible (plasterboard) wall
- b) - Concrete/masonry/cellular concrete (rigid) wall
- c) - Concrete/cellular concrete (rigid) floor/ceiling
- v_e - Vertical wall
- h_o - Horizontal floor/ceiling

Installation, Maintenance & Operation

Some damper parts may have sharp edges – therefore to protect yourself from harm, please use gloves during damper installation and manipulation. In order to prevent electric shock, fire or any other damage which could result from incorrect damper usage and operation, it is important to:

1. ensure that installation is performed by a trained person.
2. follow the written and depicted instructions provided within Handbook closely.
3. perform damper inspection in accordance with Handbook.
4. check the damper's functionality as per the chapter "Fire Damper Functionality Check" before you install the fire damper. This procedure prevents the installation of a damper that has been damaged during transportation or handling.

Information about installation, maintenance and operation is available in the "Handbook_FDR-3G" document or more can be found at SystemairDESIGN.

Installation rules

- The duct connected to the fire damper must be supported or hung in such a way that the damper does not carry its weight. The damper must not support any part of the surrounding construction or wall which could cause damage and consequent damper failure. It is recommended to connect the damper to a dilatation compensator on either end of the damper.
- The damper driving mechanism can be placed on either side of the wall, however, it needs to be placed so as to ensure easy access during inspection.
- According to the standard EN 1366-2, the distance between the fire damper bodies must be at least 200 mm. This condition does not apply for tested distances. Therefore Wet and Soft installations are approved for smaller distances under condition that the resulted resistivity is reduced to EI90S.
- The distance between the wall/ceiling and the fire damper must be at least 75 mm. This condition does not apply for tested distances. Therefore Wet and Soft installations are approved for smaller distances under condition that the resulted resistivity is reduced to EI90S.
- The fire damper must be installed into a fire partition structure in such a way that the damper blade in its closed position is located inside this structure. A bendable hinge is provided on the damper body which represents a plane where supporting construction begins. This condition does not apply for installations On & Out.
- For each resistivity the minimum thickness of its supporting construction cannot be decreased as per EN 1366-2 at least 200 mm from the installation opening.
- The gap in the installation opening between the fire damper and the wall/ceiling can be increased by up to 50% of the gap area, or decreased to the smallest amount possible that still provides sufficient space for the installation of the filling.

IN ACCORDANCE WITH EN 15650, EACH FIRE DAMPER MUST BE INSTALLED ACCORDING TO THE INSTALLATION INSTRUCTIONS PROVIDED BY THE MANUFACTURER!

Wet Installation

Using Plaster/Mortar/Concrete Filling

Important: Use support inside the damper when adding filling. The weight of the filling can damage or bend the damper casing.

1. The supporting construction opening must be prepared as depicted. Opening surfaces must be even and cleaned off. The flexible wall opening must be reinforced as per the standards for plasterboard walls. The opening dimensions are driven by the nominal dimensions of the damper with added clearance. For rectangular dampers, the opening will have the dimensions of W1 and H1.
2. Insert the closed damper into the middle of the opening so that the damper blade is in the wall. Use the bendable hanger (2; or hangers) to secure the damper against the wall using a suitable screw (F1; recommended screw diameter 5,5; e.g. DIN7981).
3. For damper widths greater than 800 mm, it is recommended to use a duct support inside the damper to avoid any damage, bend to the damper housing from the weight of the filling.
4. Fill in the area between the wall and the damper with plaster or mortar or concrete filling (2), while paying attention to prevent the fouling of the damper's functional parts, which could limit its correct functionality. The best way is to cover the functional parts during installation. The seepage of the filling material can be prevented by using boards. However, these are not required for wet installation.

First let the plaster or mortar or concrete filling harden and then perform the next steps!

5. After the filling hardens, remove the duct support from inside of the damper.
6. If needed, uncover and clean the damper after installation.
7. Check the damper's functionality

Installation Standard Distances





According to the standard EN 1366-2, the minimum distance from the wall or ceiling to the damper body is 75 mm. For multiple crossings through a fire-resistive wall the minimum distance between two damper bodies is 200 mm. This applies to distances between the damper and a nearby foreign object crossing the fire-resistive wall.





Installation - Smaller Distances - Maximum resistivity reduced to EI90S

The distance between 2 individual fire dampers can be reduced to 60 mm, measured from surface to surface of the housing and the distance between the surface of the damper installed in the duct and the adjacent supporting construction (wall/floor) can be reduced to 40 mm, provided that the fire resistance classification will be reduced as follows: EI90 (ve i ↔ o) S.

Installation in a Wall thinner than tested

Installation in a thinner wall is allowed under the condition that an additional layer/layers of fire protective board are fixed to the surface of the wall in order to achieve the same length of damper penetration seal as was tested. The minimum width of added boards around the damper is 200 mm. In addition, the alternative thinner wall should be classified in accordance with EN 13501-2:2007 + A1: 2009 for fire-resistance required for product application. For a protruding wall, the additional layers must be fixed on the steel supporting construction of the wall.

 1 Wet	FDS-3G	EI 60 (v _e h _o i ↔ o) S				 360°
	100 × 100 ...	EI 90 (v _e h _o i ↔ o) S				
	... 1200 × 800	EI 120 (v _e h _o i ↔ o) S				

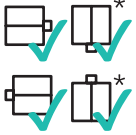
 1 Wet	FDS-EI90S $W \leq 1600 \ \& \ H \leq 1000$	EI 90 ($v_e \ h_o \ i \leftrightarrow o$) S	a) 	b) 	c) 	 * $\leq 1000 \times 1000$
	FDS-EI120S $W \leq 1600 \ \& \ H \leq 1000$	EI 120 ($v_e \ h_o \ i \leftrightarrow o$) S				

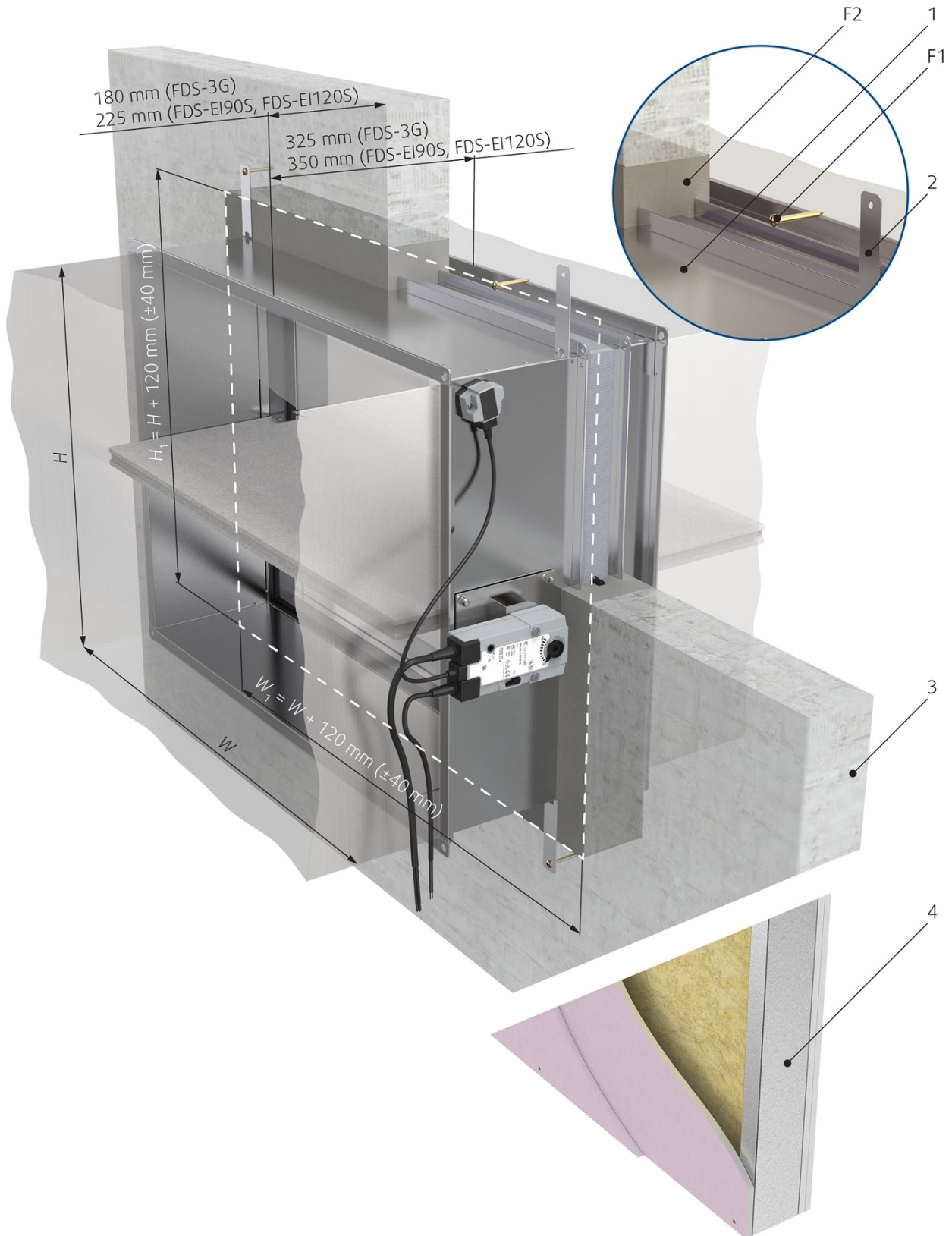

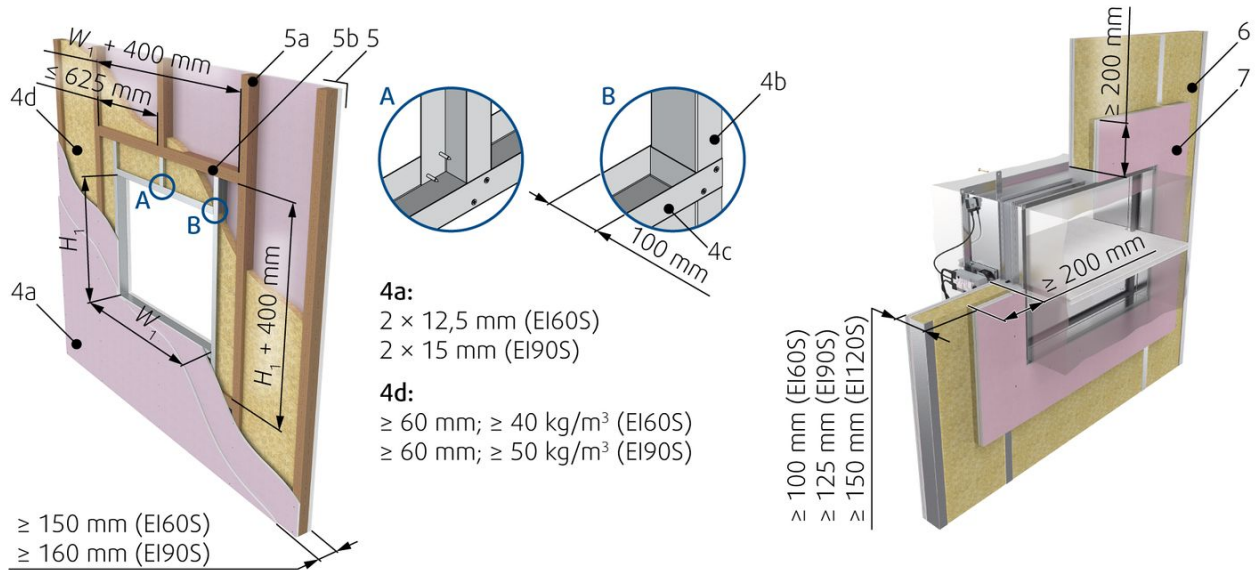
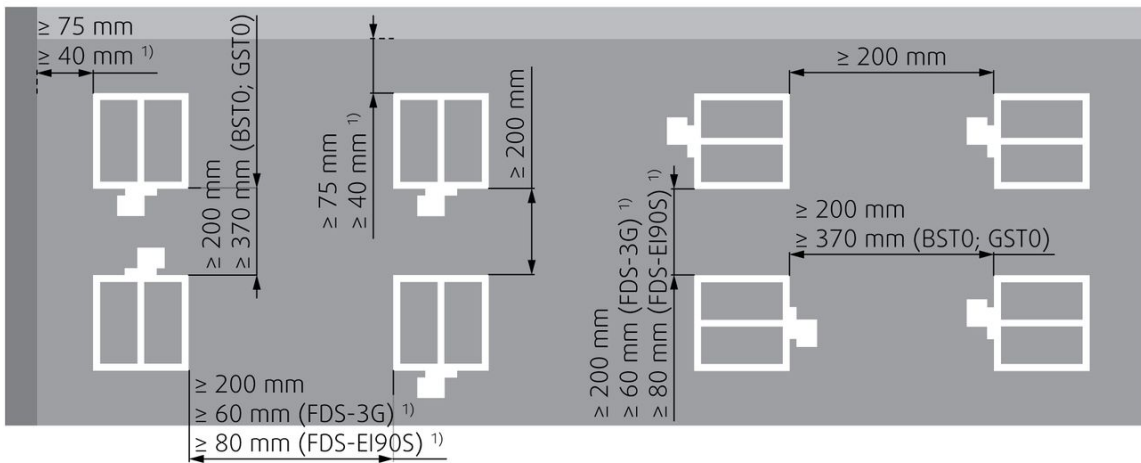
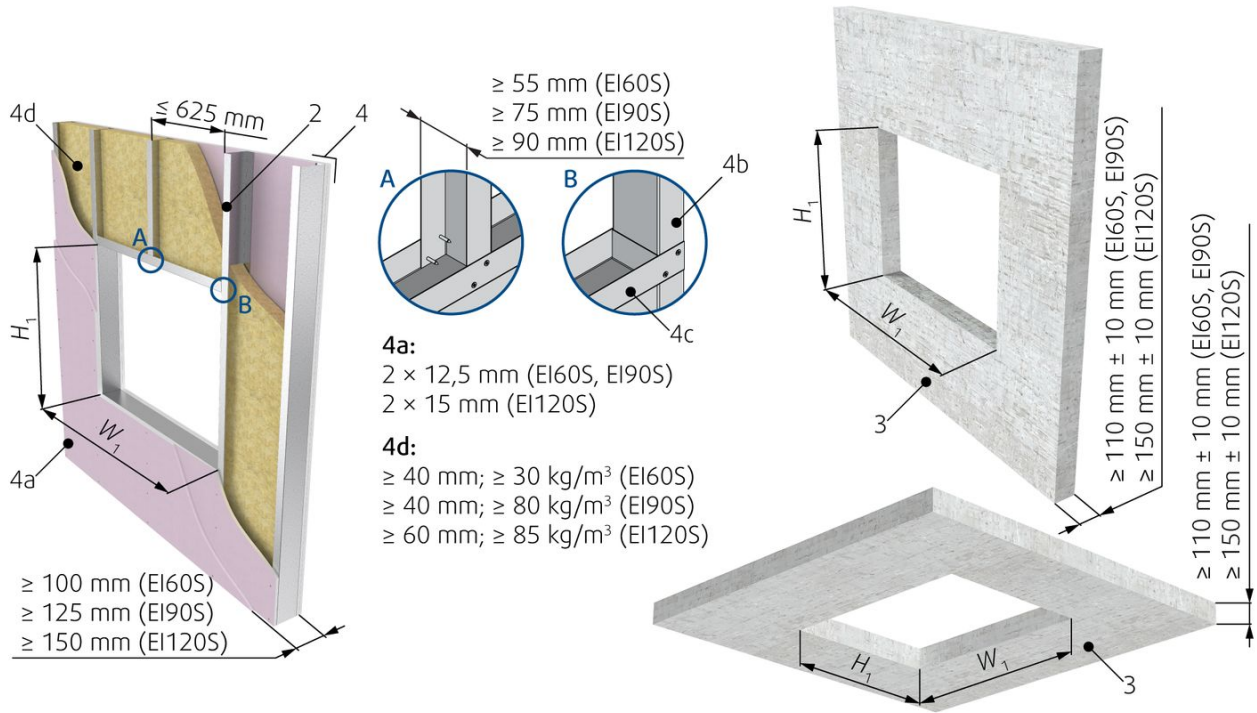

Legend

- F1** Screw $\geq 5,5$ DIN7981 or suitable wall plug and screw size 6.
- F2** Plaster/mortar/concrete filling
- 1** Fire damper (actuator side)
- 2** Bendable hanger
- 3** Concrete/masonry/cellular concrete wall or ceiling
- 4** Flexible (plasterboard) wall
- 4a** 2 layers of plasterboard fireproof plate type F, EN 520
- 4b** Vertical CW – profiles
- 4c** Horizontal CW – profiles
- 4d** Mineral wool; thickness/cubic density see picture.
- 5** Flexible (wood beam) wall
- 5a** Vertical spruce wooden beam $\geq 60 \times 100$ mm
- 5b** Horizontal spruce wooden beam $\geq 80 \times 100$ mm
- 6** Alternative thinner wall (classified in accordance with EN 13501-2:2007 + A1: 2009 for fire resistance required for product application)
- 7** Area of 200 mm from opening around the damper must have the same composition and be created the same way as Flexible (plasterboard) wall.

Notes

- a)** - Flexible (plasterboard) wall
- b)** - Concrete/masonry/cellular concrete (rigid) wall
- c)** - Concrete/cellular concrete (rigid) floor/ceiling
- v_e** - Vertical wall
- h_o** - Horizontal floor/ceiling
- 1)** Smaller distances – resistivity must be reduced to EI90 (ve i<->o) S

Dry Installation

Using Mineral Wool and Cover Boards









1. The supporting construction opening must be prepared as depicted. Opening surfaces must be even and cleaned off. The flexible wall opening must be reinforced as per the standards for plasterboard walls. The opening dimensions are driven by the nominal dimensions of the damper with added clearance. For rectangular dampers, the opening will have dimensions of W1 and H1.
2. With FDS-3G dampers it is necessary to install the bendable hangers (2) onto the cover boards using suitable screws or screws with wall plug (F1). With FDS-EI90S dampers it is necessary to install the bendable hangers (2) onto the supporting construction (below the cover boards) using suitable screws or screws with wall plug (F1). Insert the damper from the mechanism side and secure the bendable hangers of the damper into the cover board (FDS-3G) or onto the wall (FDS-EI90S) using suitable screws (F1). Subsequently mount the remaining cover boards from the mechanism side.
3. Fill in the area between the wall and the damper with mineral wool (F3) with a density of at least 50 kg/m³ thoroughly but in such a way that will not deform the damper housing, while paying attention to prevent the fouling of the damper's functional parts, which could limit its correct functionality.
4. Close the gap between the damper and the mounting opening, for a circular damper use CBR-FD cover boards, for a rectangular damper use CBS-FD cover boards with screws (F1) through pre-drilled holes.
5. All the gaps between the cover boards, between cover boards and the wall and between cover boards and the fire damper need to be filled with fire-resistive coating (F4).
6. If needed, uncover and clean the damper after installation.
7. Check the damper's functionality

Installation Standard Distances

For Dry installation, the minimum distance from the wall or ceiling to the damper body is 150 mm. For multiple crossings through a fire-resistive wall the minimum distance between two damper bodies is 300 mm. Distances between the damper and a nearby foreign object crossing the fire-resistive wall is 200 mm.

Installation in a Wall thinner than tested

Installation in a thinner wall is allowed under the condition that an additional layer/layers of fire protective board are fixed to the surface of the wall in order to achieve the same length of damper penetration seal as was tested. The minimum width of added boards around the damper is 200 mm. In addition, the alternative thinner wall should be classified in accordance with EN 13501-2:2007 + A1: 2009 for fire-resistance required for product application. For a protruding wall, the additional layers must be fixed on the steel supporting construction of the wall.

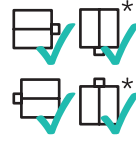
 2 Dry	FDS-3G 100 × 100 1200 × 800	EI 60 ($v_e h_o i \leftrightarrow o$) S EI 90 ($v_e h_o i \leftrightarrow o$) S	a) 	b) 	c) 	 360°
 2 Dry	FDS-EI90S W ≤ 1600 & H ≤ 1000	EI 90 ($v_e h_o i \leftrightarrow o$) S	a) 	b) 	c) 	 * ≤ 1000 × 1000

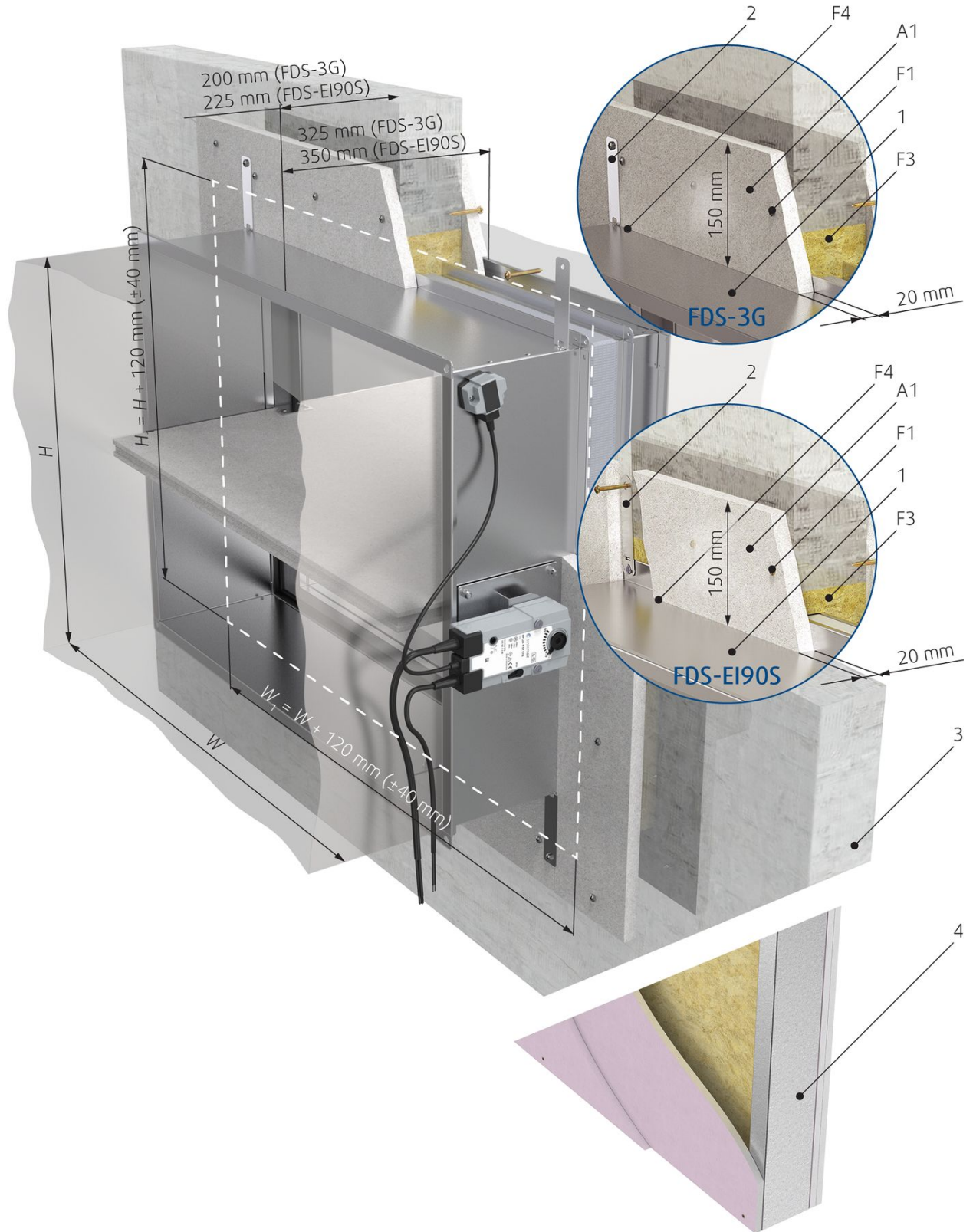

Legend

- F1** Screw $\geq 5,5$ DIN7981 or suitable wall plug and screw size 6.
- F3** Mineral wool filling (min. 50 kg/m³)
- F4** Fire resistive coating, e.g. Promastop-CC/Promat
- A1** Cover board CBS-FD (accessory) obligatory
- 1** Fire damper (actuator side)
- 2** Bendable hanger
- 3** Concrete/masonry/cellular concrete wall or ceiling
- 4** Flexible (plasterboard) wall
- 4a** 2 layers of plasterboard fireproof plate type F, EN 520
- 4b** Vertical CW – profiles
- 4c** Horizontal CW – profiles
- 4d** Mineral wool; thickness/cubic density see picture.
- 5** Flexible (wood beam) wall
- 5a** Vertical spruce wooden beam $\geq 60 \times 100$ mm
- 5b** Horizontal spruce wooden beam $\geq 80 \times 100$ mm
- 6** Alternative thinner wall (classified in accordance with EN 13501-2:2007 + A1: 2009 for fire resistance required for product application)
- 7** Area of 200 mm from opening around the damper must have the same composition and be created the same way as Flexible (plasterboard) wall.

Notes:

- a)** - Flexible (plasterboard) wall
- b)** - Concrete/masonry/cellular concrete (rigid) wall
- c)** - Concrete/cellular concrete (rigid) floor/ceiling
- v_e** - Vertical wall
- h_o** - Horizontal floor/ceiling

Soft installation

Installation into a Soft Crossing with fire-resistive coating

With this installation we recommend using flexible connection (see accessory FCR) due to thermal expansion of connected ducts during fire. Install the compensator so, that the flexible part has a minimum distance of 50 mm from the edge of a damper's blade in open position.

1. The supporting construction opening must be prepared as depicted. Opening surfaces must be even and cleaned off. The flexible wall opening must be reinforced as per the standards for plasterboard walls. The opening dimensions are driven by the nominal dimensions of the damper with added clearance. For rectangular dampers, the opening will have the dimensions of W1 and H1.
2. Prepare mineral wool installation segments (F5) with thickness of the opening height. First apply a suitable fire-resistive coating (F6) onto the damper at the place of its future placement, assemble and glue the filling of the future installation with the same fire-resistive coating. After the fire-resistive coating has dried, the damper and the filling are ready for installation.
3. Apply the same fire-resistive coating (F6) onto the internal surface of the wall opening. Also apply the fire-resistive coating on the external surface of the filling glued on the damper surface. Immediately after the fire-resistive coating is applied, place the damper into the wall opening. The damper blade must be located in the supporting structure.
4. After inserting the damper into the opening and fixing it using the bendable hangers and suitable screws (F1), apply the same fire-resistive coating (F6), at least 2 mm thick and 100 mm wide, on the exposed filling and wall edges evenly from both sides. Do not apply this layer in the place where the mechanism is located, inspection openings and manufacturer labels.
5. **Applies only to FDS-EI90S, FDS-EI120S damper types:** It is necessary to fix the dampers installed in a wall using four steel L-profiles (F7) from above and below. Anchor the profiles to the wall on each end using at least one screw (F1) and self-drilling screws (F8) against the damper with a maximum of 200 mm gaps.
6. **Applies only to FDS-EI90S, FDS-EI120S damper types:** Dampers installed into a ceiling need to be fixed onto the ceiling using two steel L-profiles (F7) from above. Anchor the profiles to the ceiling on each end using at least one screw (F1) and self-drilling screws (F8) against the damper with a maximum of 200 mm gaps.
7. If needed, uncover and clean the damper after installation.
8. Check the damper's functionality

Installation - Standard Distances













According to the standard EN 1366-2, the minimum distance from the wall or ceiling to the damper body is 75 mm. For multiple crossings through a fire-resistive wall the minimum distance between two damper bodies is 200 mm. This applies to distances between the damper and a nearby foreign object crossing the fire-resistive wall.

Installation - Smaller Distances

The distance between 2 individual fire dampers can be reduced to 60 mm, measured from surface to surface of the housing and the distance between the surface of the damper installed in the duct and the adjacent supporting construction (wall/floor) can be reduced to 40 mm.

Installation in a Wall thinner than tested

Installation in a thinner wall is allowed under the condition that an additional layer/layers of fire protective board are fixed to the surface of the wall in order to achieve the same length of damper penetration seal as was tested. The minimum width of added boards around the damper is 200 mm. In addition, the alternative thinner wall should be classified in accordance with EN 13501-2:2007 + A1: 2009 for fire-resistance required for product application. For a protruding wall, the additional layers must be fixed on the steel supporting construction of the wall.

 <p>3 Soft</p>	<p>FDS-3G</p> <p>100 × 100 1200 × 800</p>	<p>EI 60 ($v_e i \leftrightarrow o$) S</p>	<p>a) </p>	<p>b) </p>	 <p>360°</p>	
		<p>EI 90 ($v_e i \leftrightarrow o$) S</p>				
		<p>EI 60 ($h_o i \leftrightarrow o$) S</p>	<p>c) </p>			
		<p>EI 90 ($h_o i \leftrightarrow o$) S</p>				
		<p>EI 120 ($h_o i \leftrightarrow o$) S</p>				
 <p>3 Soft</p>	<p>FDS-EI90S</p> <p>$W \leq 1600$ & $H \leq 1000$</p>	<p>EI 90 ($v_e h_o i \leftrightarrow o$) S</p>	<p>a) </p>	<p>b) </p>	<p>c) </p>	 <p>* $\leq 1000 \times 1000$</p>
	<p>FDS-EI120S</p> <p>$W \leq 1600$ & $H \leq 1000$</p>	<p>EI 120 ($h_o i \leftrightarrow o$) S</p>	<p>c) </p>	 <p>* $\leq 1000 \times 1000$</p>		

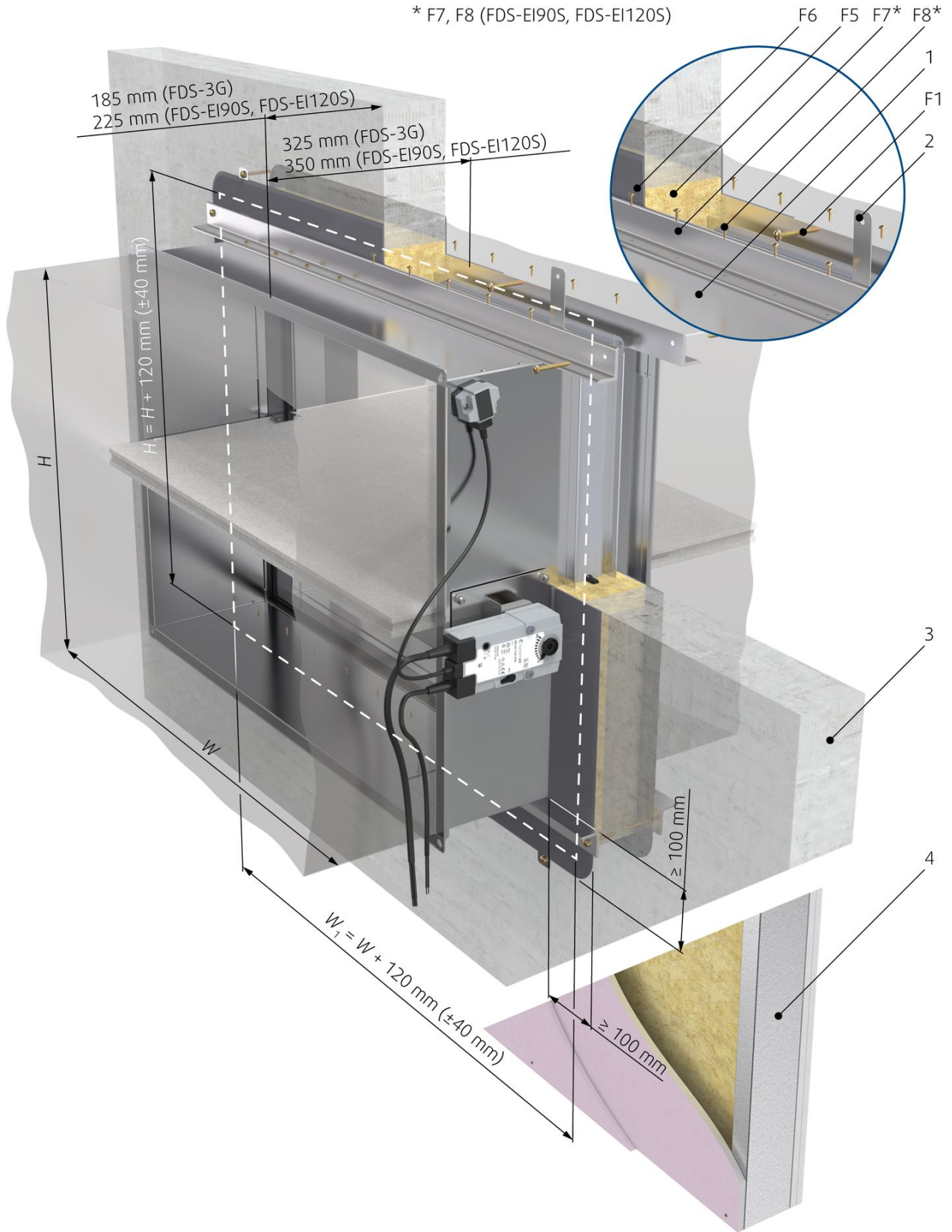

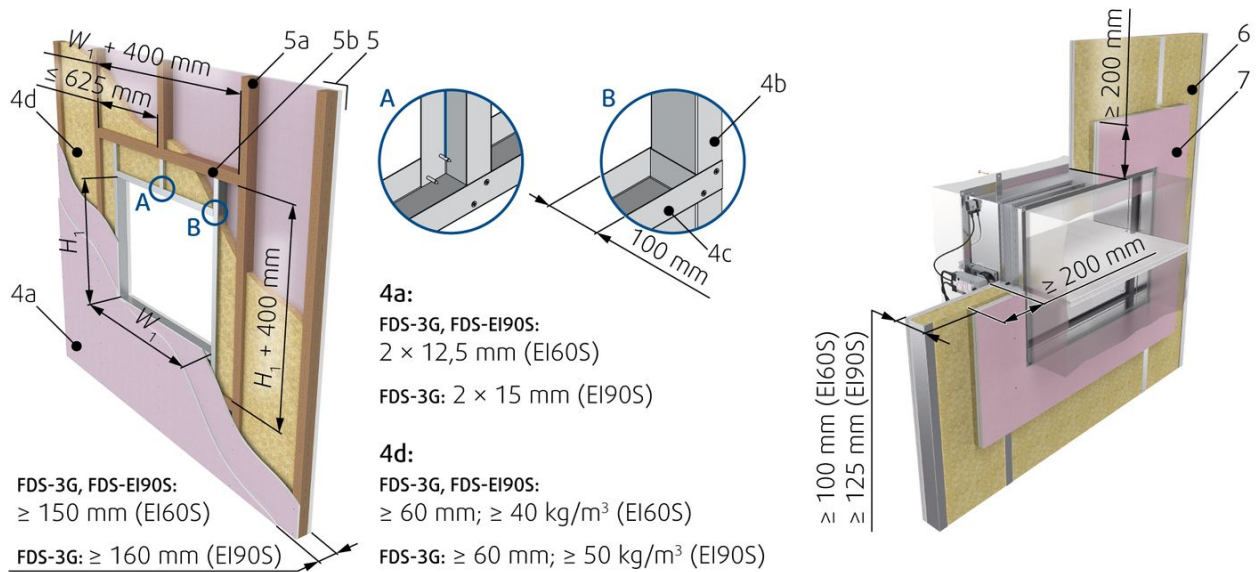
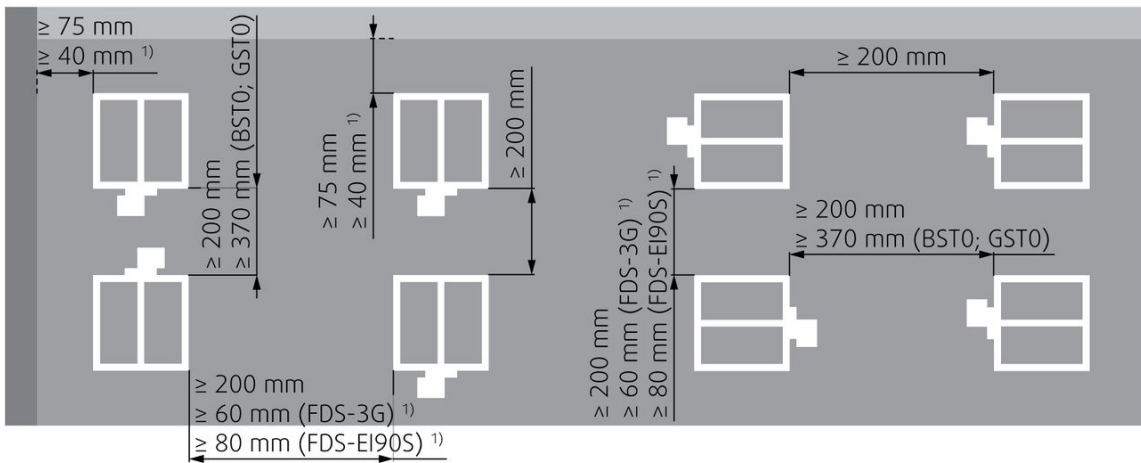
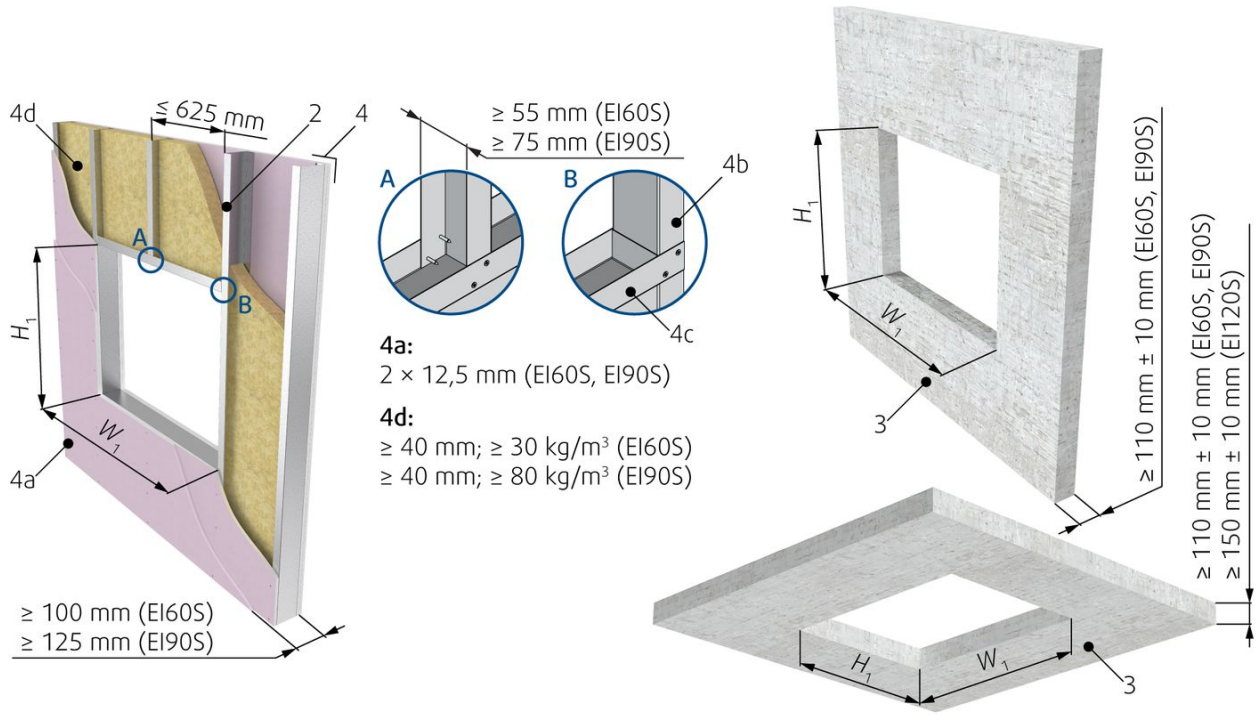

Legend

- F1** Screw $\geq 5,5$ DIN7981 or suitable wall plug and screw size 6.
- F5** Mineral wool segment (minimum 150 kg/m³).
- F6** Layer of fire resistive coating (Promastop-CC/Promat) at least 2 mm thick for exposed surfaces.
- F7** Only for FDS-EI90S, FDS-EI120S dampers: L-profile 60 × 40 × 3 mm, length W + 300 mm or WL + 300 mm
- F8** Only for FDS-EI90S, FDS-EI120S dampers: Screw 3,9 × max. 13 DIN7504
- 1** Fire damper (actuator side)
- 2** Bendable hanger
- 3** Concrete/masonry/cellular concrete wall or ceiling
- 4** Flexible (plasterboard) wall
 - 4a** 2 layers of plasterboard fireproof plate type F, EN 520
 - 4b** Vertical CW – profiles
 - 4c** Horizontal CW – profiles
 - 4d** Mineral wool; thickness/cubic density see picture.
- 5** Flexible (wood beam) wall
 - 5a** Vertical spruce wooden beam $\geq 60 \times 100$ mm
 - 5b** Horizontal spruce wooden beam $\geq 80 \times 100$ mm
- 6** Alternative thinner wall (classified in accordance with EN 13501-2:2007 + A1: 2009 for fire resistance required for product application)
- 7** Area of 200 mm from opening around the damper must have the same composition and be created the same way as Flexible (plasterboard) wall.

Notes:

- a)** - Flexible (plasterboard) wall
- b)** - Concrete/masonry/cellular concrete (rigid) wall
- c)** - Concrete/cellular concrete (rigid) floor/ceiling
- v_e** - Vertical wall
- h_o** - Horizontal floor/ceiling
- 1)** Smaller distances – resistivity maximum EI90 ($v_e \leftrightarrow o$) S

Installation Hilti

Filling made only from Hilti foam

With this installation we recommend using flexible connection (see accessory FCR) due to thermal expansion of connected ducts during fire. Install the compensator so, that the flexible part has a minimum distance of 50 mm from the edge of a damper's blade in open position.

Tip: Excess material can be reused as the filling for this installation. It can be inserted into the cavity before you add new foam from the gun.

1. The supporting construction opening must be prepared as depicted. Opening surfaces must be even and cleaned off. The flexible wall opening must be reinforced as per the standards for plasterboard walls. The opening dimensions are driven by the nominal dimensions of the damper with added clearance. For rectangular dampers, the opening will have the dimensions of W1 and H1.
2. Insert the damper into the opening concentric and fixing it with the opening using the bendable hangers and suitable screws (F1).
3. Wear protective gloves when handling foam. Insert the barrel of the foam gun into the middle of the cavity between damper and opening and fill it completely with foam (F17) pushed out foam can be quickly hand pushed back into the cavity.
4. After the filling (F17) is solidified, though it will always remain partly flexible, you can cut the excess foam that stands out from the wall.
5. If needed, uncover and clean the damper after installation.
6. Check the damper's functionality

Installation - Standard Distances





According to the standard EN 1366-2, the minimum distance from the wall or ceiling to the damper body is 75 mm. For multiple crossings through a fire-resistive wall the minimum distance between two damper bodies is 200 mm. This applies for distances between the damper and a nearby foreign object crossing the fire-resistive wall.

Installation - Smaller Distances

The distance between 2 individual fire dampers can be reduced to 60 mm, measured from surface to surface of the housing and the distance between the surface of the damper installed in the duct and the adjacent supporting construction (wall/floor) can be reduced to 40 mm.

Installation in a Wall thinner than tested

Installation in a thinner wall is allowed under the condition that an additional layer/layers of fire protective board are fixed to the surface of the wall in order to achieve the same length of damper penetration seal as was tested. The minimum width of added boards around the damper is 200 mm. In addition, the alternative thinner wall should be classified in accordance with EN 13501-2:2007 + A1: 2009 for fire-resistance required for product application. For a protruding wall, the additional layers must be fixed on the steel supporting construction of the wall.

 3H Hilti	FDS-3G 100 × 100 1200 × 800	EI 60 ($v_e - i \leftrightarrow o$) S	a) 	b) 	 360°
---	---	---	--	---	---

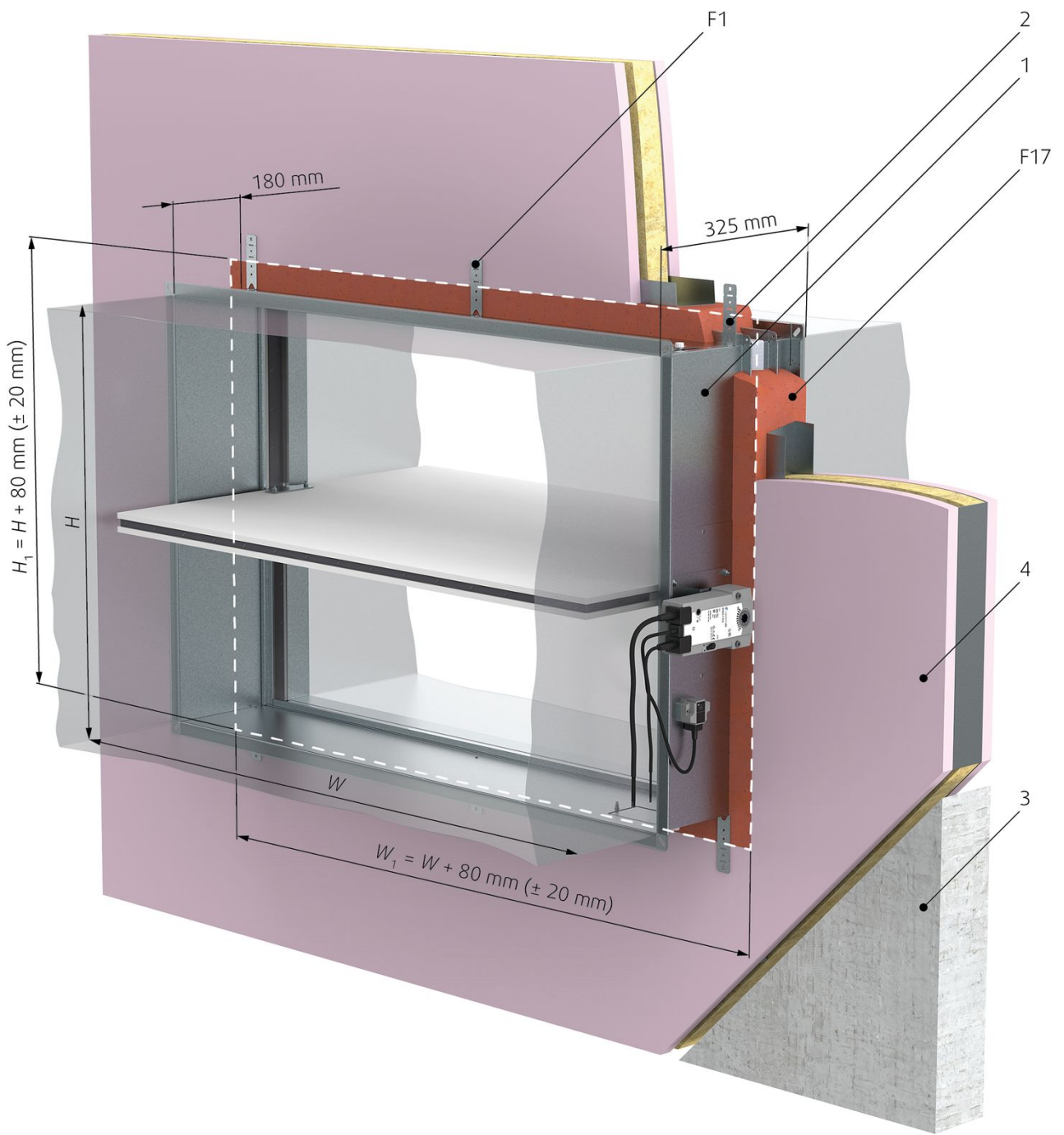

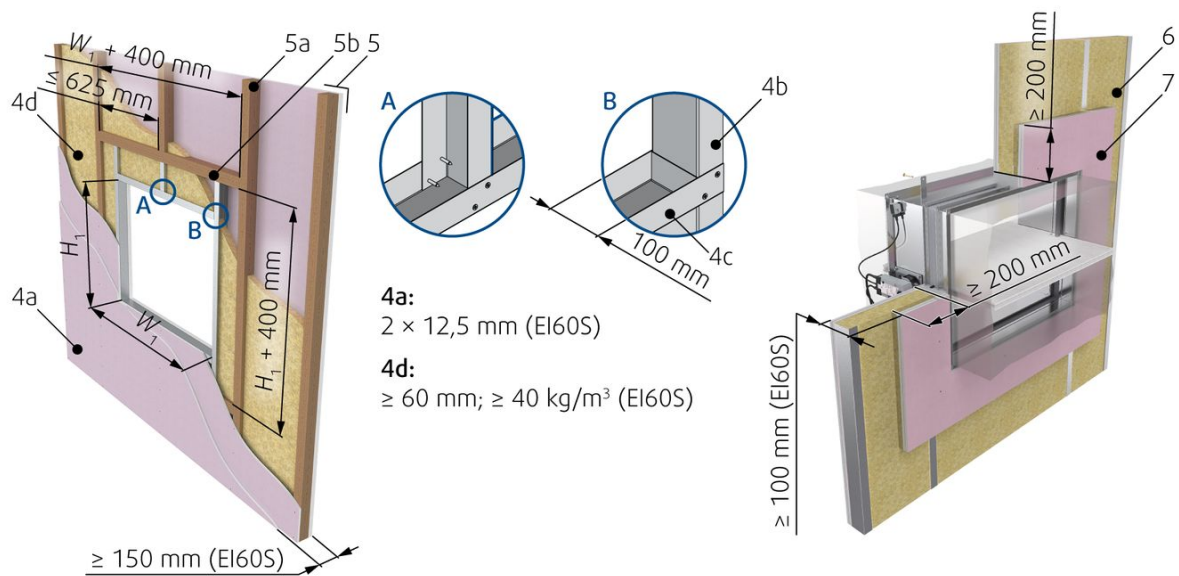
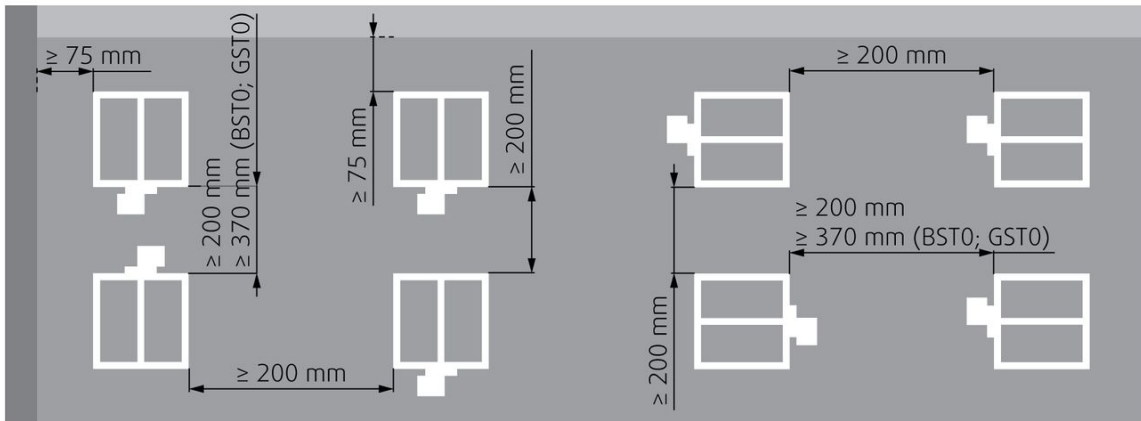
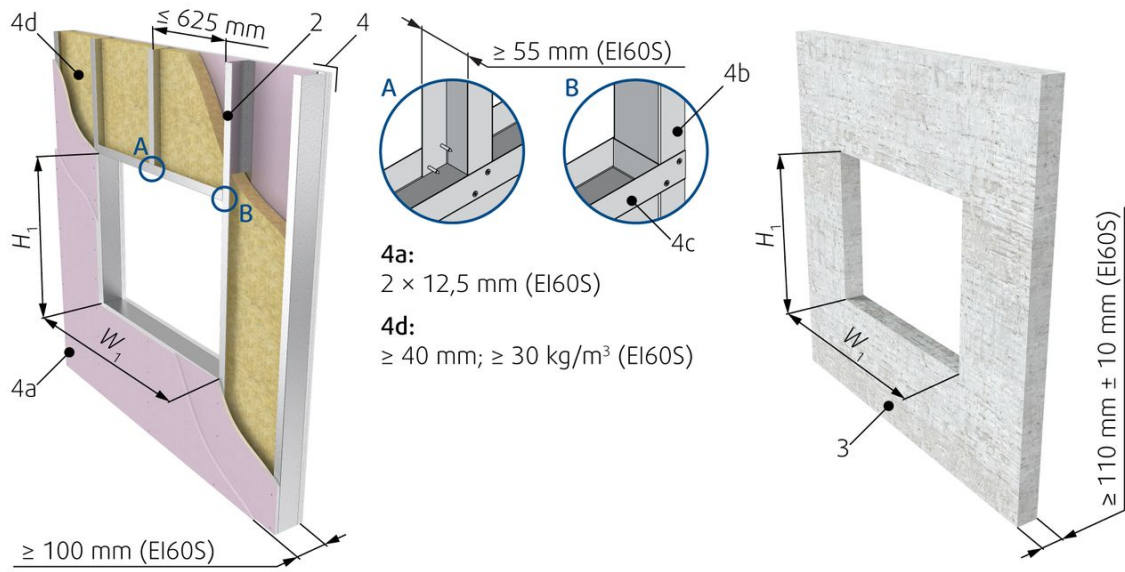

Legend

- F1** Screw $\geq 5,5$ e.g. DIN7981 or suitable wall plug and screw size 6.
- F17** Foam CFS-F FX/HILTI.
- 1** Fire damper (actuator side)
- 2** Bendable hanger
- 3** Concrete/masonry/cellular concrete wall or ceiling
- 4** Flexible (plasterboard) wall
 - 4a** 2 layers of plasterboard fireproof plate type F, EN 520
 - 4b** Vertical CW – profiles
 - 4c** Horizontal CW – profiles
 - 4d** Mineral wool; thickness/cubic density see picture.
- 5** Flexible (wood beam) wall
 - 5a** Vertical spruce wooden beam $\geq 60 \times 100$ mm
 - 5b** Horizontal spruce wooden beam $\geq 80 \times 100$ mm
- 6** Alternative thinner wall (classified in accordance with EN 13501-2:2007 + A1: 2009 for fire resistance required for product application)
- 7** Area of 200 mm from opening around the damper must have the same composition and be created the same way as Flexible (plasterboard) wall.

Notes:

- a)** - Flexible (plasterboard) wall
- b)** - Concrete/masonry/cellular concrete (rigid) wall
- v_e** - Vertical wall
- 1)** Smaller distances – maximum resistivity EI90 ($v_e \leftrightarrow o$) S

ON & OUT of the wall installation, EI90S

Using 2 layers of Mineral Wool

TIP: The duct-wall cavity filling can be also replaced by plaster/mortar/concrete (F2) as a replacement of filling (F9), then the coating (F10) is not needed for the cavity filling.

1. The supporting construction opening must be prepared as depicted. Opening surfaces must be even and cleaned off. The flexible wall opening must be reinforced as per the standards for plasterboard walls. The opening dimensions are driven by the nominal dimensions of the damper with added clearance. For rectangular dampers, the opening will have the dimensions of W1 and H1.
2. Insert the duct into the load-bearing structure along with the damper in such a way that the duct will stick out of the wall to the needed distance. Press the insulation around the duct (F9) and cut its edges to even it with the wall surface. Paint the insulation surface in alignment with the wall with a suitable coat of paint (F10) up to 100 mm from the duct to cover the insulation and part of the wall. Or use filling (F2) as per WET installation.
3. Hang the square damper, surrounded in its perimeter with U-profiles (22) or tubular frame, in the blade location onto the threaded rods (20) min. M10.
4. Insulate the damper and duct parts between the damper and the wall. Glue the insulation onto the wall using suitable fire-resistive coating (F10).
5. Secure the insulation:
 - for FDS-3G onto the square duct in two 90 mm layers. Using 90 mm (1st layer) and 180 mm (2nd layer) long welding pins (18, 19).
 - for FDS-EI90S onto the square duct in two 100 mm layers. Using 100 mm (1st layer) and 200 mm (2nd layer) long welding pins (18, 19).
6. Cover the insulation face and perimeter up to 150 mm from the insulation edge using galvanized sheet metal (accessory A3), secure the sheet against the damper housing through accessories holes. Any protruding screws which could stand in the way of the blade during its opening need to be shortened so that they don't prevent blade movement.
7. If needed, uncover and clean the damper after installation.
8. Make sure the fixing screws are not interfering with the blade movement and check the damper's functionality.





Duct rules



The rules for hanger placement and duct suspension depend on the damper's distance from the supporting construction. The desired distance from the wall to the end of the duct connection with the damper divides the rules into two groups:

- Distance from 35 mm to max. 1500 mm.
- Distance greater than 1500 mm

Installation Distances

For installation 5.1 ON & OUT, the minimum distance from the wall or ceiling to the damper body is 40 mm. For multiple crossings through a fire-resistive wall the minimum distance between two damper bodies is 400 mm. The distance of 200 mm applies for distances between the damper and a nearby foreign object crossing the fire-resistive wall.

 5.1 On, Out	FDS-3G	EI 60 ($v_e - i \leftrightarrow o$) S	a) 	b) 	
	100 × 100 1200 × 800	EI 90 ($v_e - i \leftrightarrow o$) S			

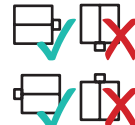
 <p>5.1 On, Out</p>	<p>FDS-EI90S $W \leq 1600$ & $H \leq 1000$</p>	<p>EI 90 (v_e - i ↔ o) S</p>	<p>a) </p>	<p>b) </p>	
--	---	--	---	--	---

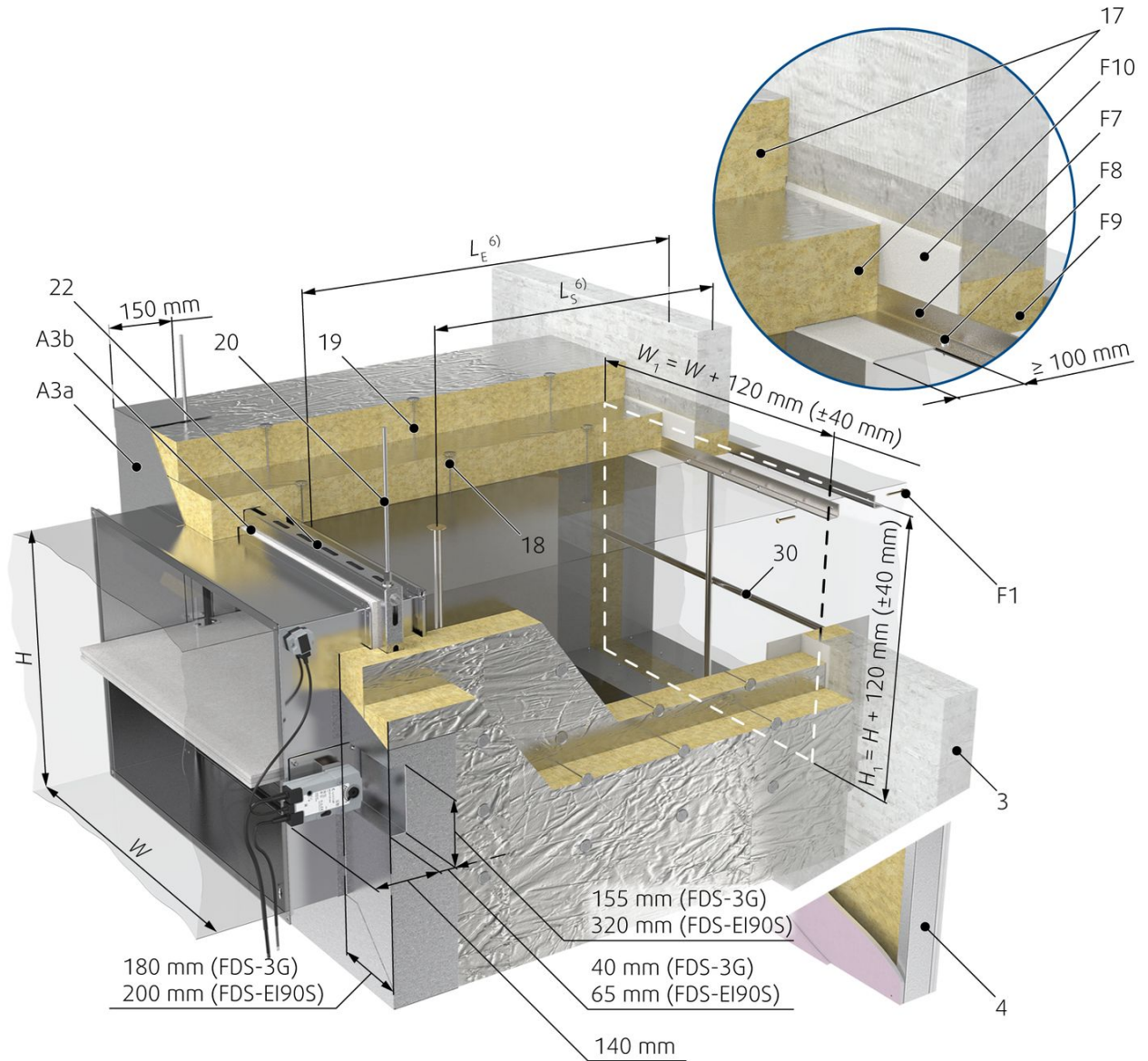

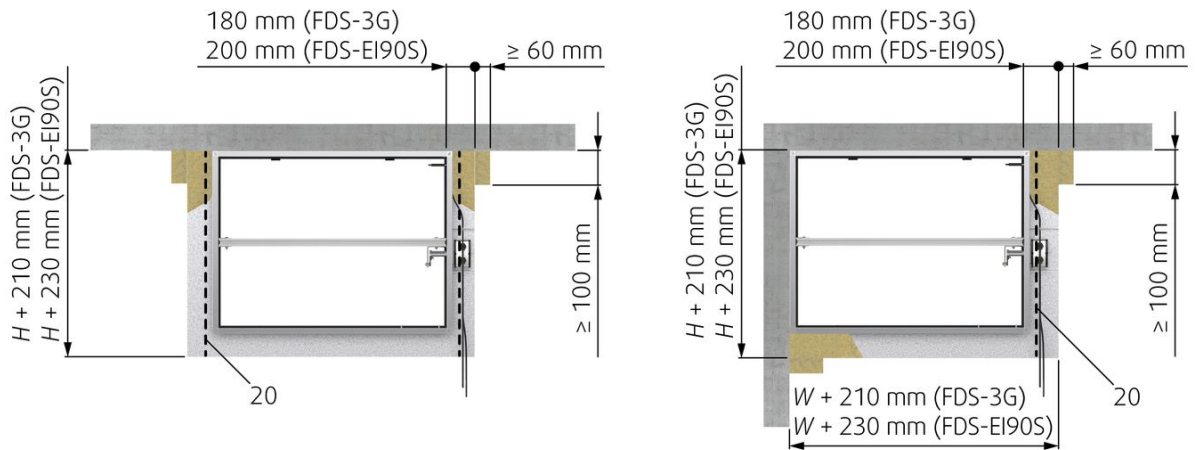
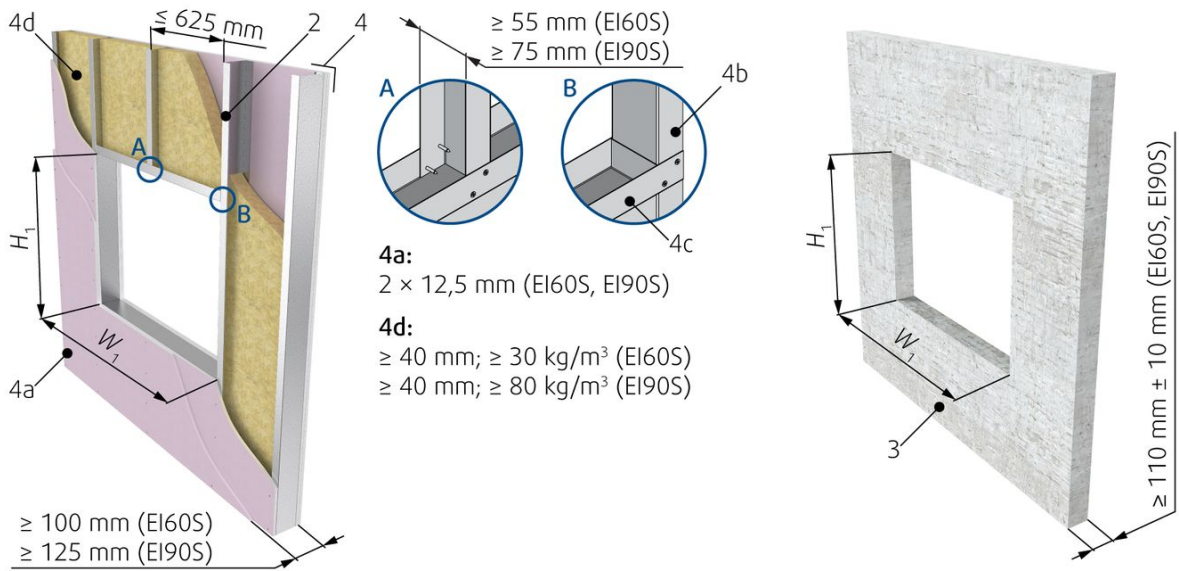
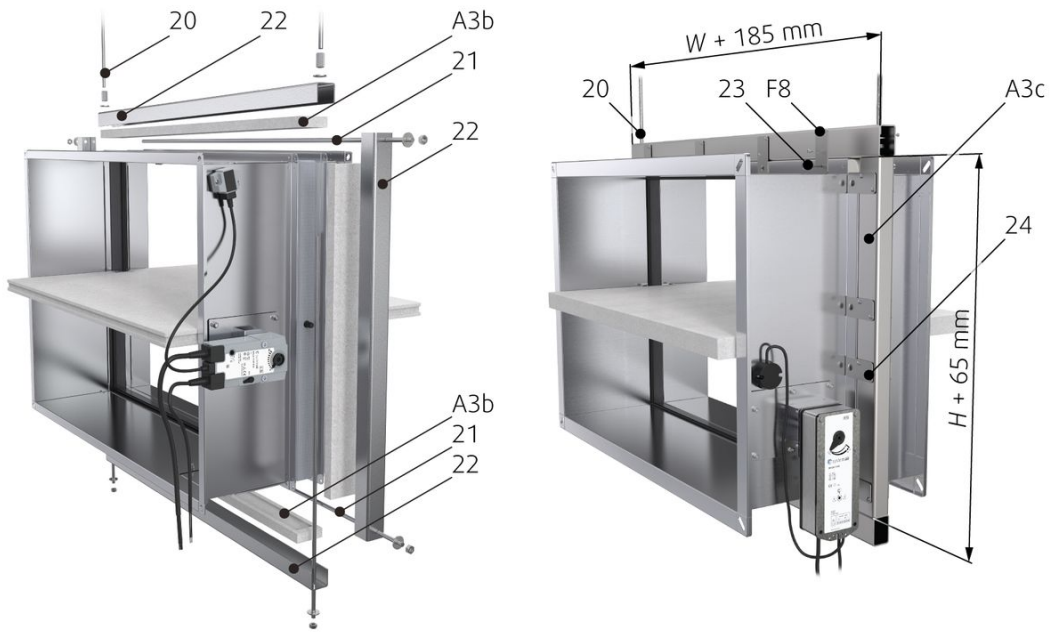

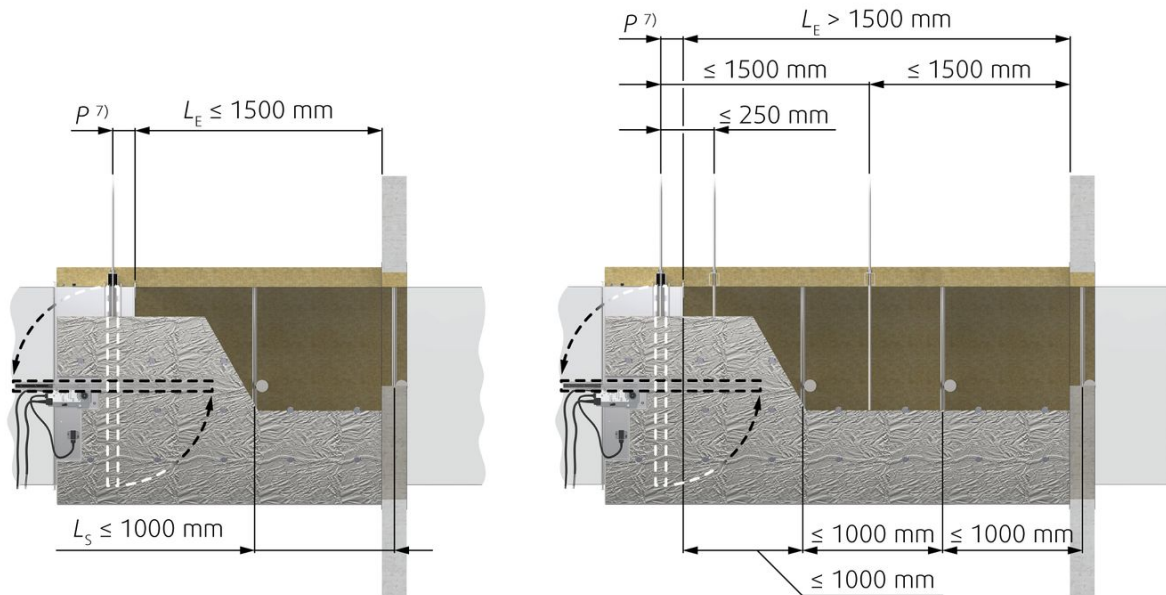

Legend

- F1** Screw $\geq 5,5$ DIN7981 or suitable wall plug and screw size 6.
- F7** L-profile $60 \times 40 \times 3$ mm, length $W + 300$ mm or $WL + 300$ mm
- F8** Screw $3,9 \times \max. 13$ DIN7504
- F9** Mineral wool segment (min. 66 kg/m^3) - in a wall
- F10** Layer of fire resistive coating (BSF/ISOVER) at least 2 mm thick for exposed surfaces
- F11** Sheet metal belt 40×2 mm bent into an L shape of 35 and 160 mm
- A3** IPOS-FD-W×H (also available as an accessory)
 - A3a** Insulation front cover; min. thickness 0,9 mm
 - A3b** Calcium silicate board 60×20 mm
 - A3c** Steel frame made from HILTI profile; e.g. MQ31 (for FDS-3G) or tubular profiles $60 \times 40 \times 3$ mm for (FDS-EI90S)
- 1** Fire damper (actuator side)
- 3** Concrete/masonry/brick/cellular concrete wall or ceiling
- 4** Flexible (plasterboard) wall
 - 4a** 2 layers of plasterboard fireproof plate type F, EN 520
 - 4b** Vertical CW – profiles
 - 4c** Horizontal CW – profiles
 - 4d** Mineral wool; thickness/cubic density see picture.
- 17** Mineral wool segment ULTIMATE Protect Slab 4.0 Alu1/ISOVER (min. 66 kg/m^3) - inner layer & outer layer
- 18** Welding pin, length 180 or 200 mm - Top without welding pins, side 20 pins/m², bottom 20 pins/m²; distance between pins max. 250 mm, distance of the pin from the edge 80 mm
- 19** Welding pin – length 90 or 100 mm - Top without welding pins, side 20 pins/m², bottom 20 pins/m²; distance between pins max. 250 mm, distance of the pin from the edge 80 mm
- 20** Steel threaded rod M10
- 21** Steel threaded rod M8
- 22** U-profile (MQ31/HILTI)
- 23** Damper insulation frame's screw
- 24** Sheet metal plate $85 \times 40 \times 2,5$ mm

Notes

- a) - Flexible (plasterboard) wall

b) - Concrete/masonry/cellular concrete (rigid) wall

v_e - Vertical wall

(5) Rules for hanger placements and duct suspensions depend on the dampers distance from the supporting construction LE

(7) The distance P is the distance from the blade axis to the damper flange. The distance depends on the type of damper used.

(6) Rules for hanger placements LP and duct suspensions LS depend on the damper's distance from the supporting construction LE

F2 Plaster/mortar/concrete filling - can serve as replacement of filling F9. Using Plaster/mortar/concrete filling the coating F10 is not needed.

5.2 ON & OUT of the wall installation, EI60S

Using 1 layer of Mineral Wool

TIP: The duct-wall cavity filling can be also replaced by plaster/mortar/concrete (F2) as a replacement of filling (F9), then the coating (F10) is not needed for the cavity filling.

Damper Preparation before Installation: Fasten the rectangular damper in the blade/perforation location only on the top and bottom sides with U-profiles (28), and then fasten the U-profiles together by using the threaded rod M10 (20).

1. The supporting construction opening must be prepared as depicted. Opening surfaces must be even and cleaned off. The flexible wall opening must be reinforced as per the standards for plasterboard walls. The opening dimensions are driven by the nominal dimensions of the damper with added clearance. For rectangular dampers, the opening will have the dimensions of W1 and H1.
2. Insert the duct into the load-bearing structure along with the damper in such a way that the duct will stick out of the wall to the needed distance. Press the insulation around the duct (F9) and cut its edges to even it with the wall surface. Paint the insulation surface in alignment with the wall with a suitable coat of paint (F10) up to 100 mm from the duct to cover the insulation and part of the wall. Or use filling (F2) as per WET installation.
3. Reinforce the rectangular duct with stiffening rods (30) along the insulated duct. The first cross is placed on the wall, the others at distances of LS.
4. Insulate the damper and duct parts between the damper and the wall. Glue the insulation (29) in one 80 mm layer onto the wall around the duct by using a suitable fire-resistive coating (F10). Secure the insulation (29) using 80 mm long welding pins (27). The actuator, thermosensor, and inspection lid must remain uninsulated with a gap of a maximum of 20 mm.
5. Around the front side and on all surfaces that are not covered with aluminum foil, apply aluminum tape (25).
6. If needed, uncover and clean the damper after installation.
7. Make sure the fixing screws are not interfering with the blade movement and check the damper's functionality.



Duct rules

The rules for hanger placement and duct suspension depend on the damper's distance from the supporting construction. The desired distance from the wall to the end of the duct connection with the damper divides the rules into two groups:

- Distance from 35 mm to max. 1500 mm
- Distance greater than 1500 mm

Installation Distances

For installation 5.2 ON & OUT, the minimum distance from the wall or ceiling to the damper body is 40 mm. For multiple crossings through a fire-resistive wall the minimum distance between two damper bodies is 200 mm. The distance of 200 mm also applies for distances between the damper and a nearby foreign object crossing the fire-resistive wall.

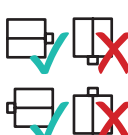
 FDS-3G 100 × 100 1200 × 800 5.2 On, Out		EI 60 ($v_e - i \leftrightarrow o$) S	a) 	b) 	
--	--	---	--	---	---

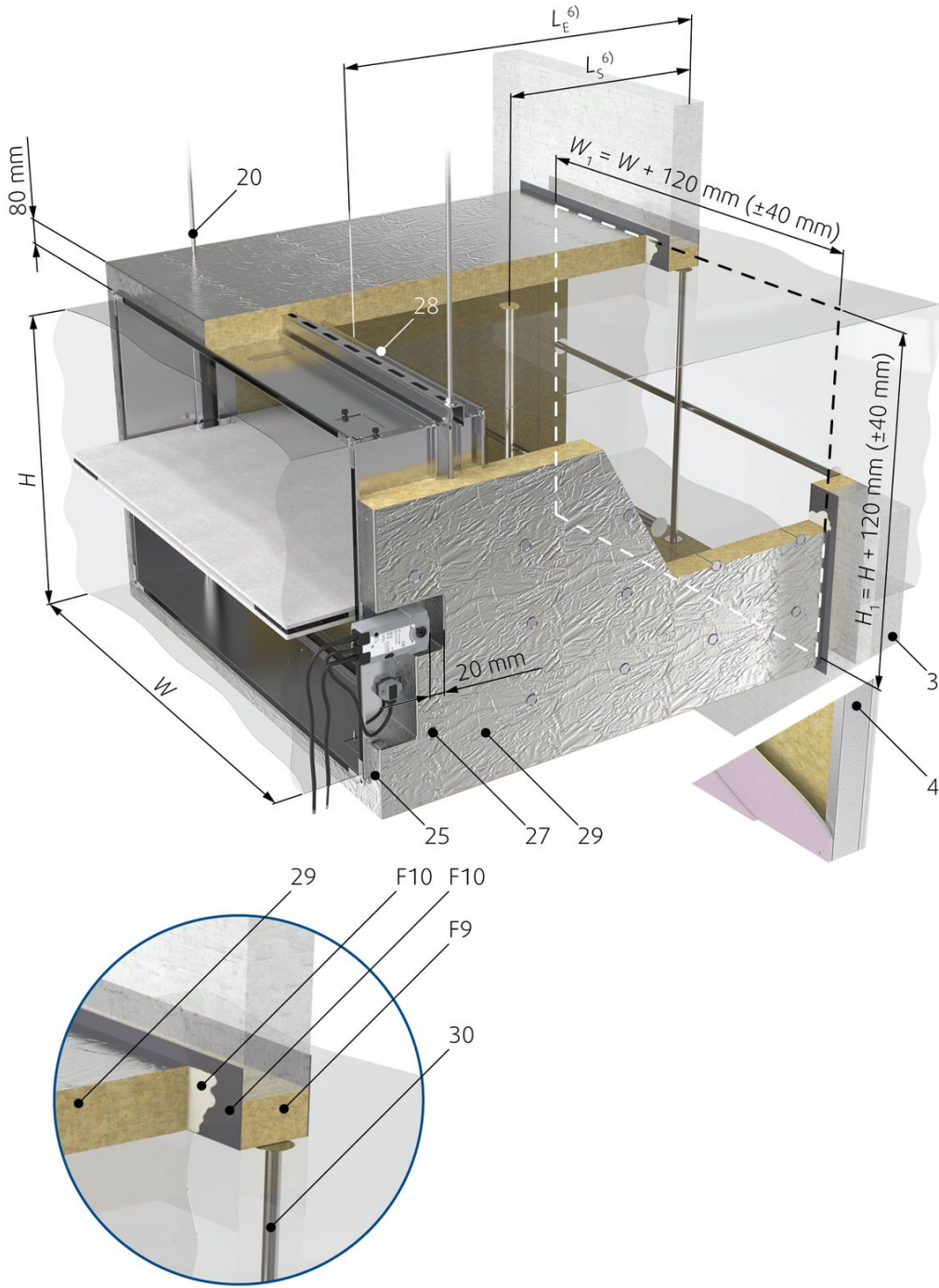

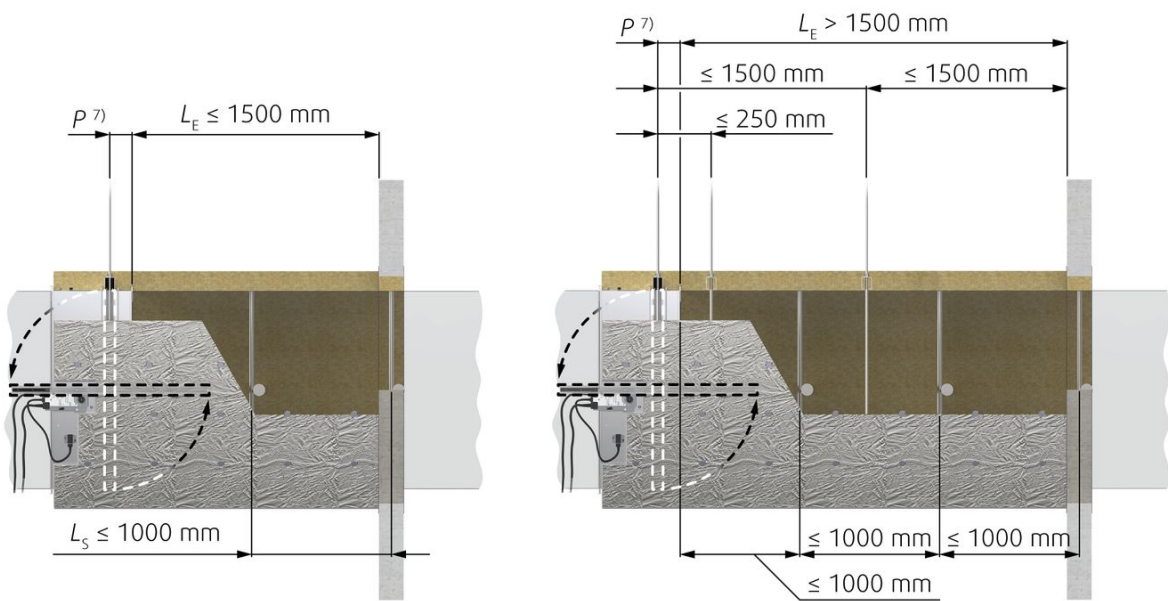
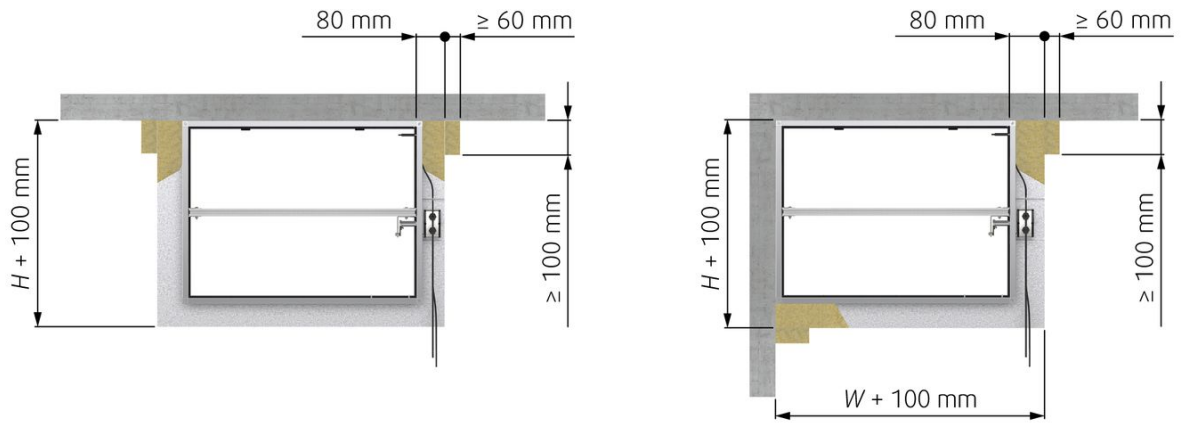
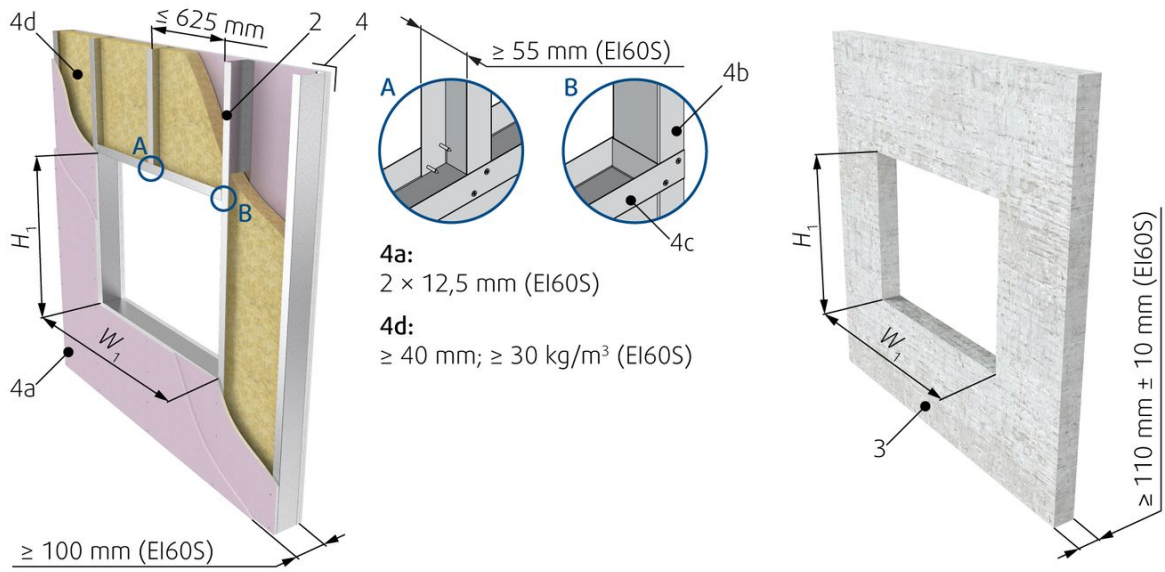

Legend

- F9** Mineral wool segment (min. 66 kg/m³) - in a wall
- F10** Layer of fire resistive coating (BSF/ISOVER) at least 2 mm thick for exposed surfaces
- 1** Fire damper (actuator side)
- 3** Concrete/masonry/brick/cellular concrete wall or ceiling
- 4** Flexible (plasterboard) wall
 - 4a** 2 layers of plasterboard fireproof plate type F, EN 520
 - 4b** Vertical CW – profiles
 - 4c** Horizontal CW – profiles
 - 4d** Mineral wool; thickness/cubic density see picture.
- 20** Steel threaded rod M10
- 25** Aluminium tape around the front side and on places uncovered with alufoil
- 27** Welding pin – length 80 mm - Top without welding pins, side 20 pins/m², bottom 20 pins/m²; distance between pins max. 250 mm, distance of the pin from the edge 80 mm
- 28** U-profile (MQ31/HILTI) - top and bottom
- 29** Mineral wool segment thickness 80 mm (min. 66 kg/m³; ISOVER Ultimate U-Protect Slab 4.0 Alu1)
- 30** Stiffening rods: horizontal for W > 600 mm; vertical for H > 400 mm

Notes

- a)** - Flexible (plasterboard) wall
- b)** - Concrete/masonry/cellular concrete (rigid) wall
- v_e** - Vertical wall
- (5)** Rules for hanger placements and duct suspensions depend on the dampers distance from the supporting construction LE
- (6)** Rules for hanger placements LP and duct suspensions LS depend on the damper's distance from the supporting construction LE
- (7)** The distance P is the distance from the blade axis to the damper flange. The distance depends on the type of damper used.
- **F2Plaster/mortar/concrete filling - can serve as replacement of filling F9. Using Plaster/mortar/concrete filling the coating F10 is not needed.

5.3 ON & OUT of the wall installation, maximum EI90S

Using Promatect Boards

TIP: The duct-wall cavity filling (F12) and its coating (F13) can be also replaced by plaster/mortar/concrete (F2).

Damper Preparation before Installation: Attach all 4 parts of the IKOWS-FD accessory around the casing where the damper blade is situated, as shown in picture and apply a suitable fire-resistive coating (F13) to the contact surfaces of the boards and the damper. Fasten them together using the screws included in the IKOWS-FD package.

1. The supporting construction opening must be prepared as depicted. Opening surfaces must be even and cleaned off. The flexible wall opening must be reinforced as per the standards for plasterboard walls. The opening dimensions are driven by the nominal dimensions of the damper with added clearance. For rectangular dampers, the opening will have the dimensions of W1 and H1.
2. Insert the duct into the load-bearing structure along with the damper in such a way that the duct will stick out of the wall to the needed distance. Press the insulation around the duct (F12) and cut its edges to even it with the wall surface.
3. Paint the insulation surface in alignment with the wall with a suitable coat of paint (F13) up to 100 mm from the duct to cover the insulation and part of the wall. Or use filling (F2) as per WET installation.
4. Fit 4 boards (F15) of 100 mm in width around the duct and secure them using suitable screws (F1) to the wall; fasten an L-profile (F14) to the wall and the duct on the damper side; fasten 4 boards (32) by joining them together in corners by screws.
5. Cover the IKOWS-FD accessory (A4) and the boards (32) along the entire length with 40 mm thick boards (31); apply fire-resistive coating (F13) to all joints and fix with screws (33).
6. Bind the damper in the blade location using a profile (34) at the top and bottom damper side, using threaded rods (20) and nuts. The threaded rods are to be at a distance of max. 50 mm from the side insulation surface.
7. If needed, uncover and clean the damper after installation.
8. Make sure the fixing screws are not interfering with the blade movement and check the damper's functionality.



Duct rules

The rules for hanger placement and duct suspension depend on the damper's distance from the supporting construction. The desired distance from the wall to the end of the duct connection with the damper divides the rules into two groups:

- Distance from 35 mm to max. 1500 mm.
- Distance greater than 1500 mm.

Installation Distances

For installation 5.3 ON & OUT, the minimum distance from the wall or ceiling to the damper body is 40 mm. For multiple crossings through a fire-resistive wall the minimum distance between two damper bodies is 200 mm. The distance of 200 mm applies for distances between the damper and a nearby foreign object crossing the fire-resistive wall.

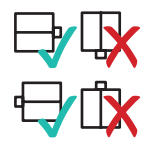
 FDS-3G 100 × 100 ... 5.3 On, Out ... 1200 × 800	EI 60 ($v_e - i \leftrightarrow o$) S	a) 	b) 	
	EI 90 ($v_e - i \leftrightarrow o$) S			

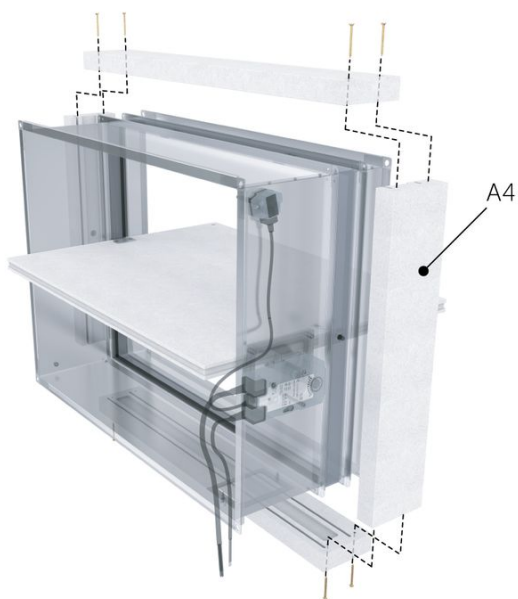
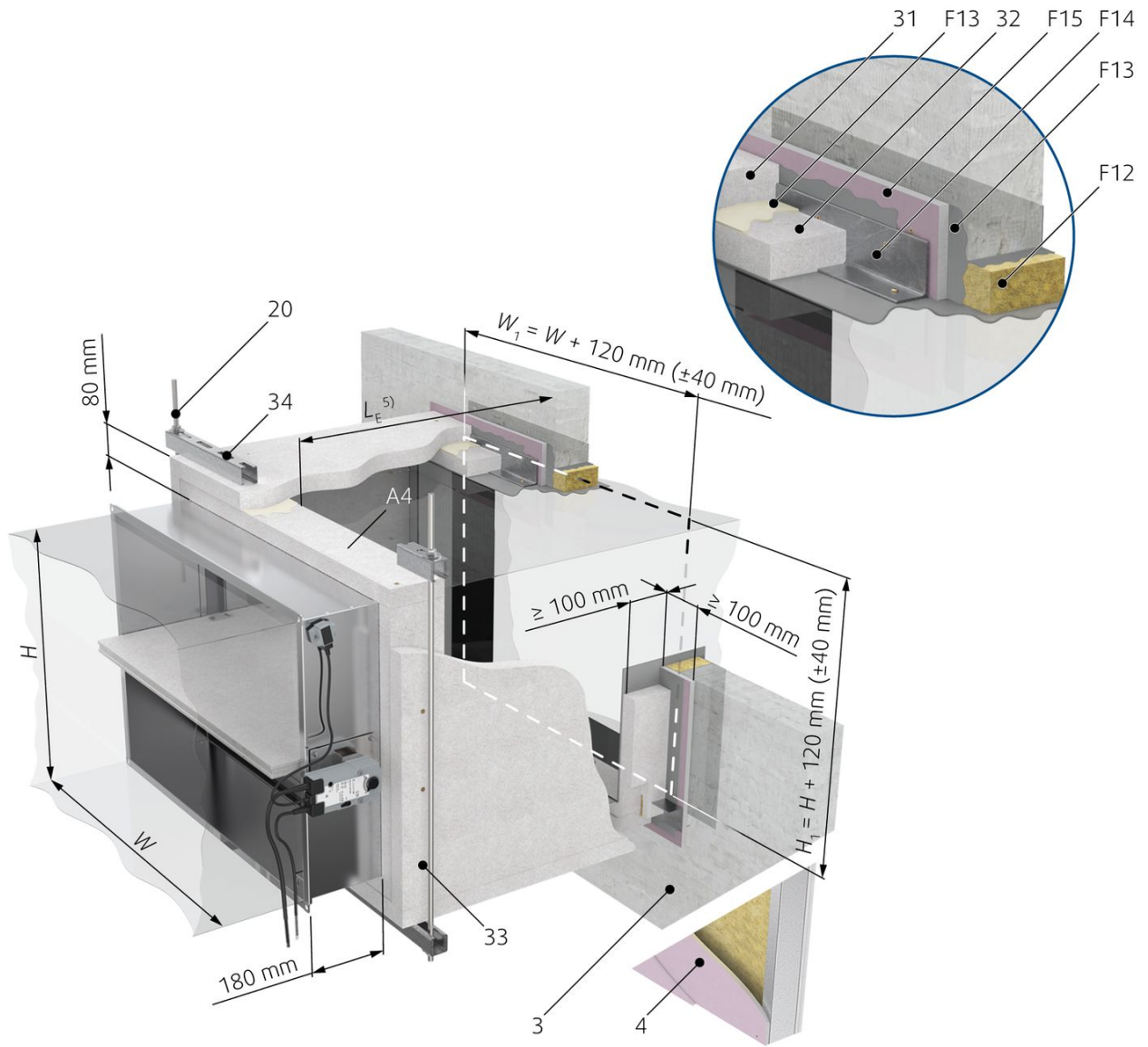

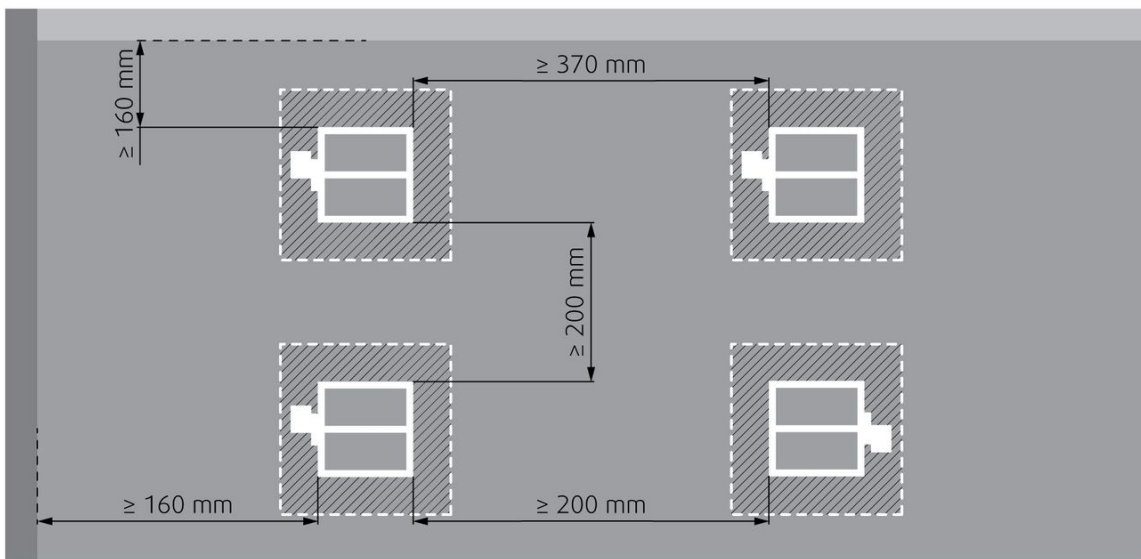
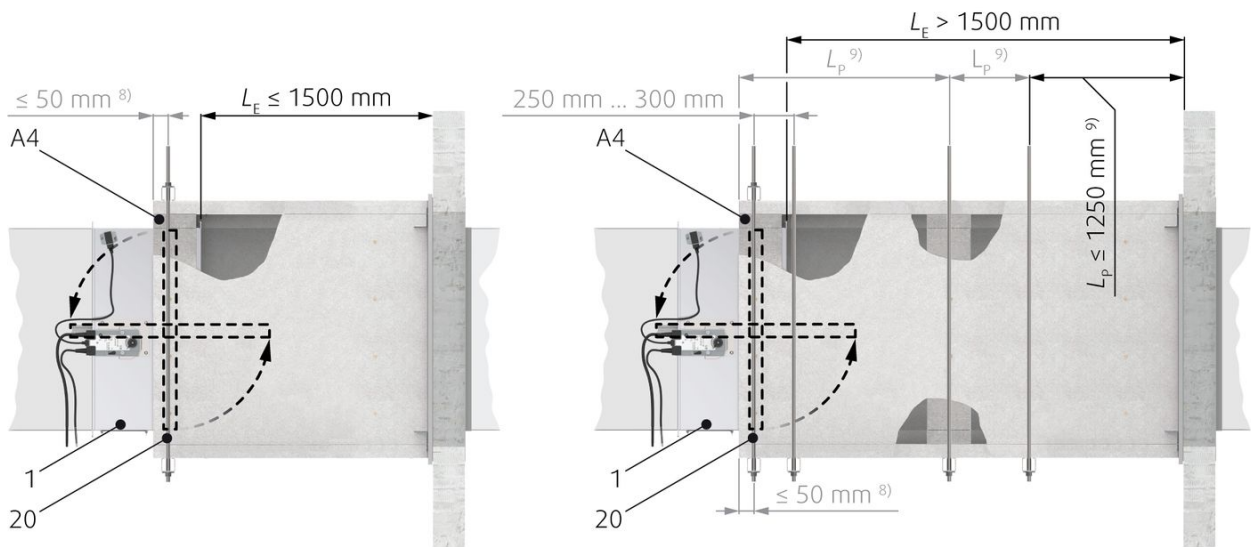
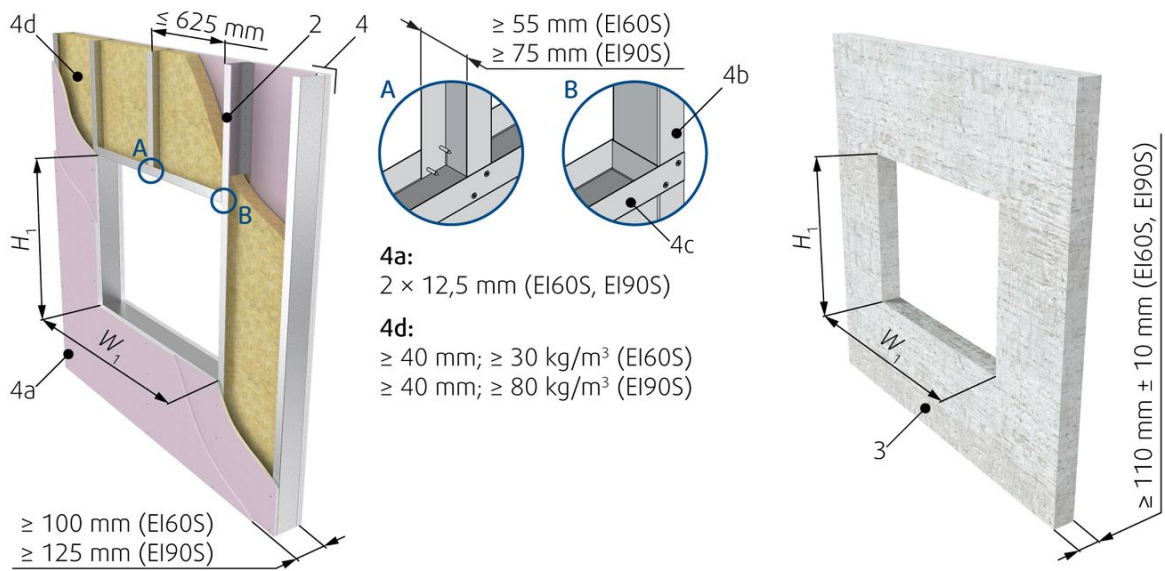

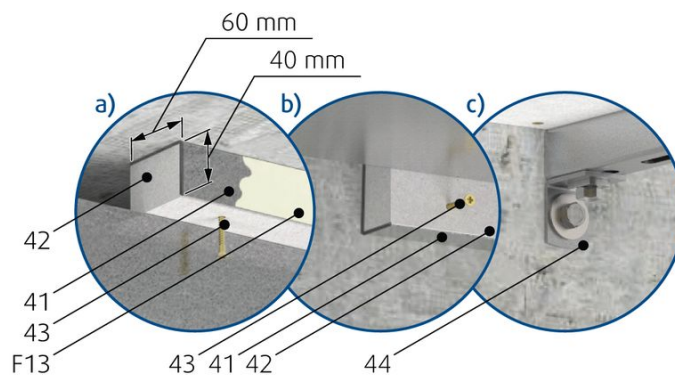
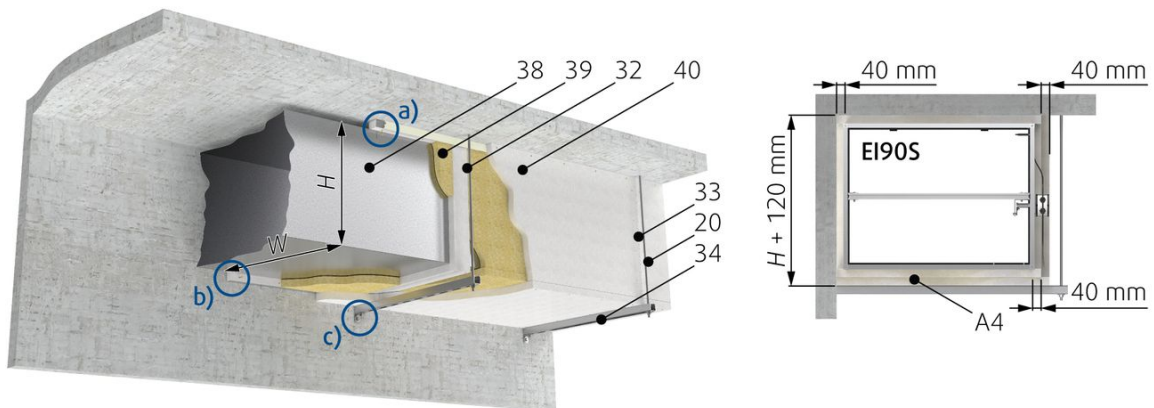
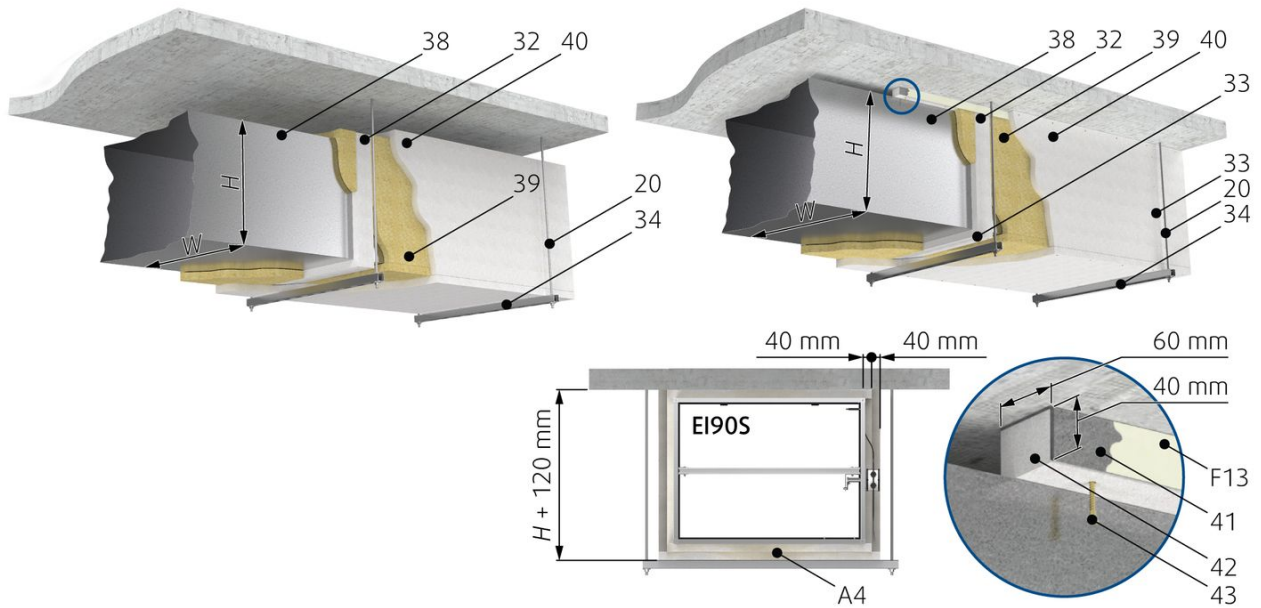

Legend

- F1** Screw $\geq 5,5$ DIN7981 or suitable wall plug and screw size 6.
- F12** Mineral wool segment thickness of 50 mm; min. 150 kg/m³ - in a wall
- F13** Fire resistive coating; Promat kleber K84/Promat
- F14** Steel L-profile 25 × 25 × 2 mm
- F15** Gypsum board thickness of 15 mm; width min. 100 mm
- A4** Installation kit IKOWS-FD-W×H (accessory)

- 1** Fire damper (actuator side)
- 3** Concrete/masonry/brick/cellular concrete wall or ceiling
- 4** Flexible (plasterboard) wall
- 4a** 2 layers of plasterboard fireproof plate type F, EN 520
- 4b** Vertical CW – profiles
- 4c** Horizontal CW – profiles
- 4d** Mineral wool; thickness/cubic density see picture.
- 20** Steel threaded rod M10
- 31** Calcium silicate board thickness of 40 mm; Promatect L500/Promat
- 32** Calcium silicate board; thickness 40 (20 + 20) × 100 mm; Promatect L500/Promat
- 33** Screw 5 × 80; DIN7997
- 34** U-profile (MQ41/HILTI)
- 38** Duct W × H that is eventually connected to the damper (damper is not depicted)
- 39** Mineral wool segment; thickness 40 mm/min. 40 kg/m³ (only EI60)
- 40** Calcium silicate board; thickness 20 mm (EI60) or 40 mm (EI90); Promatect L500/Promat
- 41** Steel L-profile 60 × 40 × 1 mm
- 42** Calcium silicate board; thickness 40 × 60 mm; Promatect L500/Promat
- 43** Screw with coak; span max. 250 mm
- 44** Corner connector; MQP-1/HILTI

Notes

- a)** - Flexible (plasterboard) wall
- b)** - Concrete/masonry/cellular concrete (rigid) wall
- v_e** - Vertical wall
- (5)** Rules for hanger placements and duct suspensions depend on the dampers distance from the supporting construction LE
- (6)** Rules for hanger placements LP and duct suspensions LS depend on the damper's distance from the supporting construction LE
- (7)** The distance P is the distance from the blade axis to the damper flange. The distance depends on the type of damper used.
- (8)** The hanger must be placed a max. of 50 mm from the edge of the IKOWS-FD.
- (9)** LP - The recommended length of the Promatect boards from the producer is 1250 mm; the legally allowed hanger span is 1500 mm.
- F2** Plaster/mortar/concrete filling - can serve as replacement of filling (F12). Using Plaster/mortar/concrete filling the coating (F13) for in the wall mineral wool is not needed.

5.4 ON & OUT of the wall installation, maximum EI60S

Using Promatect Boards

TIP: The duct-wall cavity filling (F12) and its coating (F13) can be also replaced by plaster/mortar/concrete (F2).

Damper Preparation before Installation: Attach all 4 parts of the IKOWS-FD accessory around the casing where the damper blade is situated, as shown in picture and apply a suitable fire-resistive coating (F13) to the contact surfaces of the boards and the damper. Fasten them together using the screws included in the IKOWS-FD package.

1. The supporting construction opening must be prepared as depicted. Opening surfaces must be even and cleaned off. The flexible wall opening must be reinforced as per the standards for plasterboard walls. The opening dimensions are driven by the nominal dimensions of the damper with added clearance. For rectangular dampers, the opening will have the dimensions of W1 and H1.
2. Insert the duct into the load-bearing structure along with the damper in such a way that the duct will stick out of the wall to the needed distance. Press the insulation around the duct (F12) and cut its edges to even it with the wall surface.
3. Paint the insulation surface in alignment with the wall with a suitable coat of paint (F13) up to 100 mm from the duct to cover the insulation and part of the wall. Or use filling (F2) as per WET installation.
4. Fit 4 boards (F15) of 100 mm in width around the duct and secure them using suitable screws (F1) to the wall; fasten an L-profile (F14) to the wall and the duct on the damper side; fasten 4 boards (F15) by joining them together in corners with screws.
5. Insert mineral wool segments (37) around the duct perimeter between the boards (35) and the IKOWS-FD accessory (A4). Cover the IKOWS-FD accessory (A4) and the boards (35) along the entire length with 20 mm thick boards (36); apply fire-resistive coating (F13) to all joints and fix the boards with screws (33).
6. Bind the damper in the blade location using a profile (34) at the top and bottom damper side, using threaded rods (20) and nuts. The threaded rods are to be at a distance of a max. of 50 mm from the side insulation surface.
7. If needed, uncover and clean the damper after installation.
8. Make sure the fixing screws are not interfering with the blade movement and check the damper's functionality.

Duct rules

The rules for hanger placement and duct suspension depend on the damper's distance from the supporting construction. The desired distance from the wall to the end of the duct connection with the damper divides the rules into two groups:





- Distance from 35 mm to max. 1500 mm.
- Distance greater than 1500 mm.

Installation Distances

For installation 5.4 ON & OUT, the minimum distance from the wall or ceiling to the damper body is 40 mm. For multiple crossings through a fire-resistive wall the minimum distance between two damper bodies is 200 mm. The distance 200 mm applies for distances between the damper and a nearby foreign object crossing the fire-resistive wall.

Installation in a Wall thinner than tested

Installation in a thinner wall is allowed under the condition that an additional layer/layers of fire protective board are fixed to the surface of the wall in order to achieve the same length of damper penetration seal as was tested. The minimum width of added boards around the damper is 200 mm. In addition, the alternative thinner wall should be classified in accordance with EN 13501-2:2007 + A1: 2009 for fire-resistance required for product application. For a protruding wall, the additional layers must be fixed on the steel supporting construction of the wall.

 <p>FDS-3G 100 × 100 1200 × 800 5.4 On, Out</p>	<p>FDS-3G 100 × 100 1200 × 800</p>	<p>EI 60 ($v_e - i \leftrightarrow o$) S</p>	<p>a) </p>	<p>b) </p>	
--	--	---	---	--	---

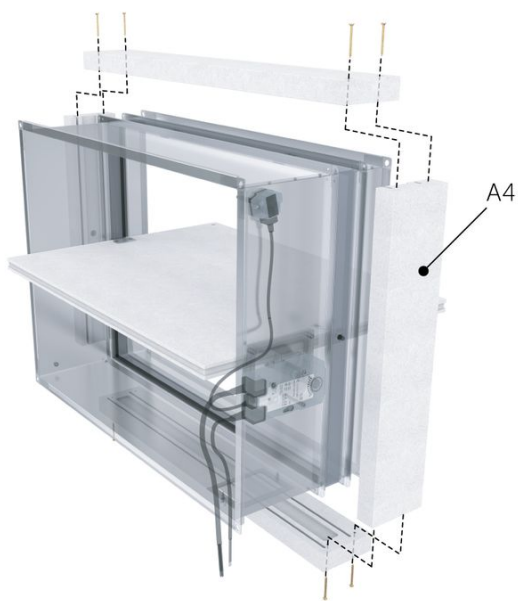
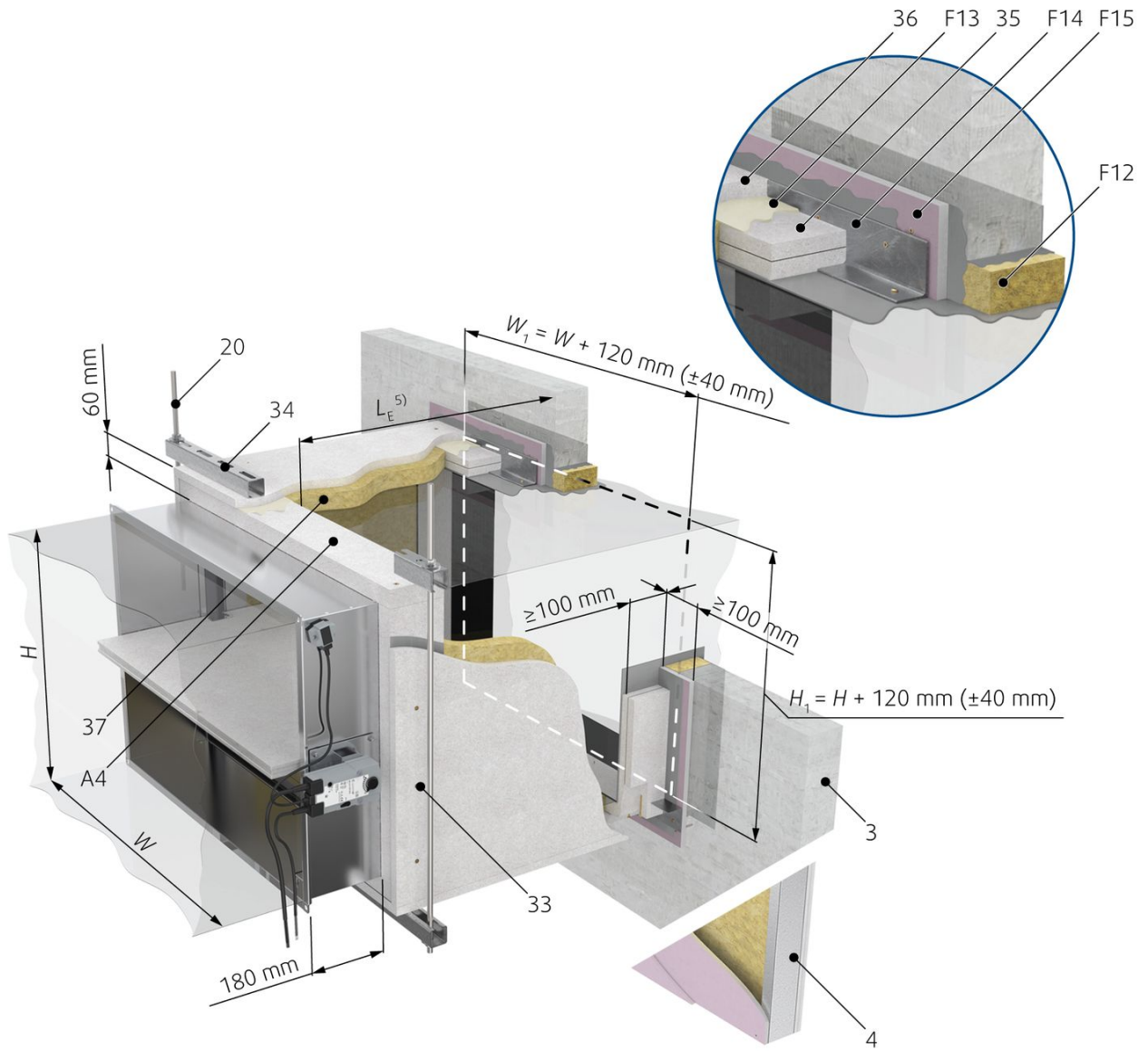

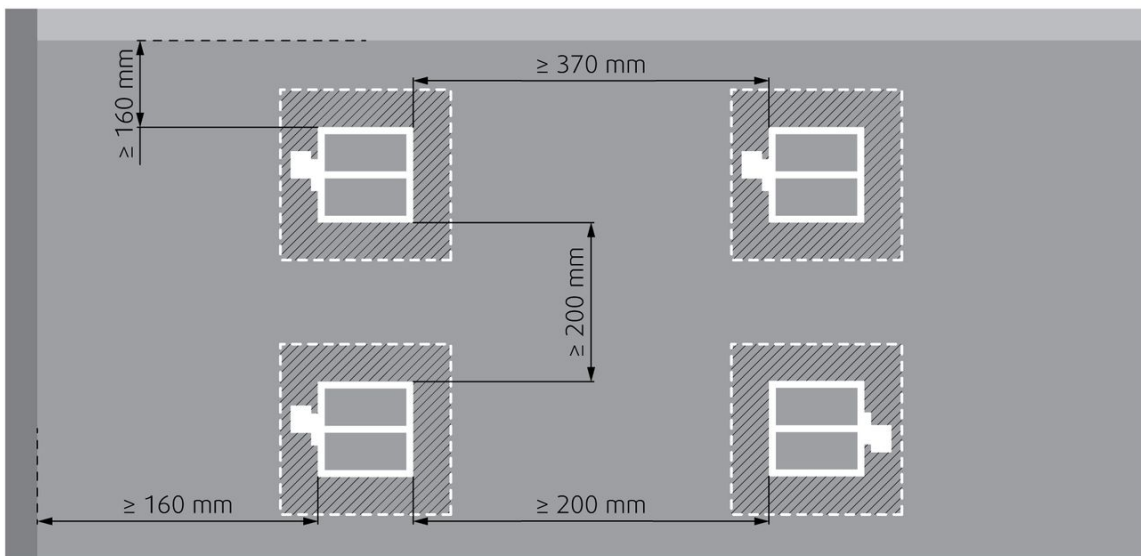
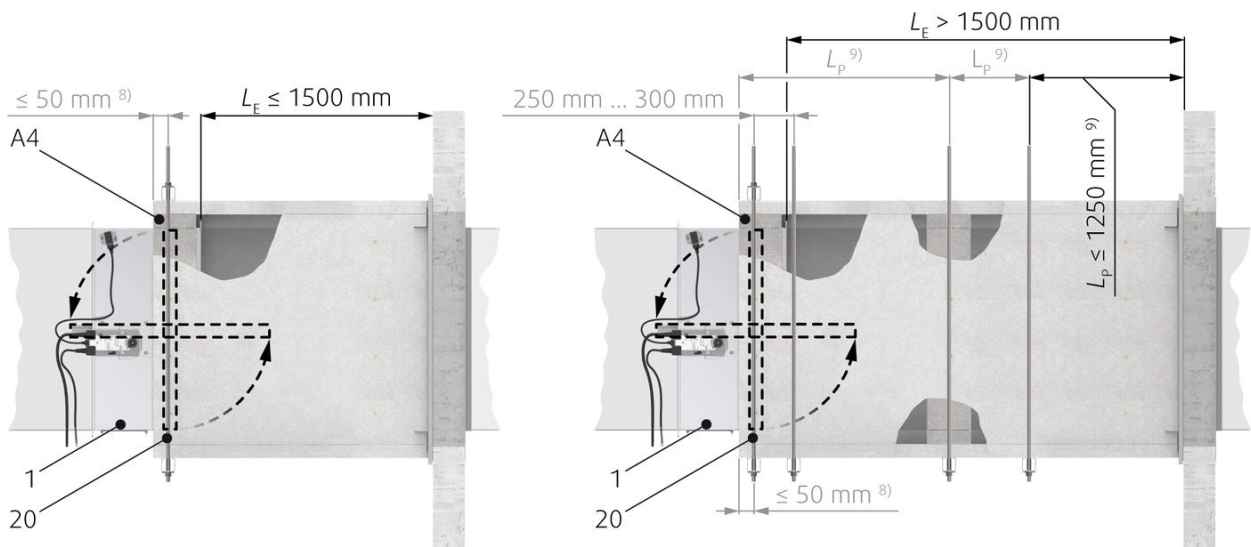
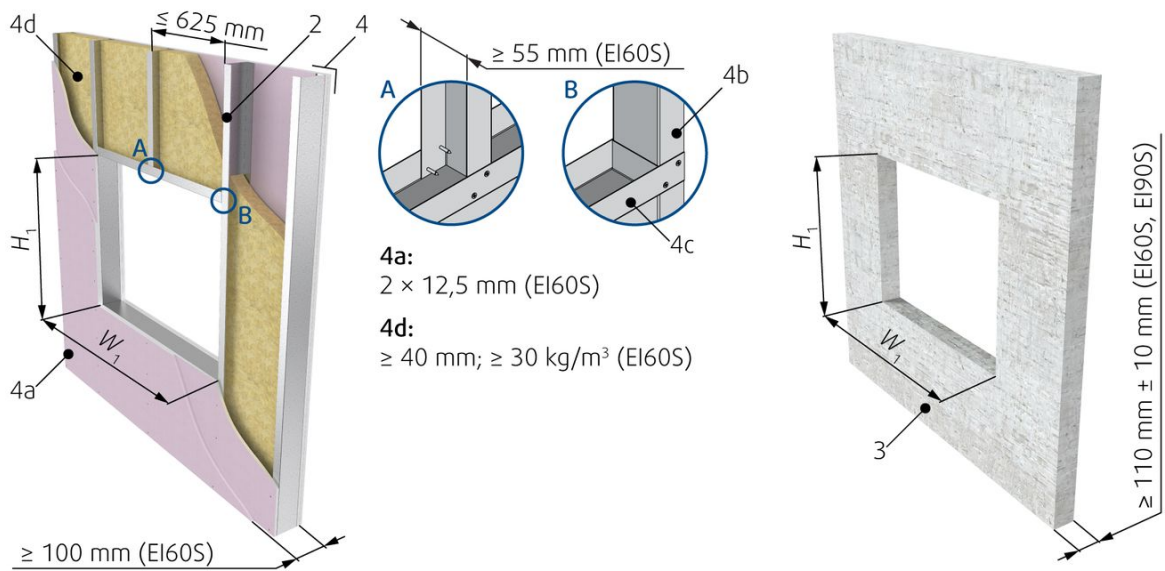

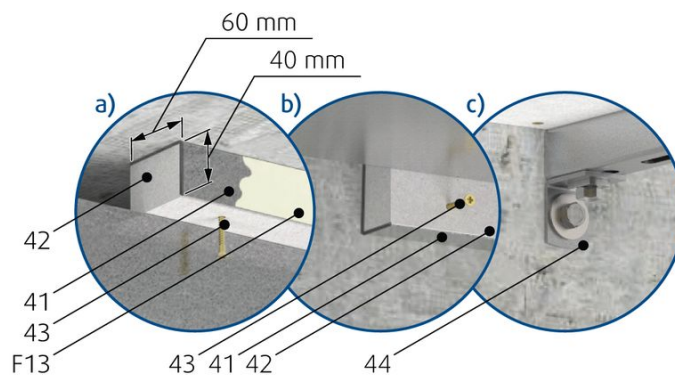
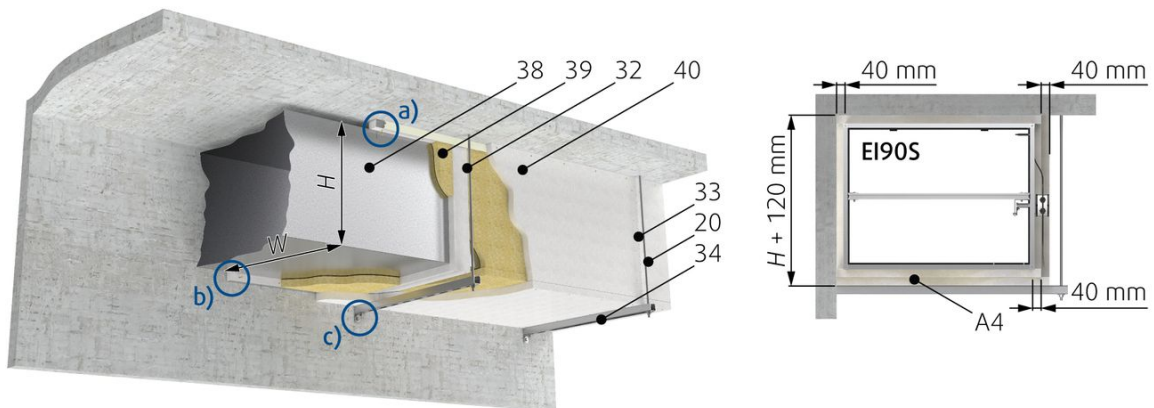
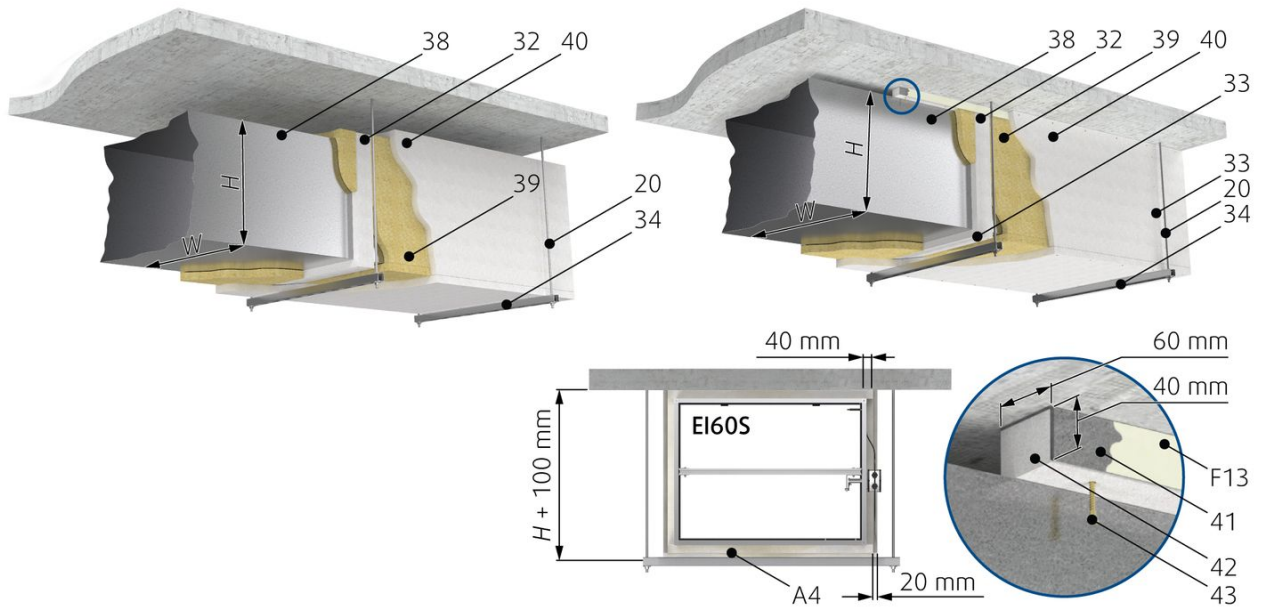

Legend

- F1** Screw $\geq 5,5$ DIN7981 or suitable wall plug and screw size 6.
- F12** Mineral wool segment thickness of 50 mm; min. 150 kg/m³ - in a wall
- F13** Fire resistive coating; Promat kleber K84/Promat
- F14** Steel L-profile 25 × 25 × 2 mm
- F15** Gypsum board thickness of 15 mm; width min. 100 mm
- A4** Installation kit IKOWS-FD-W×H (accessory)

- 1** Fire damper (actuator side)
- 3** Concrete/masonry/brick/cellular concrete wall or ceiling
- 4** Flexible (plasterboard) wall
- 4a** 2 layers of plasterboard fireproof plate type F, EN 520
- 4b** Vertical CW – profiles
- 4c** Horizontal CW – profiles
- 4d** Mineral wool; thickness/cubic density see picture.
- 20** Steel threaded rod M10
- 32** Calcium silicate board; thickness 40 (20 + 20) × 100 mm; Promatect L500/Promat
- 33** Screw 5 × 80; DIN7997
- 34** U-profile (MQ41/HILTI)
- 35** Calcium silicate board thickness of 20 mm; width min. 100 mm; 2 layers; Promatect L500/Promat
- 36** Calcium silicate board thickness of 20 mm; Promatect L500/Promat
- 37** Mineral wool segment thickness of 40 mm; min. 45 kg/m³
- 38** Duct W × H that is eventually connected to the damper (damper is not depicted)
- 39** Mineral wool segment; thickness 40 mm/min. 40 kg/m³ (only EI60)
- 40** Calcium silicate board; thickness 20 mm (EI60) or 40 mm (EI90); Promatect L500/Promat
- 41** Steel L-profile 60 × 40 × 1 mm
- 42** Calcium silicate board; thickness 40 × 60 mm; Promatect L500/Promat
- 43** Screw with coak; span max. 250 mm
- 44** Corner connector; MQP-1/HILTI



Notes

- a)** - Flexible (plasterboard) wall
- b)** - Concrete/masonry/cellular concrete (rigid) wall
- v_e** - Vertical wall
- (5)** Rules for hanger placements and duct suspensions depend on the dampers distance from the supporting construction LE
- (6)** Rules for hanger placements LP and duct suspensions LS depend on the damper's distance from the supporting construction LE
- (7)** The distance P is the distance from the blade axis to the damper flange. The distance depends on the type of damper used.
- (8)** The hanger must be placed a max. of 50 mm from the edge of the IKOWS-FD.
- (9)** LP - The recommended length of the Promatect boards from the producer is 1250 mm; the legally allowed hanger span is 1500 mm.
- F2** Plaster/mortar/concrete filling - can serve as replacement of filling (F12). Using Plaster/mortar/concrete filling the coating (F13) for in the wall installed mineral wool is not needed.

7 Multiple Damper Installation, EI90S

Installing a Set of FDS-EI90S Fire Dampers

1. For a damper installation, prepare a square opening with the dimensions W1 and H1, the opening surfaces must be even and cleaned off.
2. Determine the bottom level of the duct body crossing and insert L-profiles (F7) on both wall sides. While fixing with screws (F8), perform a level check. Fill in the acquired area with mineral wool (F5) in the bottom and sides of the opening. Before inserting into the opening, apply a fire-resistant layer/fire-resistive coating (F4) onto the contact surfaces of the wool.
3. Before placing the dampers onto the profiles, prepare a slot cut out from the filled mineral wool. This slot cut out will incorporate the protruding frame of the damper at the blade position. This slot cut must be performed in the wool around all dampers.
4. Paint the insulation with fire-resistive layer (F4), as well as the contact surfaces with the damper and insert the bottom damper FDS-1A.
5. Fix the bottom dampers through the L-profile using self-drilling screws (F8). with gaps of a max. of 200 mm.
6. Using fire-resistive coating (F4), glue mineral wool segments (F5) with a thickness of 80 mm to the FDS-1A damper sides' edging to the middle of the set. The dimensions of the mineral wool block need to correspond to the entire area between the FDS-1A and FDS-1B damper so that the area is completely filled. Apply a fire-resistant layer onto the external contact surfaces of the wool and the FDS-1A damper.
7. Place the second FDS-1B damper onto the L-profiles and press it against the first damper in such a way that the dampers will be touching each other with flanges on both sides, and fasten them with suitable terminals. Attach from the bottom through the L-profile using self-drilling screws (F8) with gaps of a max. of 200 mm. Secure the dampers between each other with sheet metal belts (45) on both sides with screws (8) across the entire flange contact surface. The maximum allowed gap between the screws is 200 mm.
8. On the top side of dampers FDS-1A and FDS-1B, forming a dividing line of the future second row FDS-2A and FDS-2B, apply fire-resistive coating and place mineral wool with a thickness of 80 mm (F5). Using sheet metal belt (45), create a backstop belt with a length of WL from one side of the installation and attach it with screws (F8). If it is necessary to enhance the stability of the FDS-2A damper, fix it provisionally into the side of the wall, until it is firmly embedded into the wall using an L-profile (F7).
9. Apply the same method used for the installation of FDS-2A also for the installation of the FDS-2B damper and face the mechanism to the opposite side.
10. Any empty space that has remained between the dampers and the wall needs to be filled with wool and fire-resistive coating. For this purpose, it is possible to dismount the mechanism from the dampers on which it is hindering.
11. Fix the top dampers using L-profiles (F7) into the wall using screws (F1) and the profile with the damper using self-drilling screws (F8) with maximum gaps of 200 mm.
12. All the L-profiles need to have consoles (F16) welded to them. Into a nominal dimension of the set WL = 1200 mm, one console in the middle and for the dimensions WL > 1200 mm two consoles into 1/3 and 2/3 of the L-profile's length and screw them against the wall using screws (F1).
13. Make sure all touching flanges are covered with sheet metal belts (45) and fixed with screws (F8). The maximum allowed gap between the screws is 200 mm.
14. Paint fire-resistive coating (F4) on the insulation filling and damper body around the opening and between the dampers. The minimal layer thickness is 2 mm. The width of the painted area is at least 100 mm.
15. Before the fire-resistive coating dries, remove the unwanted remnants of the coating.
16. If needed, uncover and clean the damper after installation and install the dismounted mechanisms.
17. Make sure the fixing screws are not interfering with the blade movement.
18. Check the damper functionality.

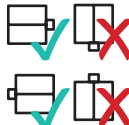
 <p>7 Multi</p>	<p>FDS-EI90S $W \leq 1600$ & $H \leq 1000$</p>	<p>EI 90 ($v_e - i \leftrightarrow o$) S</p>	<p>b) </p>	
--	---	---	---	--

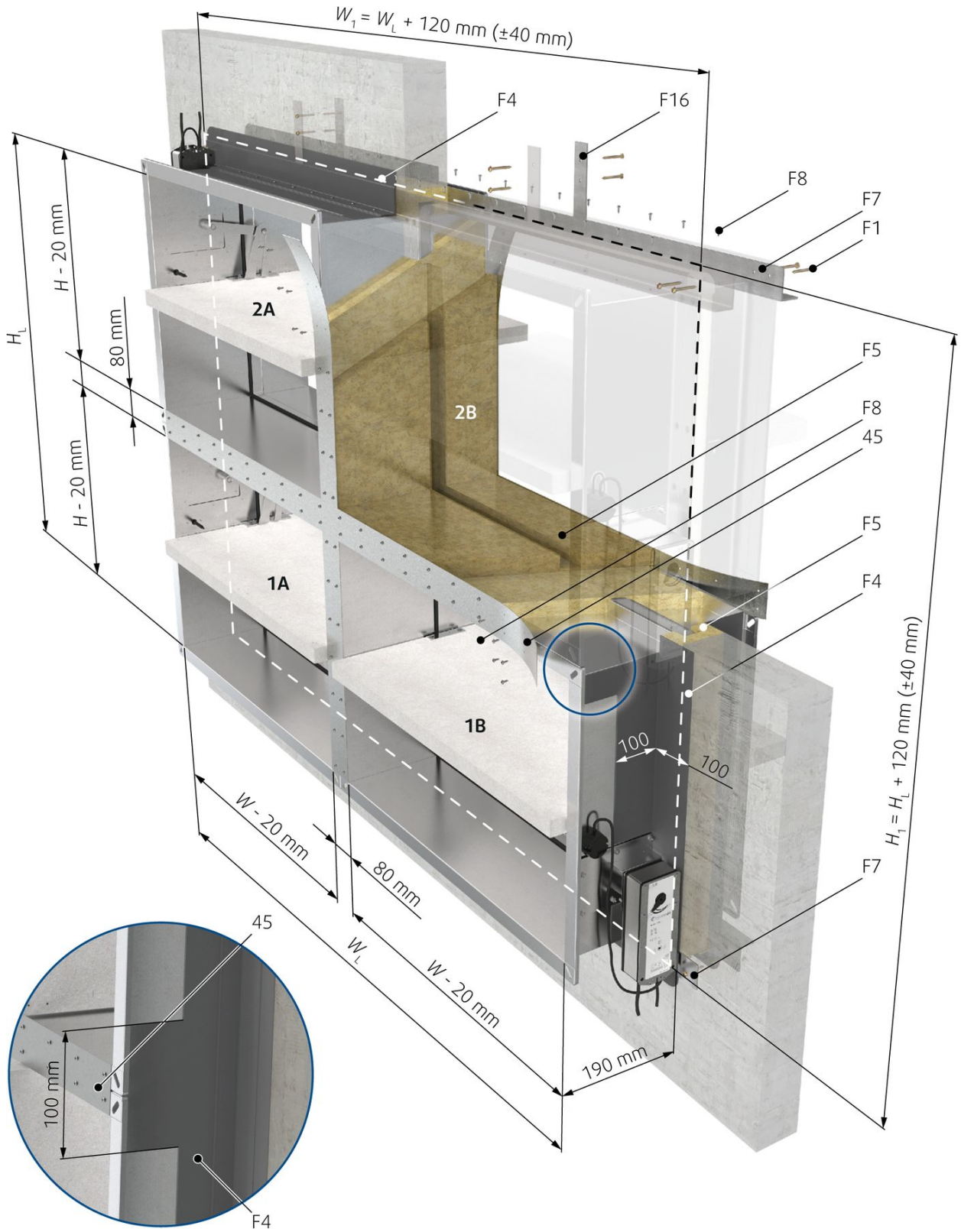

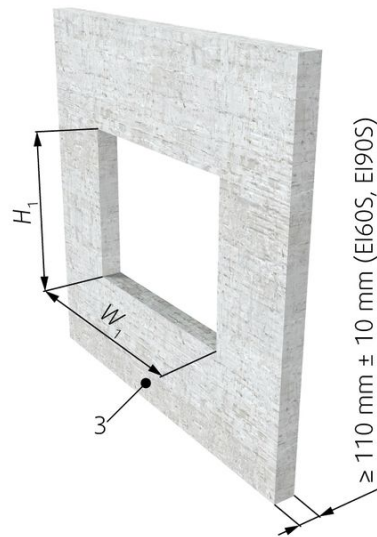

Legend

- F1** Screw $\geq 5,5$ DIN7981 or suitable wall plug and screw size 6.
- F4** Fire resistive coating, e.g. Promastop-CC/Promat
- F5** Mineral wool segment (min. 150 kg/m³)
- F7** L-profile 60 × 40 × 3 mm, length W + 300 mm or WL + 300 mm
- F8** Screw 3,9 × max. 13 DIN7504
- F16** Console 150 × 40 × 3 mm with two 6 mm openings
- 1** Fire damper (actuator side)
- 3** Concrete/masonry/brick/cellular concrete wall or ceiling
- 45** Sheet metal belt 80 × 0,9 mm

Notes

b) - Concrete/masonry/cellular concrete (rigid) wall

v_e - Vertical wall

F2 - Plaster/mortar/concrete filling - can serve as replacement of filling (F12). Using Plaster/mortar/concrete filling the coating (F13) for in the wall installed mineral wool is not needed.

Electrical Connections

T/PC/A		W (mm)																	
		100	150	200	250	300	315	350	355	400	450	500	550	560	600	630	650	700	710
H (mm)	100																		
	150																		
	175																		
	180																		
	200																		
	250																		
	300																		
	315																		
	350																		
	355																		
	400																		
	450																		
	500																		
	550																		
	560																		
	600																		
	630																		
	650																		
	700																		
	710																		
750																			
800																			
850																			
900																			
950																			
1000																			

B230T/6,5 VA/BFL230-T
 B24T/4 VA/BFL24-T
 B24T-W/4 VA/BFL24-T-ST
 BST0/11 VA/BFL24-T-ST + BKN230-24
 B24T-SR/6,5 VA/BFL24-T-SR

B230T/10 VA/ BFN230-T
 B24T/6 VA/BFN24-T
 B24T-W/6 VA/BFN24-T-ST
 BST0/11 VA/BFN24-T-ST + BKN230-24
 B24T-SR/8,5 VA/BFN24-T-SR

B230T/11 VA/BF230-T
 B24T/10 VA/BF24-T
 B24T-W/10 VA/BF24-T-ST
 BST0/11 VA/BF24-T-ST + BKN230-24
 B24T-SR-KR/9,5 VA/BF24-T-SR

T/PC/A		W (mm)																			
		100	150	200	250	300	315	350	355	400	450	500	550	560	600	630	650	700	710	750	800
H (mm)	100																				
	150																				
	175																				
	180																				
	200																				
	250																				
	300																				
	315																				
	350																				
	355																				
	400																				
	450																				
	500																				
	550																				
	560																				
	600																				
	630																				
	650																				
	700																				
	710																				
750																					
800																					
850																					
900																					
950																					
1000																					

G230T/9,5 VA/340TA-230-05...
 G24T/9 VA/340TA-024-05...
 G24T-W/9 VA/340TA-024-05...ST01
 GST0/11 VA/340TA-024-05...ST01 + fs-UFC24-2
 G24T-SR/7,5 VA/340CTA-024-05...

G230T/11,5 VA/360TA-230-12...
 G24T/7 VA/360TA-024-12...
 G24T-W/7 VA/360TA-024-12...ST01
 GST0/9 VA/360TA-024-12...ST01 + fs-UFC24-2
 G24T-SR/8 VA/360CTA-024-12...

T/PC/A		W (mm)																
		850	900	950	1000	1050	1100	1120	1150	1200	1250	1300	1350	1400	1450	1500	1550	1600
H (mm)	100																	
	150																	
	175																	
	180																	
	200																	
	250																	
	300																	
	315																	
	350																	
	355																	
	400																	
	450																	
	500																	
	550																	
	560																	
	600																	
	630																	
	650																	
	700																	
	710																	
750																		
800																		
850																		
900																		
950																		
1000																		

G230T/9,5 VA/340TA-230-05...
 G24T/9 VA/340TA-024-05...
 G24T-W/9 VA/340TA-024-05...ST01
 GST0/11 VA/340TA-024-05...ST01 + fs-UFC24-2
 G24T-SR/7,5 VA/340CTA-024-05...

G230T/11,5 VA/360TA-230-12...
 G24T/7 VA/360TA-024-12...
 G24T-W/7 VA/360TA-024-12...ST01
 GST0/9 VA/360TA-024-12...ST01 + fs-UFC24-2
 G24T-SR/8 VA/360CTA-024-12...

NOTE:

T/PC/A - Activation Type / Power Consumption / Actuator**Type of activation H0**

This type of activation mechanism does not have any electrical equipment.

Type of activation H2

IMPORTANT: Danger of electric shock!

Switch off the power supply before working on any electrical equipment.

Allow only qualified electricians to work on the electrical system.

Microswitch: Power Supply: AC 125/250 V or DC 12/24 V

Electric Parameters: 3A

NOTES:

- Supply via safety isolation transformer!

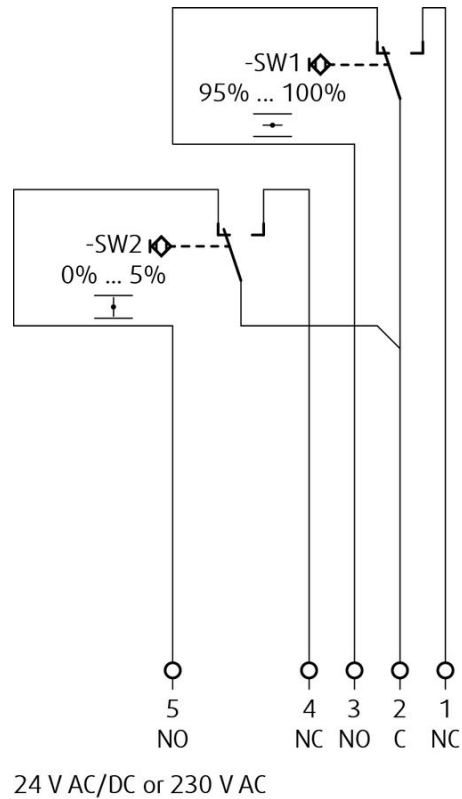

Legend

- 1 Grey cable colour
- 2 Orange cable colour
- 3 Pink cable colour
- 4 White cable colour
- 5 Red cable colour
- 6 Brown cable colour (Do not use for type of activation H2)
- X:7 Blue cable colour (Do not use for type of activation H2)

Type of activation H5-2

IMPORTANT: Danger of electric shock!

Switch off the power supply before working on any electrical equipment.

Allow only qualified electricians to work on the electrical system.

Microswitch:

Power Supply: AC 125/250 V or DC 12/24 V

Electric Parameters: 3A

Impulse Electromagnet:

Power Supply: AC (50/60 Hz)/DC 24 V

Electric Parameters: 50 VA, load factor 10% (maximum 30 seconds in operation)

NOTES:

- 50 VA = Nominal activation power, maximum permissible magnet load = 300 VA
- Supply via safety isolation transformer.
- Power consumption must be monitored!

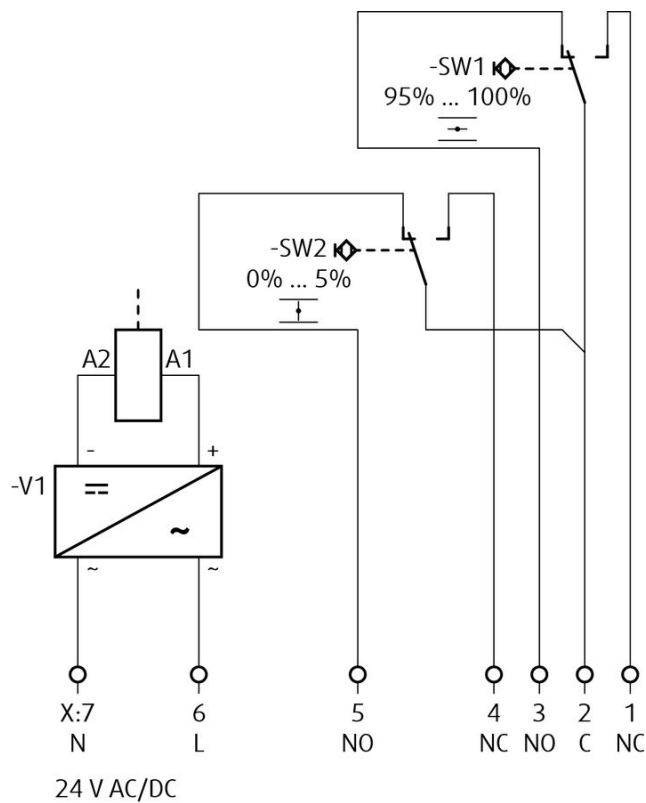

Legend

- 1 Grey cable colour
- 2 Orange cable colour
- 3 Pink cable colour
- 4 White cable colour
- 5 Red cable colour
- 6 Brown cable colour
- X:7 Blue cable colour

Type of activation H6-2

IMPORTANT: Danger of electric shock!

Switch off the power supply before working on any electrical equipment.

Allow only qualified electricians to work on the electrical system.

Microswitch:

Power Supply: AC 125/250 V or DC 12/24 V

Electric Parameters: 3A

Impulse Electromagnet:

Power Supply: AC 230 V, 50/60 Hz

Electric Parameters: 50 VA, load factor 10% (maximum 30 seconds in operation)

NOTES:

- 50 VA = Nominal activation power, maximum permissible magnet load = 300 VA
- Caution! Main power supply voltage!
- A device that disconnects the pole conductors (minimum contact gap 3 mm) is required for isolation from the power supply.
- Power consumption must be monitored!

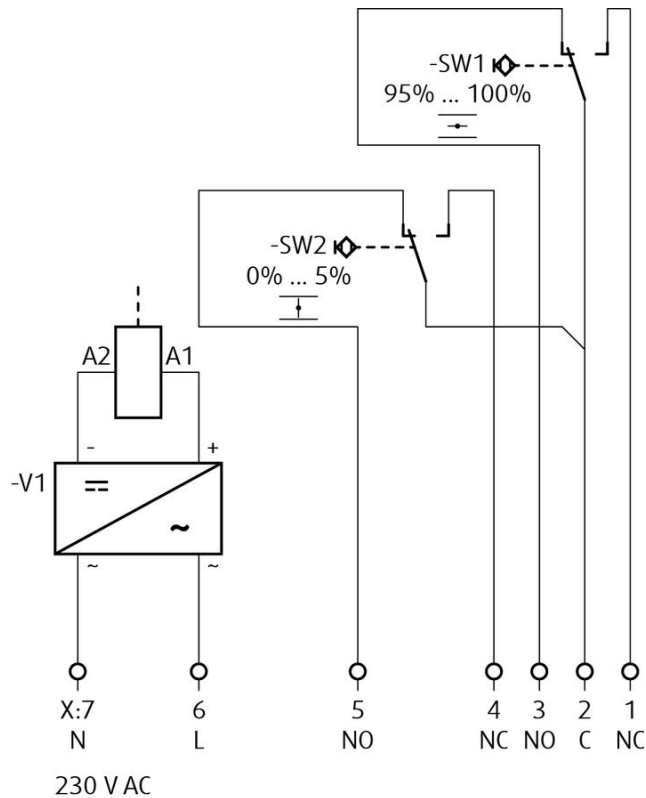

Legend

- 1 Grey cable colour
- 2 Orange cable colour
- 3 Pink cable colour
- 4 White cable colour
- 5 Red cable colour
- 6 Brown cable colour
- X:7 Blue cable colour

Type of activation B230T

IMPORTANT: Danger of electric shock!

Switch off the power supply before working on any electrical equipment.

Allow only qualified electricians to work on the electrical system.

Actuator power supply: AC 230 V, 50/60 Hz

NOTES:

- Caution! Main power supply voltage!
- A device that disconnects the pole conductors (minimum contact gap 3 mm) is required for isolation from the power supply.
- Parallel connection of several actuators possible.
- Power consumption must be monitored!

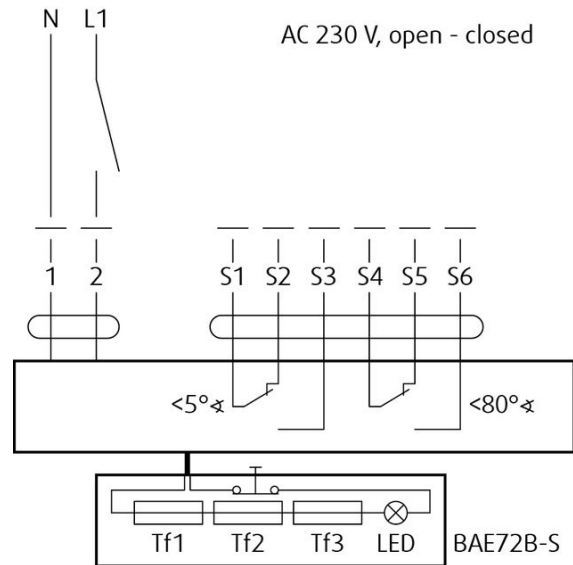

Legend

- 1** Blue cable colour
- 2** Brown cable colour
- S1** Violet cable colour
- S2** Red cable colour
- S3** White cable colour
- S4** Orange cable colour
- S5** Pink cable colour
- S6** Grey cable colour
- Tf** Thermal fuse

Type of activation G230T

IMPORTANT: Danger of electric shock!

Switch off the power supply before working on any electrical equipment.

Allow only qualified electricians to work on the electrical system.

Actuator power supply: AC 230 V, 50/60 Hz

NOTES:

- Caution! Main power supply voltage!
- A device that disconnects the pole conductors (minimum contact gap 3 mm) is required for isolation from the power supply.
- Parallel connection of several actuators possible.
- Power consumption must be monitored!

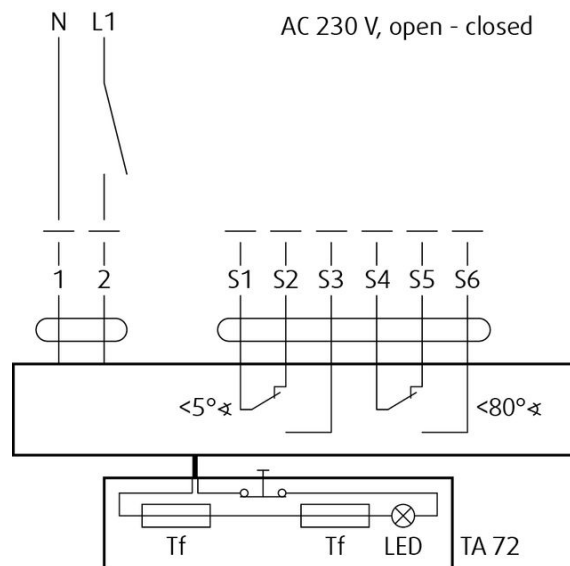

Legend

- 1** Blue cable colour
- 2** Brown cable colour
- S1** Violet cable colour
- S2** Red cable colour
- S3** White cable colour
- S4** Orange cable colour
- S5** Pink cable colour
- S6** Grey cable colour
- Tf** Thermal fuse

Type of activation B24T

IMPORTANT: Danger of electric shock!

Switch off the power supply before working on any electrical equipment.

Allow only qualified electricians to work on the electrical system.

Actuator power supply: AC (50/60 Hz)/DC 24 V

NOTES:

- Supply via safety isolation transformer.
- Parallel connection of several actuators possible.
- Power consumption must be monitored!

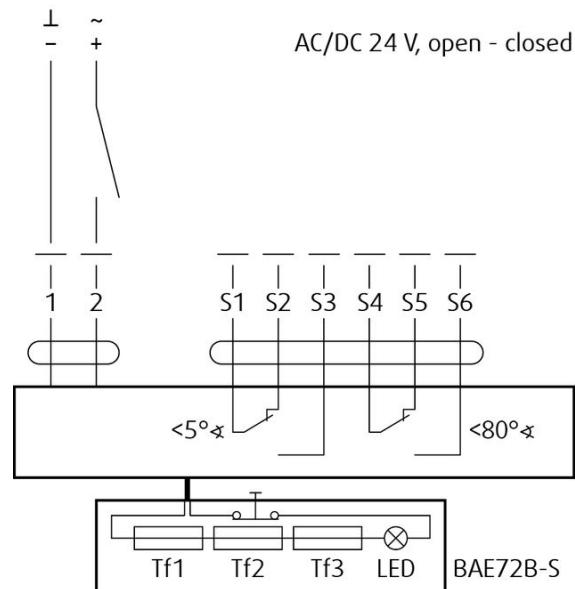

Legend

- 1** Blue cable colour (black for BF24-T)
- 2** Red cable colour (white for BF24-T)
- S1** Violet cable colour (white for BF24-T)
- S2** Red cable colour (white for BF24-T)
- S3** White cable colour (white for BF24-T)
- S4** Orange cable colour (white for BF24-T)
- S5** Pink cable colour (white for BF24-T)
- S6** Grey cable colour (white for BF24-T)
- Tf** Thermal fuse

Type of activation G24T

IMPORTANT: Danger of electric shock!

Switch off the power supply before working on any electrical equipment.

Allow only qualified electricians to work on the electrical system.

Actuator power supply: AC (50/60 Hz)/DC 24 V

NOTES:

- Supply via safety isolation transformer.
- Parallel connection of several actuators possible.
- Power consumption must be monitored!

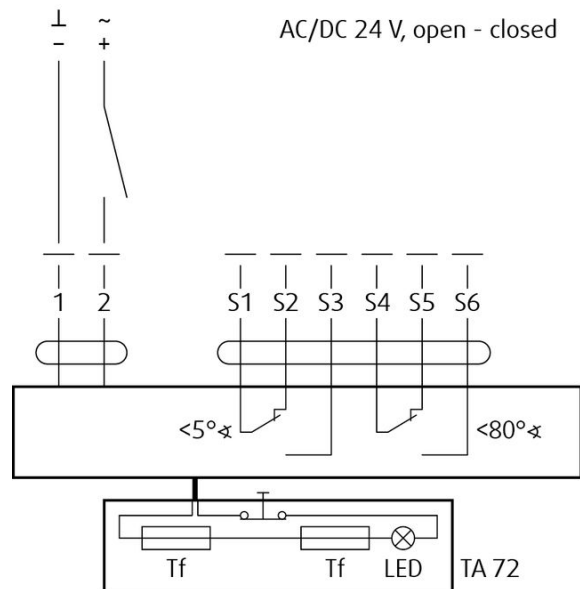

Legend

- 1** Black cable colour
- 2** Red cable colour
- S1** Violet cable colour
- S2** Red cable colour
- S3** White cable colour
- S4** Orange cable colour
- S5** Pink cable colour
- S6** Grey cable colour
- Tf** Thermal fuse

Type of activation B24T-W

IMPORTANT: Danger of electric shock!

Switch off the power supply before working on any electrical equipment.

Allow only qualified electricians to work on the electrical system.

This type of activation is with provided cable connectors for the supply and communication unit (communication unit not part of the mechanism).

Actuator power supply: AC (50/60 Hz)/DC 24 V

NOTES:

- Supply via safety isolation transformer.
- Parallel connection of several actuators possible.
- Power consumption must be monitored!

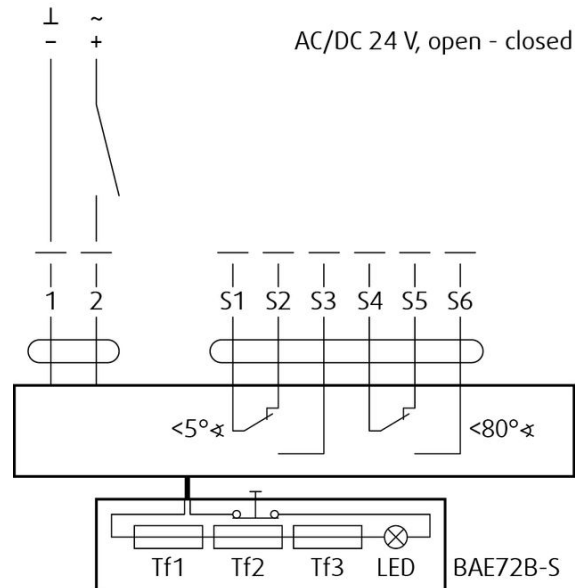

Legend

- 1** Blue cable colour (black for BF24-T) in connector 1
- 2** Brown cable colour (white for BF24-T) in connector 1
- S1** Violet cable colour (white for BF24-T) in connector 2
- S2** Red cable colour (white for BF24-T) in connector 2
- S3** White cable colour (white for BF24-T) in connector 2
- S4** Orange cable colour (white for BF24-T) in connector 2
- S5** Pink cable colour (white for BF24-T) in connector 2
- S6** Grey cable colour (white for BF24-T) in connector 2
- Tf** Thermal fuse

Type of activation G24T-W

IMPORTANT: Danger of electric shock!

Switch off the power supply before working on any electrical equipment.

Allow only qualified electricians to work on the electrical system.

This type of activation is with provided cable connectors for the supply and communication unit (communication unit not part of the mechanism).

NOTES:

- Supply via safety isolation transformer.
- Parallel connection of several actuators possible.
- Power consumption must be monitored!

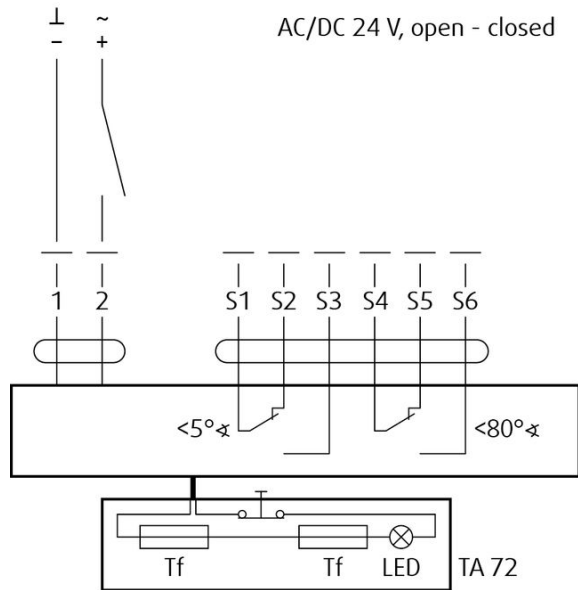

Legend

- 1** Black cable colour (black for BF24-T) in connector 1
- 2** Red cable colour (white for BF24-T) in connector 1
- S1** Violet cable colour (white for BF24-T) in connector 2
- S2** Red cable colour (white for BF24-T) in connector 2
- S3** White cable colour (white for BF24-T) in connector 2
- S4** Orange cable colour (white for BF24-T) in connector 2
- S5** Pink cable colour (white for BF24-T) in connector 2
- S6** Grey cable colour (white for BF24-T) in connector 2
- Tf** Thermal fuse

Type of activation BSTO

IMPORTANT: Risk of electric shock!

Switch off the power supply before working on any electrical equipment.

Only qualified electricians are allowed to work on the electrical system.

This type of activation is with a Belimo supply and communication unit BKN230-24 (other communication units on demand).

Actuator power supply: AC (50/60 Hz)/DC 24 V

NOTES:

- Connection scheme for standardly fitted BKN230-24.
- Power consumption must be observed.

LEDs status indication of actuator (BSTO)

LED colour | LED state | Status

Yellow | ON | Damper open

Yellow | Blinks | Damper is opening

Green | ON | Damper closed

Green | Blinks | Damper is closing

Yellow or green | Blinks at double frequency | Error

Yellow and green | OFF | Power failure

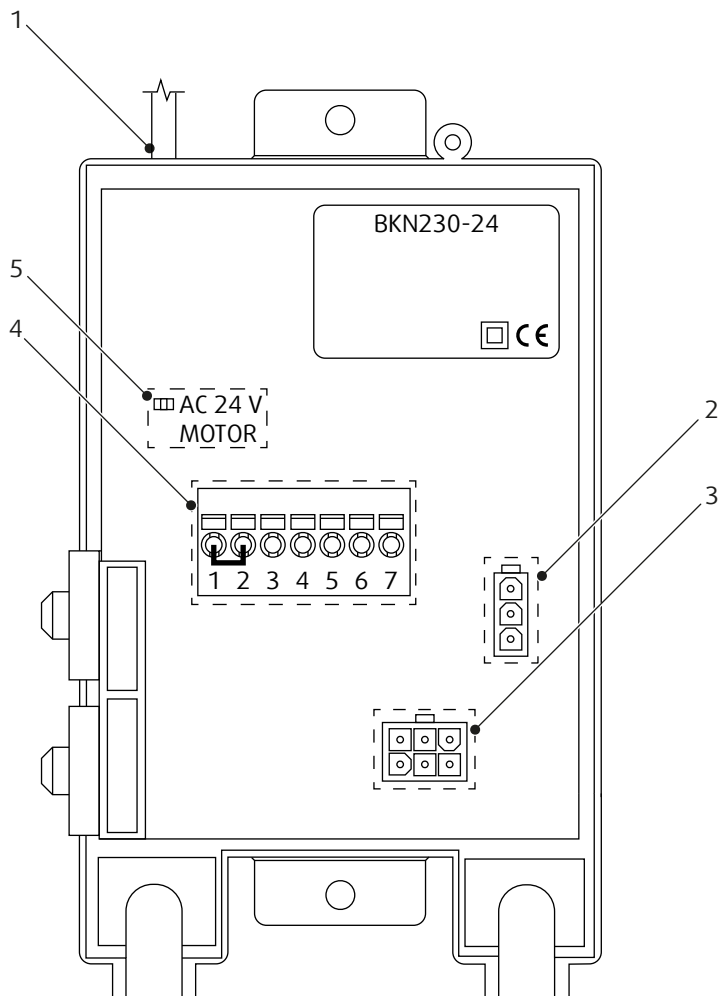

Legend

1 - Power supply: cable and plug, AC 230 V

2 - 3-pin connector: damper actuator (DC 24 V)

3 - 6-pin connector: damper actuator (position limit switches)

4 - Connecting terminals:

- 1 – 2 Jumper factory-fitted. Can be removed if necessary to be replaced by a thermoelectric trip (the safety function will be triggered if terminals 1 and 2 are not linked).
- 3 – 4 Use Jumper only for commissioning purposes and without BKS24-.. !
- 5 -
- 6 "a" connection to BKS24...
- 7 "b" connection to BKS24...

5 - LED indication - Actuator power

Type of activation GST0

IMPORTANT: Risk of electric shock!

Switch off the power supply before working on any electrical equipment.

Only qualified electricians are allowed to work on the electrical system.

This type of activation is with a Gruner supply and communication unit fs-UFC24-2 (other communication units on demand).

Actuator power supply: AC (50/60 Hz)/DC 24 V

NOTES:

- The actuator and the control module are factory wired.
- Individual control of 2 fire dampers
- Bus protocols (RS-485): BACnet MS/TP and Modbus RTU
- Automatic baud rate detection with BACnet
- Bus monitoring function

LEDs status indication (GST0)

LED color and type | LED state | Status

Yellow (Closed) | ON | Damper closed

Green (Open) | ON | Damper open

Yellow and green | Blinks in parallel | Damper is moving

Yellow and green | Alternately blinks - interval 0.5 sec | Actuator did not reach the end switch position within set time

Yellow and green | Alternately blinks - interval 3 sec | Alarm active at damper: bus command = actuator open, actuator = in closed position

Power green | OFF | Power failure

Power green | ON | Power is connected

Yellow Rx | Blinks | Receive data

Green Tx | Blinks | Transmit data

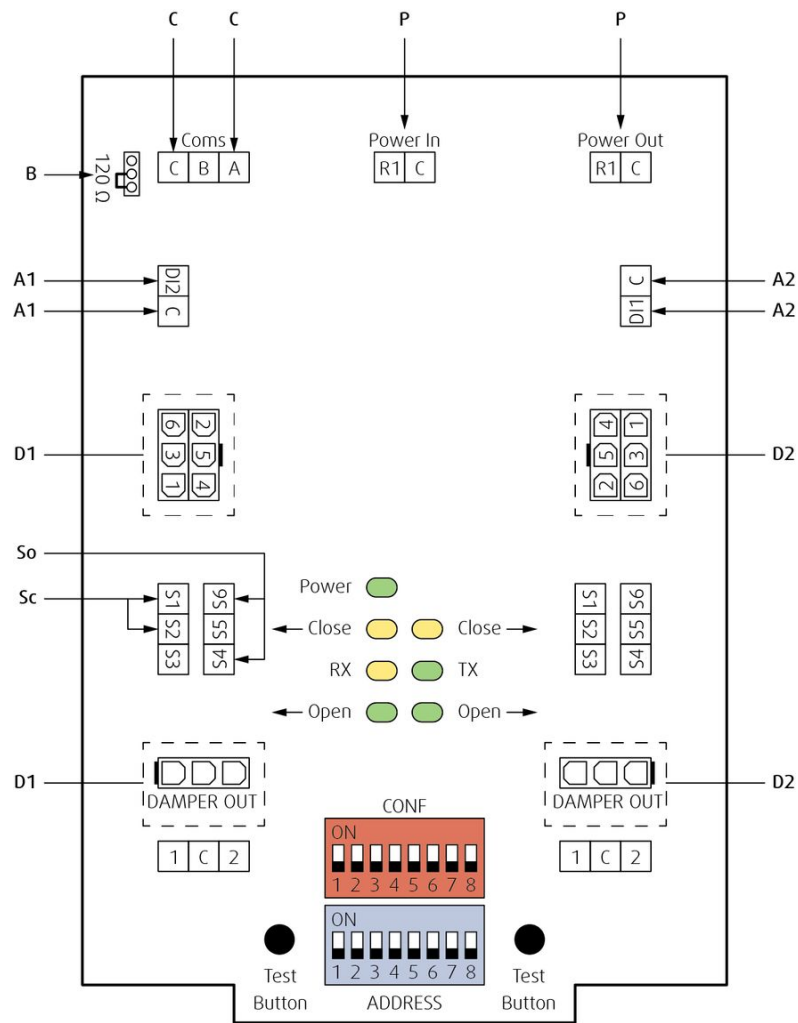

Legend

A1, A2 Analog Application; Digital input for manual override can be selected via bus as „Normally Open“ (= standard open) or „Normally Closed“ (= standard closed) Default: „Normally Open“

B Position of line termination 120 ohm if FS-UFC24-2 is last Modbus or BACnet device in line

C RS-485 Coms; Modbus RTU or BACnet MS/TP dip switch selectable

D1, D2 Damper 1, Damper 2; Fire or smoke extraction application

P Main power 24 V AC/DC; Daisy chain from and to other FS-UFC24-2

So Contact open

Sc Contact closed

Type of activation BST1

IMPORTANT: Danger of electric shock! Parallel circuits, i.e. a smoke detector on multiple slave devices are not allowed!

Switch off the power supply before working on any electrical equipment.

Allow only qualified electricians to work on the electrical system.

Actuator power supply via fitted communication unit: DC 24 V

NOTES:

- Left: Connection scheme for fitted communication and supply unit BC24-G2 (THC).
- Right: Example connection scheme for smoke detector ORS 142 K from Hekatron - not part of the delivery.

LEDs status indication (BST1)

LED colour | LED state | Status

Green | ON | Damper open

Green | Blinks | Damper is opening

Yellow | ON | Damper closed

Yellow | Blinks | Damper is closing

White | Blinks | SLC-communication ok – control command „close damper“

White | Flashes | SLC-communication ok – control command „open damper“

Red | ON | Safety element triggered (at X4)

Red | Blinks | self-test active; error: communication loss; error: actuator not connected; error: thermoelectric tripping device of actuator triggered; runtime monitoring error; mechanical error triggered

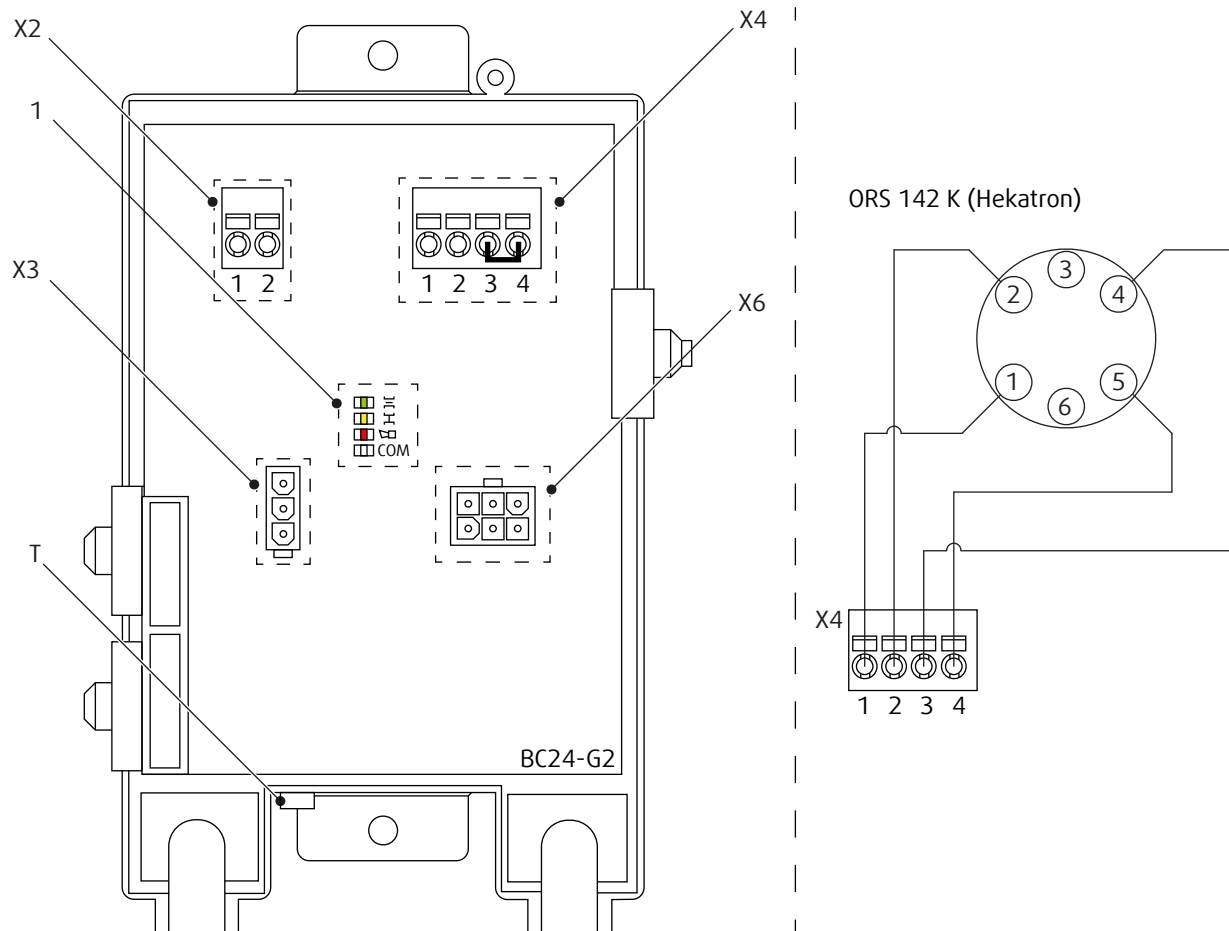

Legend

1 - LEDs for status indication

T - Test button: This allows the simple function test on site of the damper. The button operation causes an error message at the control device which must be reset.

X2 - 2-pin spring terminal: 1/2 - connection for SLC two-wire line, wires interchangeable. Maximum cable lengths can be calculated with the SLC Planning Tool. Rule of thumb: 300m@1.5 mm²

X3 - 3-pin connector: damper actuator (DC 24 V)

X4 - 4-pin spring terminal: Connection for smoke detector

- 1- (+) DC 24 V / max. 30 mA

- 2- GND

- 3- IN1 (external relay contact 1)

- 4- IN2 (external relay contact 2)

X6 - 6-pin connector: damper actuator (position limit switches)

Type of activation BST2

IMPORTANT: Danger of electric shock!

Switch off the power supply before working on any electrical equipment.

Allow only qualified electricians to work on the electrical system.

Actuator power supply via fitted communication unit: DC 24 V

NOTES:

- Depiction of parts for fitted communication and supply unit BKN230-24-MOD (Modbus/BACnet).

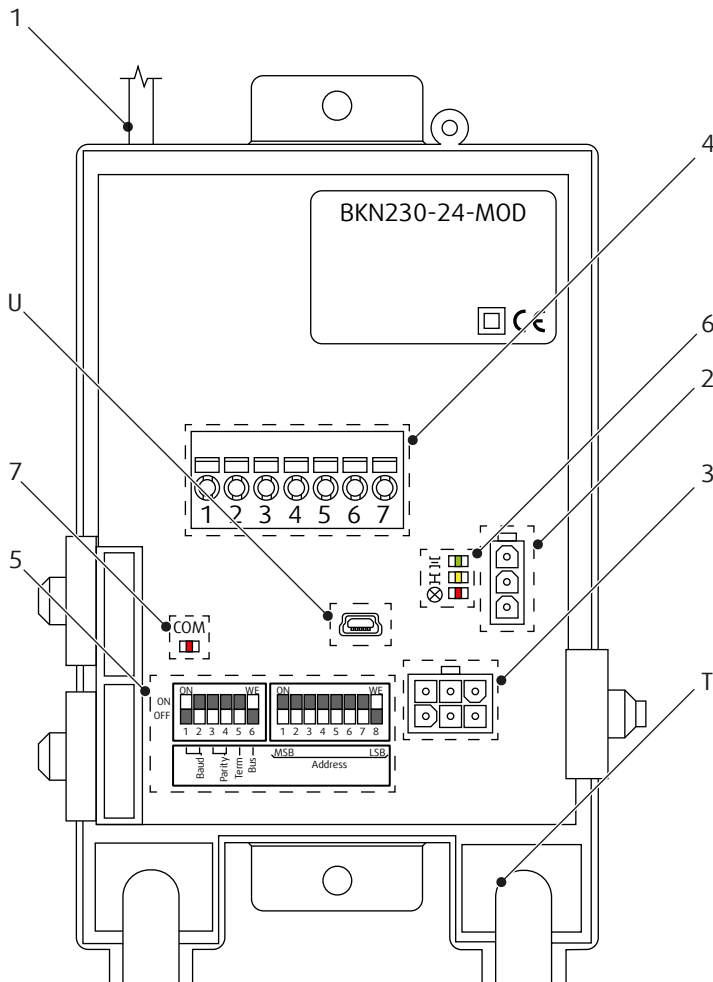

Legend

U - USB mini socket: BKN-MOD-BAC Update Tool

T - Test button: Test run / fault acknowledgement. Press the button for longer than one second to trigger the start of test run or to trigger a reset of present error message.

1 - Power supply: cable and plug, AC 230 V

2 - 3-pin connector: damper actuator (DC 24 V)

3 - 6-pin connector: damper actuator (position limit switches)

4 - 7-pin spring terminal:

- 1 External smoke detector, +24 V, max. 50 mA
- 2 External smoke detector, control input
- 3 GND
- 4 BKN Direct Control, override control input
- 5 Modbus GND
- 6 Modbus D+
- 7 Modbus D-

5 - Parametrization: DIL switch

- A1: Baud rate
- A2: Parity
- A3: Termination (on with 150 Ω)
- A4: Bus: BACnet (ON) or Modbus (OFF)
- B: Modbus address

6 - LEDs status indication of actuator**LED colour | LED state | Status**

Green | ON | Damper open

Green | Blinks | Damper is opening

Yellow | ON | Damper closed

Yellow | Blinks | Damper is closing

Red | Blinks | Internal device fault (BKN230-24-MOD)

Red | Blinks | External fault: smoke detector triggered; nominal position not reached

Red | Flashes | External fault: If an error is stored (i.e. no longer pending, but not yet acknowledged), then this is displayed on the device by a periodic flash of the red LED.

A1	1	2
9'600	OFF	OFF
19'200	OFF	ON
38'400	ON	OFF
76'800	ON	ON

A2	3	4
1-8-N-1	OFF	OFF

A3	5
150 Ω	ON
OFF	OFF

A4	6
BACnet	ON
Modbus	OFF

B	1	2	3	4	5	6	7	8
0	-	OFF	OFF	OFF	OFF	OFF	OFF	OFF
1	-	OFF	OFF	OFF	OFF	OFF	OFF	ON
2	-	OFF	OFF	OFF	OFF	OFF	ON	OFF
...	-	-	-	-	-	-	-	-
127	-	ON	ON	ON	ON	ON	ON	ON

7 - LED signalization of communication unit (BKN230-24-MOD)**LED colour | LED state | Status****Command OPEN / limit position not reached:**

Green | ON | -

Yellow | ON | Damper closed

Yellow | OFF | Damper blade is between close and open

Yellow | Flickering | BACnet/Modbus communication is illuminated during RX and TX

Red | Blinks | Error message after 180 seconds

Command CLOSE / limit position not reached:

Green | ON | Damper open

Green | OFF | Damper blade is between open and close

Yellow | Blinks | -

Yellow | Flickering | BACnet/Modbus communication is illuminated during RX and TX

Red | Blinks | Error message after 60 seconds

Type of activation BST3

IMPORTANT: Danger of electric shock!

Switch off the power supply before working on any electrical equipment.

Allow only qualified electricians to work on the electrical system.

Actuator power supply via fitted communication unit: DC 24 V

NOTES:

- Depiction of parts for fitted communication and supply unit BKN230-24-C-MP (SBS/MP).
- The unit can communicate either with the BKS24...-1B, ...-9A control modules via an analogue 2-wire system or digitally via a 2-wire connection to a BELIMO MP-Bus system.

LEDs status indication of actuator

LED colour | LED state | Status Green | ON | Damper open

Green | Blinks | Damper is opening

Yellow | ON | Damper closed

Yellow | Blinks | Damper is closing

Red | ON | Internal device fault (BKN230-24-C-MP)

Red | Blinks | External fault: thermoelectrical device (BAT...) triggered; smoke detector triggered

Red | Blinks briefly | MP-Bus communication active (i.e. MP commands are being received)

LED signalization of communication unit (BKN230-24-C-MP)

LED colour | LED state

Command OPEN / limit position not reached:

Red | Blinks

Green | OFF

Yellow | Blinks

Yellow | Signaling after 150 seconds

Command CLOSE / limit position not reached:

Red | Blinks

Green | Blinks

Yellow | OFF

Yellow | Signaling after 150 seconds

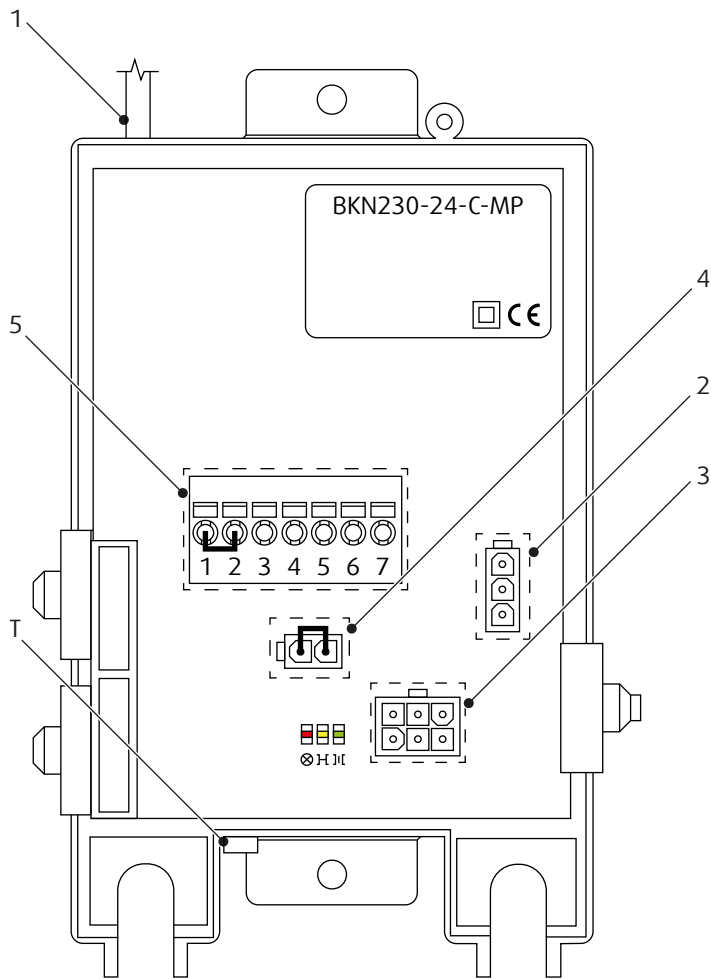

Legend

T - Button for test and address.

1 - Power supply: cable and plug, AC 230 V

2 - 3-pin connector: damper actuator (DC 24 V)

3 - 6-pin connector: damper actuator (position limit switches)

4 - 2-pin connector: BAT... thermoelectric tripping device

5 - Connecting terminals:

- 1 External smoke detector, +24 V, max. 50 mA
- 2 External smoke detector, control input
- 3 BKN slave
- 4 GND
- 5 MP-Bus
- 6 a BKS
- 7 b BKS

Type of activation BST10

IMPORTANT: Danger of electric shock! The BKN230-24-PL may only be used with a designated master (e.g. BKS64-PL).

Switch off the power supply before working on any electrical equipment.

Allow only qualified electricians to work on the electrical system.

Actuator power supply via fitted communication unit: DC 24 V

NOTES:

- Left: Connection scheme for fitted communication and supply unit BKN230-24-PL (Powerline)
- Right: Example connection scheme for smoke detector ORS 142 K from Hekatron - not part of the delivery.

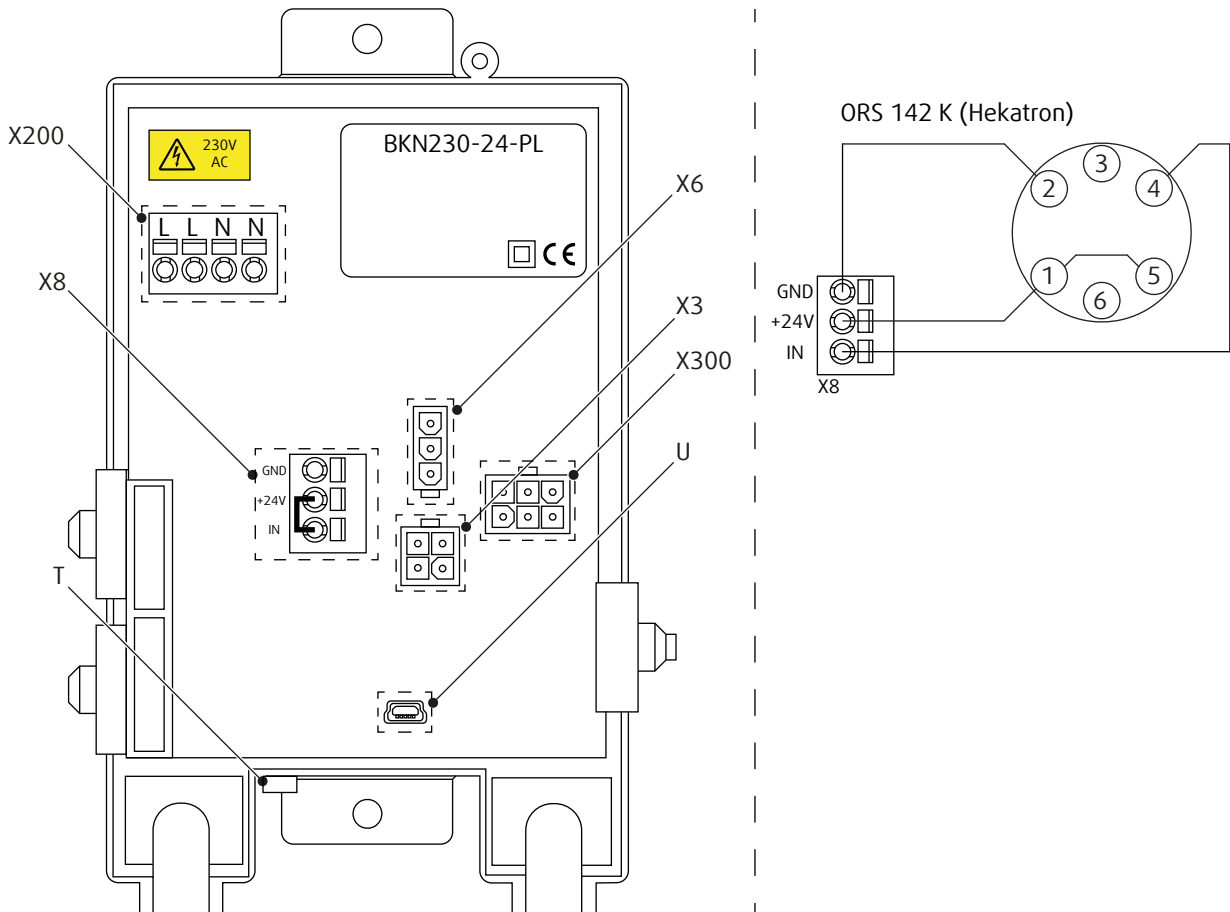

Legend

U - USB mini socket: reading of the MAC address, optionally setting the BUS-ID (1..64) and a device identifier in plain text

T - Test button: Test run / fault erase. Press the button for longer than one second to trigger the start of test run or short press to erase stored error

X6 and X300 connector terminals are arranged so that only either a conventional actuator or a Belimo Top-Line actuator can be connected.

X200 - 2+2-pin spring terminal: (50/60Hz) AC 230 V with Powerline signal.

X3 - 3-pin connector: damper actuator (DC 24 V).

X4 - 4-pin spring terminal: connection for smoke detector.

X6 - 6-pin connector: damper actuator (position limit switches).

X8 - 3-pin spring terminal: connection for smoke detector (without smoke detector: connect +24 V and IN).

- 1- GND.
- 2- (+) DC 24 V.
- 3- IN.

X300 - 4-pin connector: connection for belimo top-line actuator (not used).

Type of activation B24T-SR

IMPORTANT: Danger of electric shock!

Switch off the power supply before working on any electrical equipment.

Allow only qualified electricians to work on the electrical system.

Actuator power supply: AC (50/60 Hz)/DC 24 V

NOTES:

- Supply via safety isolation transformer.
- Power consumption must be monitored!

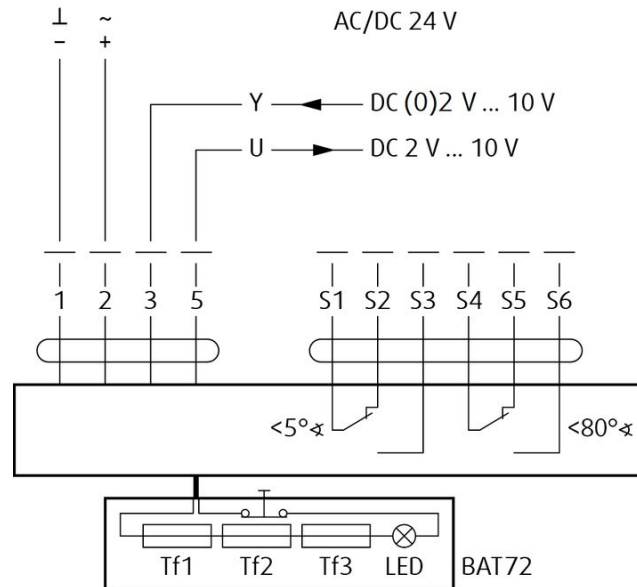

Legend

- 1** Blue cable colour
- 2** Brown cable colour
- 3** White cable colour
- 5** Orange cable colour
- S1** Violet cable colour
- S2** Red cable colour
- S3** White cable colour
- S4** Orange cable colour
- S5** Pink cable colour
- S6** Grey cable colour
- Tf** Thermal fuse

Type of activation G24T-SR

IMPORTANT: Danger of electric shock!

Switch off the power supply before working on any electrical equipment.

Allow only qualified electricians to work on the electrical system.

Actuator power supply: AC (50/60 Hz)/DC 24 V

NOTES:

- Supply via safety isolation transformer.
- Power consumption must be monitored!

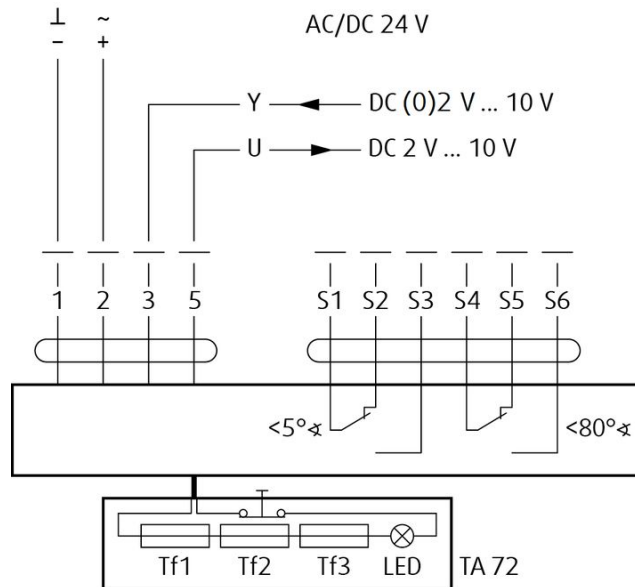

Legend

- 1** Blue cable colour
- 2** Brown cable colour
- 3** Black cable colour
- 4** Grey cable colour
- S1** Violet cable colour
- S2** Red cable colour
- S3** White cable colour
- S4** Orange cable colour
- S5** Pink cable colour
- S6** Grey cable colour
- Tf** Thermal fuse

Operation Manual

Warning

To avoid injury, make sure to wear gloves and keep the blades movement area clear while manipulating with the damper.

Fire Damper Functionality Check

Manually Operated Activation Mechanism

1. Open the damper - turn the red crank (P10) using an Allen bent wrench No. 10 (P13). Turn the red crank so that the indicator arrow is pointing to the "OPEN" position (P11), the red crank needs to remain in the "OPEN" position, and the microswitch for the open position indication must be pushed (if installed).
2. Close the damper - release the mechanism by pressing the red release button (P9), the red crank will adjust its indicator arrow pointing to the "CLOSED" position (P12) and remain locked in this position, the microswitch for the closed position indication must be pushed (if installed).
3. Open the damper - turn the red crank (P10) using an Allen bent wrench No. 10. (P13) Turn the red crank so that the indicator arrow is pointing to the "OPEN" position, the red crank needs to remain in the "OPEN" position, and the microswitch for the open position indication must be pushed (if installed).

Spring Return Actuator Operated Activation Mechanism

1. The fire damper must open automatically after the actuator circuit closes - the arrow on the actuator axis must show the position 90°.
2. Press the control switch (P9) on the Thermoelectric fuse and hold it until the fire damper is fully closed - the arrow on the actuator axis must show the position 0°.
3. Release the control switch on the Thermoelectric fuse. The fire damper must become fully open - the arrow on the actuator axis must show the position 90° - which is the operating position.

Smoke detector and spring return actuator operated activation mechanism

1. The fire damper must open automatically after the actuator circuit closes - the arrow on the actuator axis must show the position 90°.
2. Press the control switch (P9) on the Thermoelectric fuse and hold it until the fire damper is fully closed - the arrow on the actuator axis must show the position 0°.
3. Release the control switch (P9) on the Thermoelectric fuse. The fire damper must now open automatically.
4. Press the control switch on the smoke sensor and hold it until the fire damper is fully closed. Or use a smoke spray for sensor testing and spray into the grille directly onto the smoke detector. Check if the fire damper will fully close. After a while the smoke detector will clear itself from the testing spray and the damper will open again.
5. Release the control switch on the Thermoelectric fuse. The fire damper must become fully open - the arrow on the actuator axis must show the position 90° - which is the operating position.

Operation Manual

After installation, it is necessary to adjust the damper into its operating position - open the fire damper.

Spring Return Actuator Operated Activation Mechanism

Connect the electric driving mechanism to the relevant electric power supply (see Electrical connection section). The electromotor is activated and adjusts the damper into its open position.

Manually Operated Activation Mechanism

Turn the red crank into the "OPEN" position. The damper blade must remain in open position.

Damper Inspection

The activation mechanism keeps the dampers on stand-by during their entire life cycle in accordance with this manual issued by the manufacturer. It is not permitted to alter the dampers in any way nor perform any changes to their structure without the manufacturer's consent. The operator performs regular checks of the dampers as per established regulations and standards at least once every 12 months. The check needs to be performed by an employee who has been specifically trained for this purpose. The current fire damper condition determined during the inspection needs to be entered into the operating logbook along with the date of the inspection, the legible name, surname and signature of the employee who performed the inspection. The Operating Journal includes a copy of the employee's authorization. If any discrepancies are discovered, these need to be entered in the Operating Journal along with a proposal for their removal. The Operating Journal can be found in product documents section. Immediately after the installation and activation of the damper, it needs to be checked under the identical conditions as apply to the above mentioned 12-month inspections. The visual check ensures that visible damages on the inspected damper parts are seen. On its external side, the damper housing and the activation mechanism are checked. Due to the need to perform a visual check of the damper's internal parts, open the inspection lid. For small sizes there is the possibility of removing the mechanism to perform the inspection. The removable mechanism always needs to be returned back into the damper with the damper blade being closed. The damper's internal casing, thermal fuse, sealings, foaming substance, the damper blade condition, and accuracy of its closure during its leaning against the backstop in the closed position must all be checked. There must not be any strange objects or a layer of impurities from the air distribution systems inside the damper.

Recommended Inspection Steps According to the EN 15 650:

1. Damper identification
2. Date of inspection
3. Inspecting electric connection of the activation mechanism (where applicable)
4. Inspecting damper for cleanliness and possible need for cleaning (where needed)
5. Inspecting blade and sealing condition, possible correction and logging (where needed)
6. Inspecting proper fire damper closure
7. Inspecting damper functionality – opening and closing using the control system, physical examination of the damper's behavior, possible correction and logging (where needed)
8. Inspecting end switches' functionality in the open and closed position, possible correction and logging (where needed)
9. Inspect whether the damper is fulfilling its role as part of the regulation system (where needed)
10. Inspect whether the damper remains in its standard operating position.
11. The damper is usually part of a system. In that case the whole system needs to be checked as described in its operation and requirements published by the builder of the system.

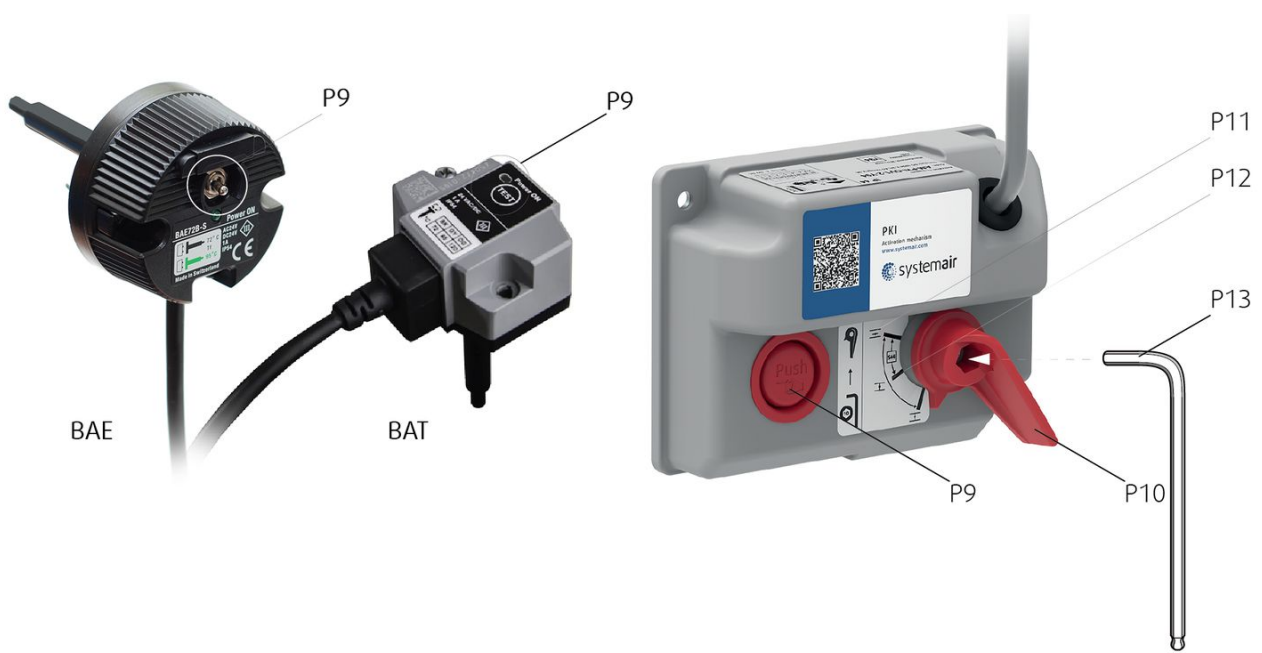

Supplement

Any deviations from the technical specifications contained in SystemairDESIGN and the terms should be discussed with the manufacturer. We reserve the right to make any changes to the product without prior notice, provided that these changes do not affect the quality of the product and the required parameters.

