

CAP-G

Multi-Nozzle Diffuser

Data Sheet



Table of Contents

Description	3
Design	4
Product Parts	4
Setup Possibilities	5
Dimensions	6
Ordering Code	7
Accessory	8
Quick Selection	10
Technical Parameters	10
Installation, Maintenance & Operation	16
Transport & Storage	16
Supplement	16
Related Products.	17



Good to know

Current information on all products is available at www.design.systemair.com



Description

CAP-G is a multi-nozzle diffuser with a backing box, mainly intended for air supply in comfort ventilation systems for offices, shops, medical rooms, school classrooms, etc., installed in plaster board false ceiling.

Highlights

- Versatile adjustability of air discharge patterns
- Excellent air induction and mixing even with small air flow volumes, fit for VAV ventilation
- High air flow capacity with low noise and moderate pressure drop
- Compact design

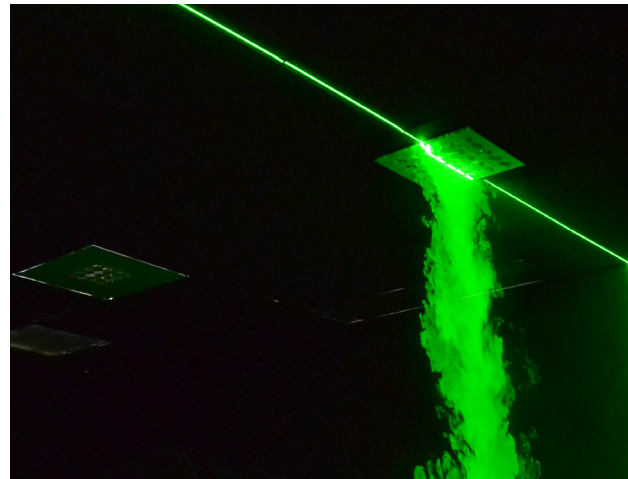
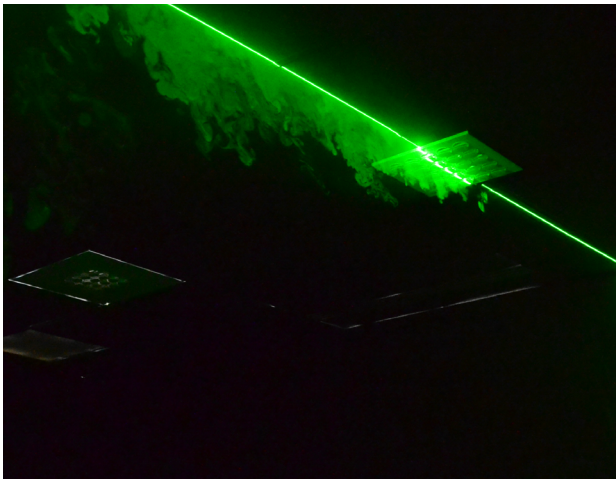

Fig. 1: Air flow visualisation

Design

The CAP-G body is made from galvanized steel, composed of the backing box with a vertically oriented rubber gasket sealed circular connection and diffuser plate with polymer nozzles, attached by spring clips.

The nozzles can be rotated by 360° in the plane of the diffuser plate. The proper directional adjustment of the individual nozzles results in the desired air discharge pattern. For the installation of the diffuser, there are holes in the backing frame for screws to fix in the false ceiling board

Product Parts

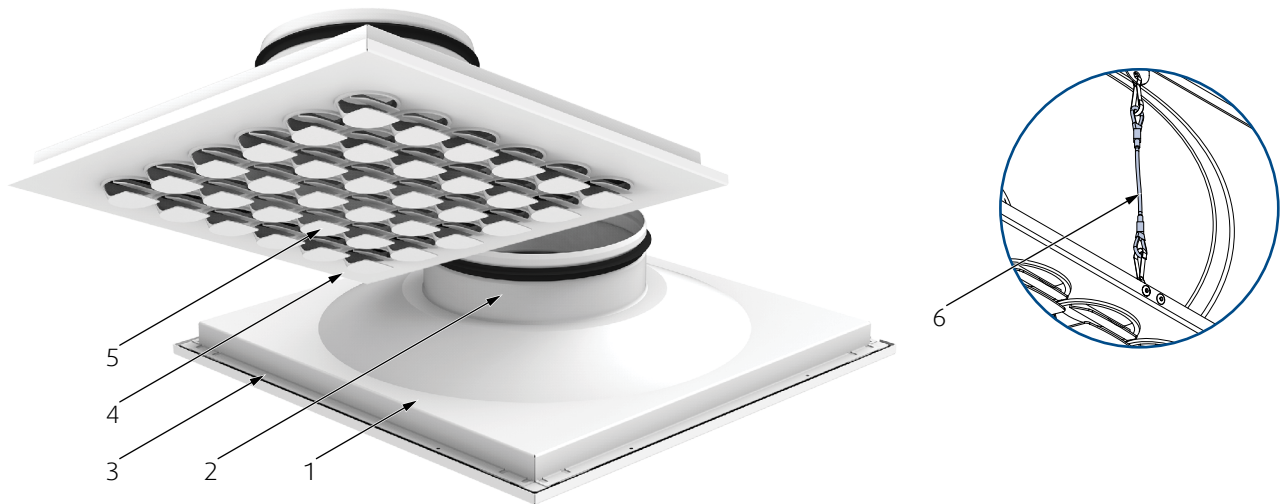

Fig. 2: Components of CAP-G

Legend

1	Backing box
2	Connection with rubber gasket
3	Spring clips for diffuser plate fixing (inside the backing box)
4	Diffuser plate
5	Nozzles
6	Safety cable (inside the backing box)

Setup Possibilities

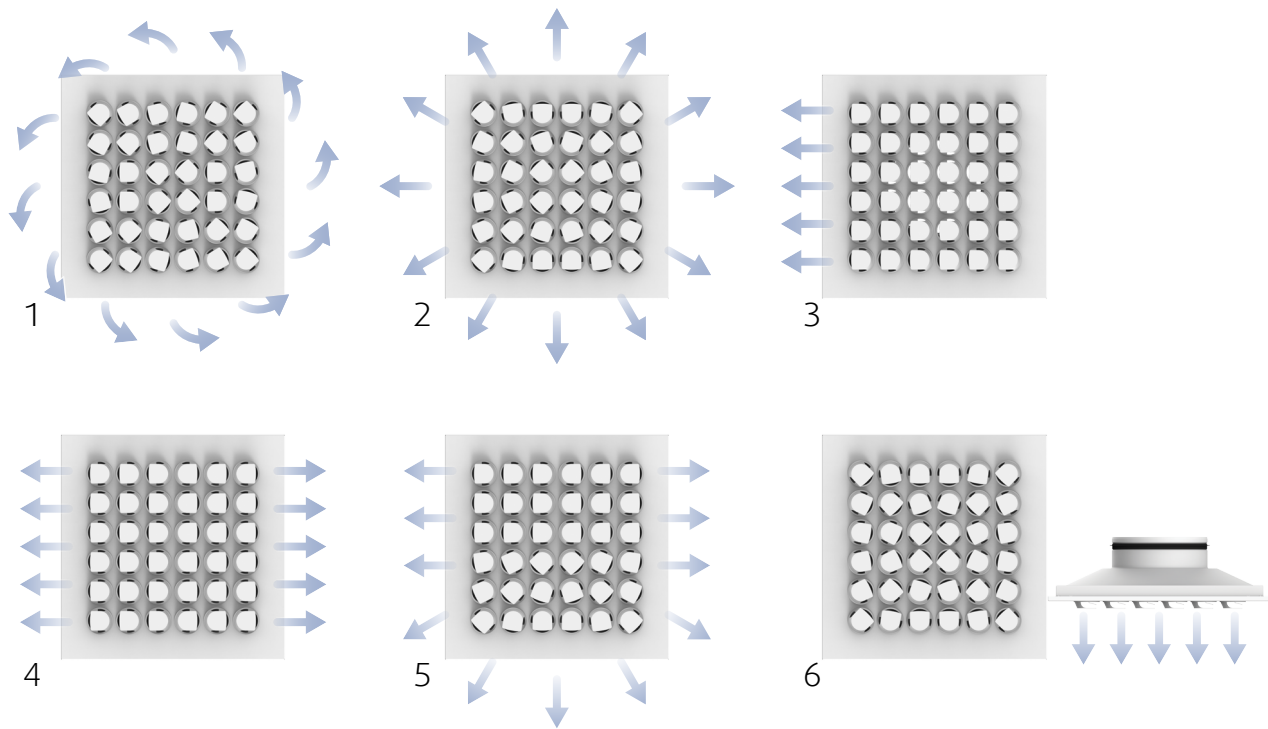

Fig. 3: Nozzle adjustments and resulting air flow pattern

Legend

1	Tangential horizontal swirl discharge
2	Radial horizontal omnidirectional discharge
3	Horizontal discharge, single direction
4	Horizontal discharge, 2 directions
5	Horizontal discharge, 3 directions
6	Vertical discharge

Dimensions

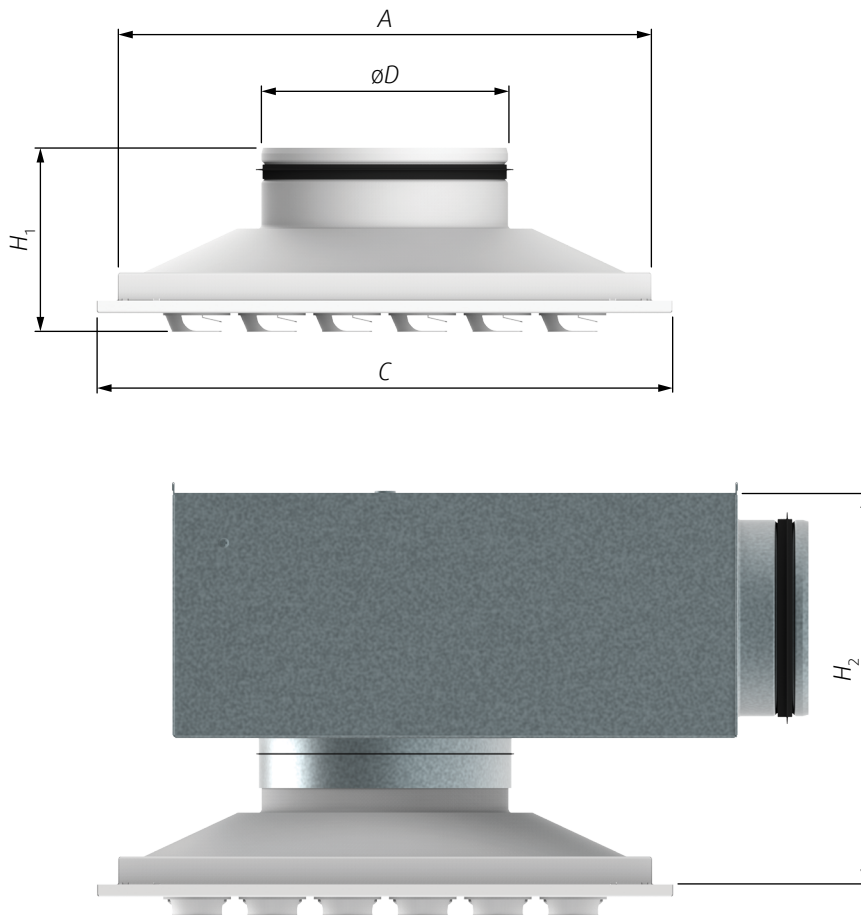

Fig. 4: Dimensions of the CAP-G

Tab. 1: Dimensions of the CAP-G

Name	A	C	H_1	H_2	$\varnothing D$	m
	(mm)					(kg)
CAP-G-125-16*	326	360	119	248	124	2,0
CAP-G-160-25*	326	360	122	261	159	2,1
CAP-G-200-36*	426	460	122	296	199	3,3
CAP-G-250-49*	566	600	122	351	249	5,0
CAP-G-315-81*	566	600	119	398	314	5,0

NOTE: * Number of nozzles

Ordering Code

		CAP-G-		-	
		125-16			
		160-25			
		200-36			
		250-49			
Nominal size (con. diameter) - Number of nozzles		315-81			
	(RAL9010)	W			
	(RAL9003)	SW			
Surface and nozzle colour		RALXXXX			

Example of the Ordering Code

CAP-G-250-49-W

Diffuser CAP-G in white colour (RAL 9010) with connection diameter 250 mm and 49 nozzles.

Accessory

THOR

Plenum Box

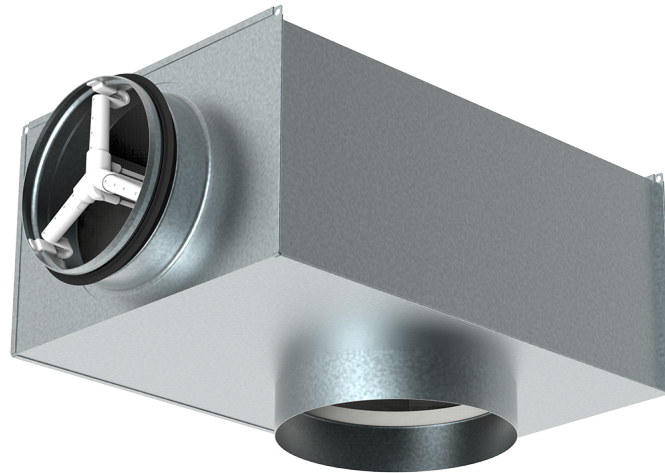

Description

The THOR plenum box is used together with air diffusers for pressure reduction, airflow balancing and sound attenuation as well as for measuring and adjusting the air flow. The standard air flow measurement accuracy is preserved also when the straight duct length in front of the inlet is zero (directly behind Tee or Elbow piece in the duct). The plenum box can be used for air inlet and extract.

Design

THOR plenum boxes are manufactured from hot-dip galvanized sheet steel with inlet connection sleeve fitted with a rubber seal tested for air-tightness. The inlet is equipped by the ZEUS damper with impulse tubes for measuring differential pressure for flow volume calculation, using a portable measuring device. It can be adjusted manually using a cable gearing.

Dimensions

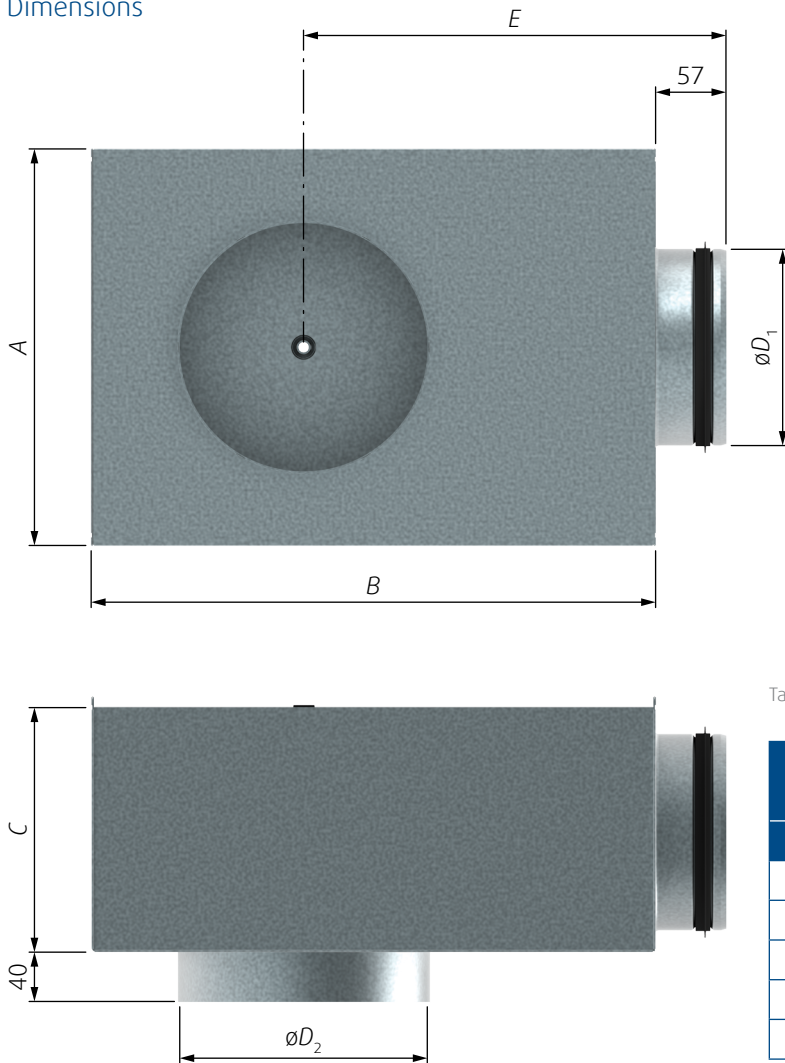

Tab. 2: Dimensions of the THOR

Type DN ₁ - DN ₂	A	B	C	øD ₁	øD ₂	E	m
(mm)							(kg)
100-125	250	300	150	99	126	185	2,5
125-160	250	340	160	124	161	210	2,7
160-200	300	430	195	159	202	280	4,0
200-250	350	480	250	199	252	305	5,9
250-315	450	545	300	249	317	330	8,3

Fig. 5: Dimensions of the THOR

Ordering Code

		THOR-	<input type="text"/>	-	<input type="text"/>
			100		
			125		
			160		
			200		
Inlet	DN ₁ (mm)		250		
			125		
			160		
			200		
			250		
Outlet	DN ₂ (mm)		315		

Example of the Ordering Code

THOR-125-160

Plenum box THOR with 125 mm circular inlet and 160 mm circular outlet (nominal dimensions).

Quick Selection

Type	Air flow volume q and pressure drop ΔP at different sound power levels L_{WA}					
	25 dB		30 dB		35 dB	
	m ³ /h	l/s	m ³ /h	l/s	m ³ /h	l/s
CAP-G-125-16	81	23	109	30	137	38
CAP-G-160-25	97	27	132	37	178	49
CAP-G-200-36	131	36	180	50	239	66
CAP-G-250-49	161	45	243	68	318	88
CAP-G-315-81	225	63	342	95	483	134

NOTE: The working points were measured with THOR plenum box and open adjustment damper.

Technical Parameters

Legend

p_s	Pa	Pressure drop
q_v	m ³ /h l/s	Air flow volume
L_{WA}	dB(A)	A-weighted total radiated sound power level
L_{pA}	dB(A)	A-weighted total sound pressure level expressed for 10 m ² room absorption area
L_w	dB	Non weighted total sound power level
$L_{0,2}$	m	Air throw length with terminal velocity 0,2 m/s
L_x	m	Air throw length calculated for specific terminal velocity
x	m/s	Terminal velocity in range of 0,1 m/s ... 1 m/s
20%, 40%, 60%, 80%, 100%		The plenum box damper positions in pressure drop/noise diagrams are represented as percentage. 20% is fully closed damper. 100% is fully open damper.

Calculation of Air Throw for Different Terminal Velocities

$$L_x = L_{0,2} \cdot 0,2/x$$

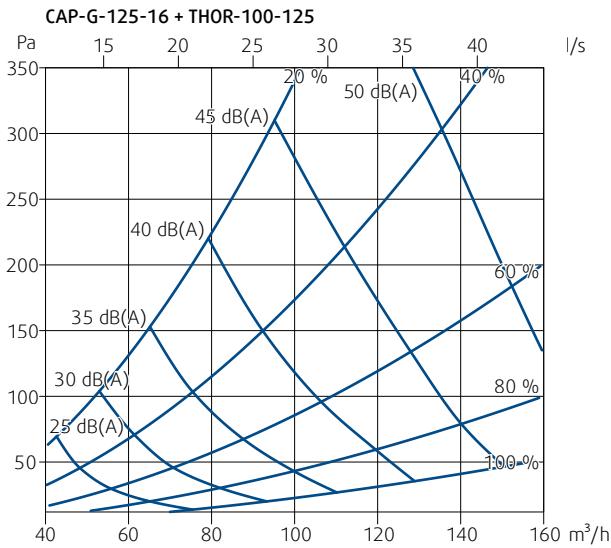

Diagram 1: Pressure drop & A-weighted total sound power level, depending on air flow volume, measured with THOR plenum box

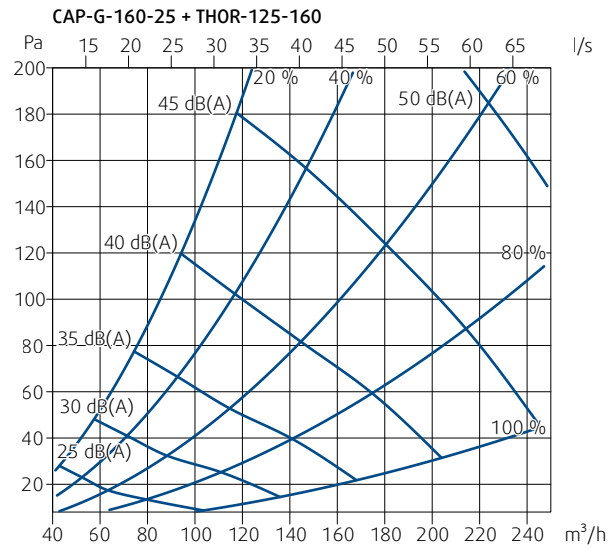

Diagram 3: Pressure drop & A-weighted total sound power level, depending on air flow volume, measured with THOR plenum box

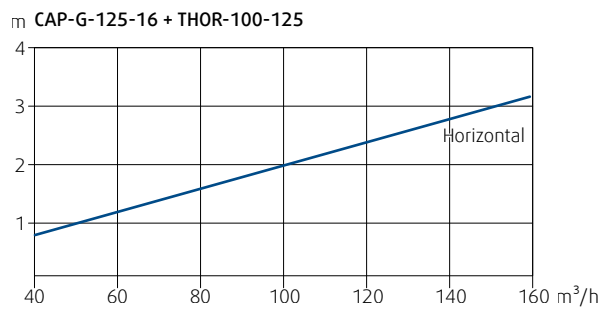

Diagram 2: Isothermal air throw lengths for horizontal radial discharge with terminal velocity 0,2 m/s, depending on air flow volume

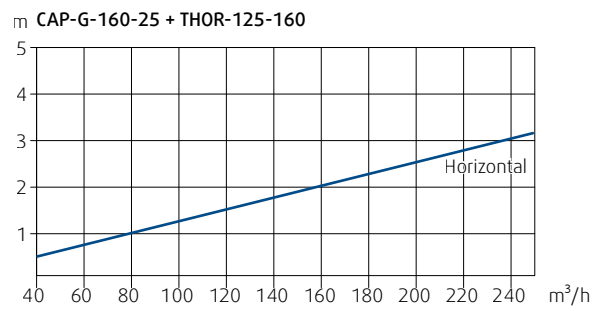

Diagram 4: Isothermal air throw lengths for horizontal radial discharge with terminal velocity 0,2 m/s, depending on air flow volume

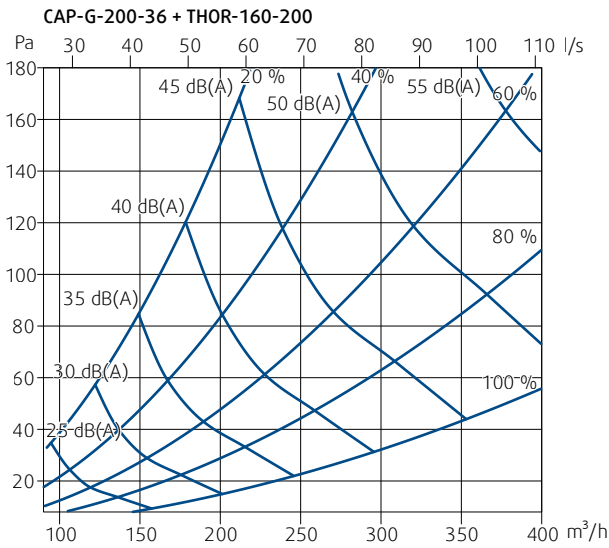

Diagram 5: Pressure drop & A-weighted total sound power level, depending on air flow volume, measured with THOR plenum box

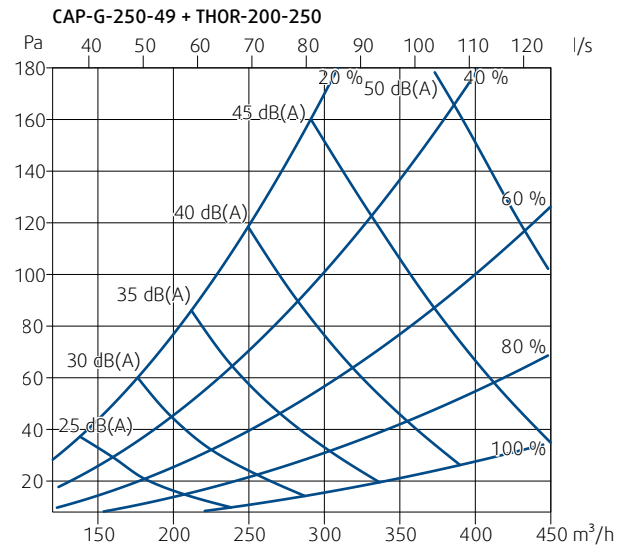

Diagram 7: Pressure drop & A-weighted total sound power level, depending on air flow volume, measured with THOR plenum box

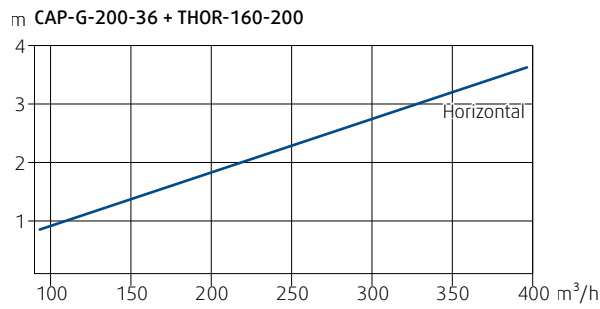

Diagram 6: Isothermal air throw lengths for horizontal radial discharge with terminal velocity 0,2 m/s, depending on air flow volume

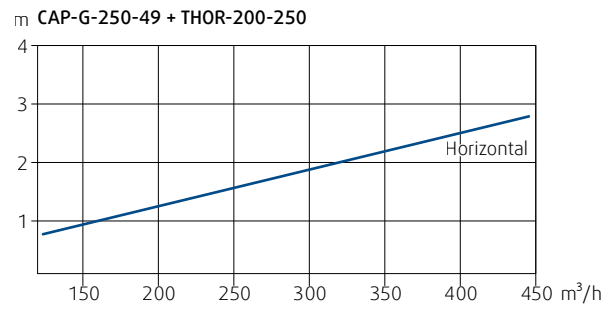

Diagram 8: Isothermal air throw lengths for horizontal radial discharge with terminal velocity 0,2 m/s, depending on air flow volume

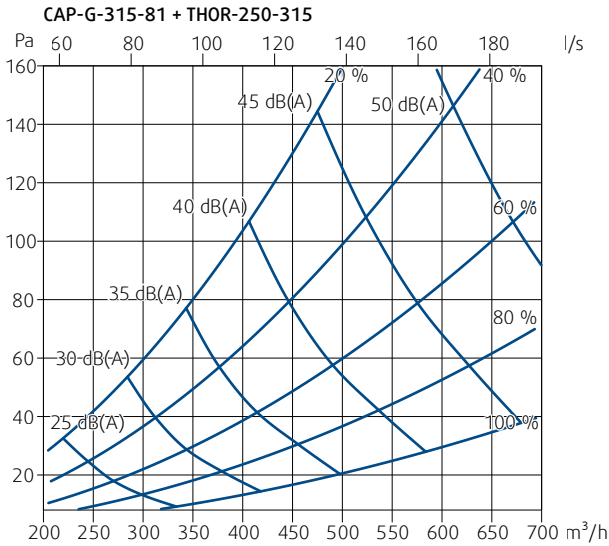

Diagram 9: Pressure drop & A-weighted total sound power level, depending on air flow volume, measured with THOR plenum box

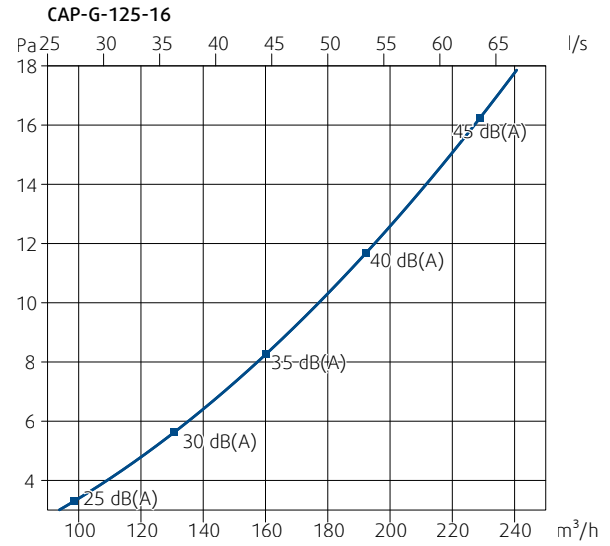

Diagram 11: Pressure drop & A-weighted total sound power level, depending on air flow volume, measured without plenum box

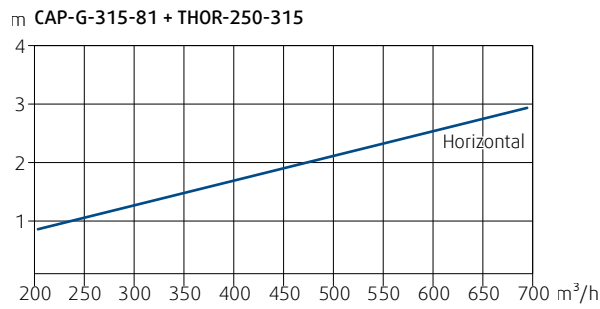

Diagram 10: Isothermal air throw lengths for horizontal radial discharge with terminal velocity 0,2 m/s, depending on air flow volume

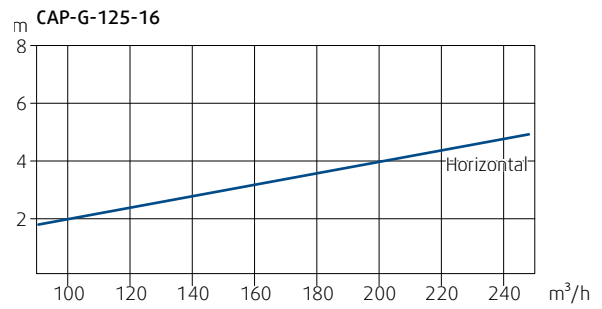

Diagram 12: Isothermal air throw lengths for horizontal radial discharge with terminal velocity 0,2 m/s, depending on air flow volume

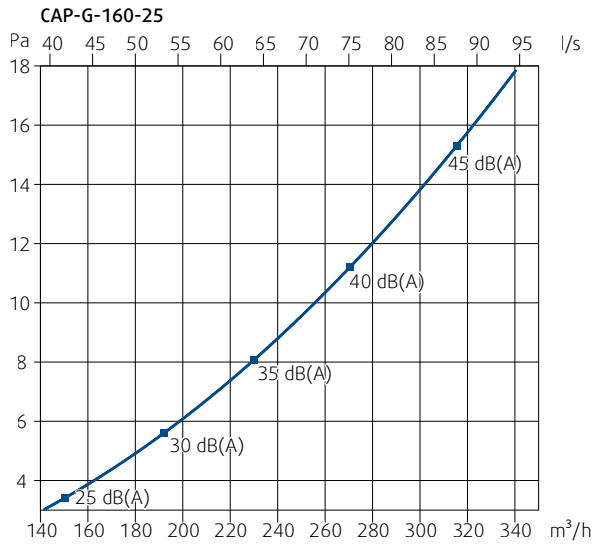

Diagram 13: Pressure drop & A-weighted total sound power level, depending on air flow volume, measured without plenum box

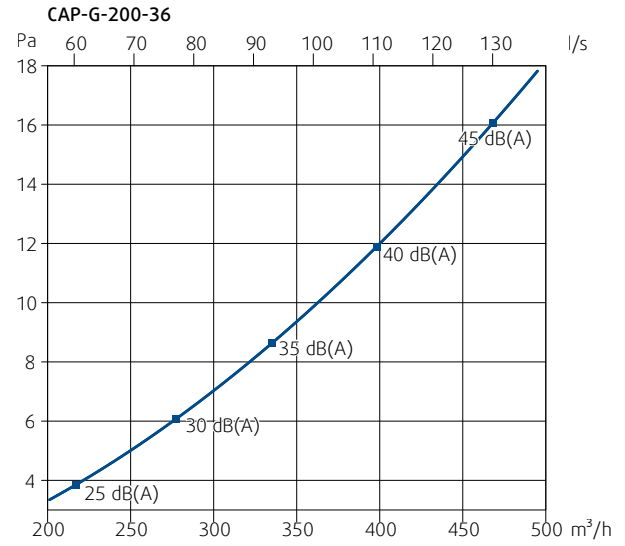

Diagram 15: Pressure drop & A-weighted total sound power level, depending on air flow volume, measured without plenum box

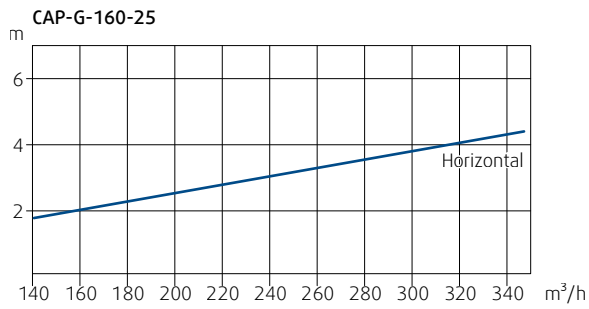

Diagram 14: Isothermal air throw lengths for horizontal radial discharge with terminal velocity 0,2 m/s, depending on air flow volume

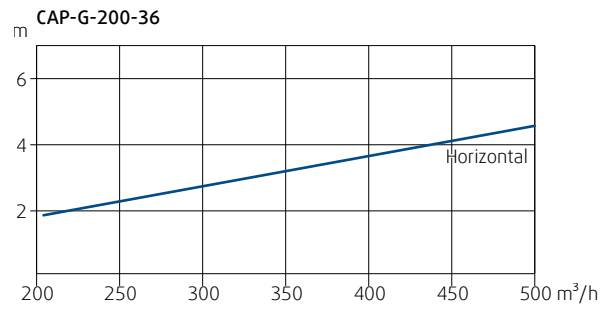

Diagram 16: Isothermal air throw lengths for horizontal radial discharge with terminal velocity 0,2 m/s, depending on air flow volume

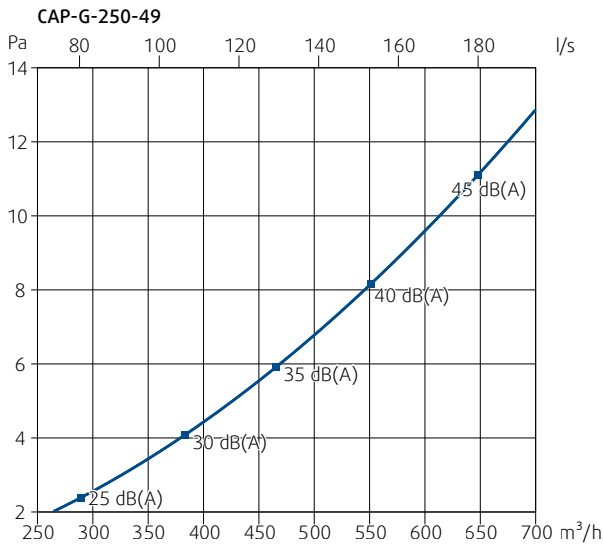

Diagram 17: Pressure drop & A-weighted total sound power level, depending on air flow volume, measured without plenum box

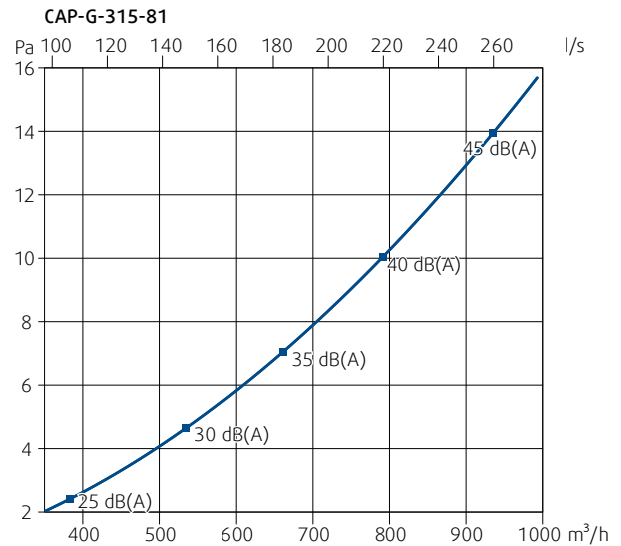

Diagram 19: Pressure drop & A-weighted total sound power level, depending on air flow volume, measured without plenum box

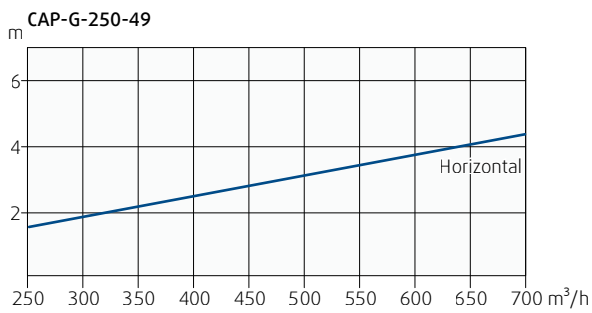

Diagram 18: Isothermal air throw lengths for horizontal radial discharge with terminal velocity 0,2 m/s, depending on air flow volume

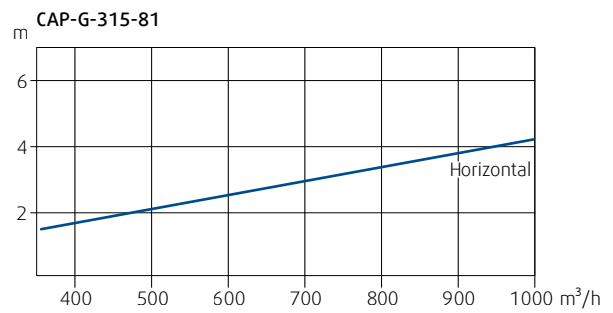

Diagram 20: Isothermal air throw lengths for horizontal radial discharge with terminal velocity 0,2 m/s, depending on air flow volume

Installation, Maintenance & Operation

Information about installation, maintenance and operation is available in the document ["DataSheet_CAP-G"](#) or follow the instructions at [Systemair DESIGN](#).

Operate in dry indoor conditions with an operation temperature range of -20 °C to +50 °C.

Transport & Storage

Dry indoor conditions with a temperature range of -40°C to +50°C.

Supplement

Any deviations from the technical specifications contained herein and the terms should be discussed with the manufacturer. We reserve the right to make any changes to the product without prior notice, provided that these changes do not affect the quality of the product and the required parameters.

Current information on all products is available at [Systemair DESIGN](#).

Related Products

CAP-F

Multi-Nozzle Diffuser

Product information is available within the ["UserManual_CAP-F"](#) technical documentation and at [Systemair DESIGN](#).



